

**DEPARTMENT OF FORESTRY, FISHERIES AND THE ENVIRONMENT**

**NO. 2598**

**7 October 2022**

**METHODOLOGICAL GUIDELINES FOR QUANTIFICATION OF GREENHOUSE GAS EMISSIONS**

I, Barbara Dallas Creecy, Minister of Forestry, Fisheries and the Environment, hereby, in terms of section 12 of the National Environmental Management: Air Quality Act, 2004 (Act No. 39 of 2004), read with regulation 10 of the National Greenhouse Gas Emission Reporting Regulations, published under Government Notice No. 275 in the Government Gazette 40762 of 3 April 2017, publish the Methodological Guidelines for Quantification of Greenhouse Gas Emissions, as set out in the Schedule hereto.



**BARBARA DALLAS CREECY  
MINISTER OF FORESTRY, FISHERIES AND THE ENVIRONMENT**

---

**SCHEDULE**

0

# METHODOLOGICAL GUIDELINES FOR QUANTIFICATION OF GREENHOUSE GAS EMISSIONS

A companion to the South African National GHG Emission Reporting Regulations

Version No: MG-2022.1

Release Date: August 2022

Please note: This guideline must be read together with the National Environmental Management: Air Quality Act (39/2004): National Greenhouse Gas Emission Reporting Regulations, 2016, Gazette number: 40762 and its subsequent amendments.

All technical enquiries and should be addressed to –

Department of Forestry, Fisheries and the Environment  
Climate Change Monitoring, Evaluation and Mitigation  
Private Bag X447 Pretoria 0001, South Africa.  
Email: [ghgreporting@dfpe.gov.za](mailto:ghgreporting@dfpe.gov.za)

**Technical Contributors/ Authors**

Jongikhaya Witi  
Phindile Mangwana  
Farryn Sherman  
Sewela Malaka  
Mamahloko Senatla Jaane  
Rumbidzai Zireva  
Hendrik Louw  
Sindisiwe Mashele

## TABLE OF CONTENTS

TABLE OF CONTENTS.....	i
LIST OF FIGURES.....	vii
1. Introduction .....	1
2. Overview.....	2
3. Commonalities and Differences between the IPCC Guidelines and the Corporate Standard 6	
4. Structure of this Methodological Guideline .....	12
5. Reporting.....	13
6. Setting of reporting boundaries.....	19
7. Methodology .....	20
8. Time frames.....	24
9. Activity data.....	25
10. Emission Factors .....	29
11. Quality Assurance/Quality Control and Verification requirements.....	36
Methodological guidance .....	37
12. Stationary Combustion .....	38
13. Public Electricity Generation.....	43
14. Combined Heat and Power.....	45
15. Charcoal Production .....	47
16. Biochar Production .....	49
17. Coke Production.....	51
18. The Oil and Gas Sector (Includes Petroleum Refining).....	53
19. Coal-to-liquids and Gas-to-Liquids/Chemicals Processes .....	58
20. Aviation Industry.....	61
21. Water-borne Navigation (1.A.3.d).....	65
22. Railways.....	67
23. Coal Mining.....	69
24. Mining and Quarrying.....	74
25. Carbon Capture and Storage.....	76
26. Cement Production .....	78
27. Lime Production.....	81
28. Glass Production .....	84
29. Other Process Uses of Carbonates .....	88
30. Ammonia Production .....	94
31. Nitric Acid Production .....	99

32.	Carbide Production .....	103
33.	Titanium Dioxide Production.....	107
34.	Soda Ash Production .....	110
35.	Petrochemical and Carbon Black Production .....	113
36.	Hydrogen production.....	117
37.	Iron and Steel Production .....	126
38.	Ferroalloys and Other Metals Production .....	138
39.	Aluminium Production.....	144
40.	Magnesium Production.....	148
41.	Lead Production .....	152
42.	Zinc Production.....	155
43.	Other .....	157
44.	Other Product and Manufacture Use .....	159
45.	Pulp and Paper Industry.....	166
46.	Solid Waste Disposal (industrial sites).....	168
47.	Industrial Wastewater Treatment.....	171
48.	Domestic Wastewater Treatment.....	177
49.	Waste Incineration.....	184
50.	Poultry (Installations for the intensive rearing of poultry).....	188
51.	Forestland Remaining Forestland .....	196
52.	Land Converted to Forest Land.....	198
53.	Biomass Burning in Forest Lands.....	199
54.	Direct N <sub>2</sub> O Emissions from Managed Soils.....	200
55.	Indirect N <sub>2</sub> O Emissions from Managed Soils.....	201
56.	Harvested Wood Products (HWP).....	202
	References .....	203
	ANNEXURES.....	205
	Annexure A: Stationary Combustion – Emission factors.....	206
	Annexure B: Fugitive Emissions – Emission Factors .....	210
	Annexure C: Default IPCC Emission Factors for Industrial Processes and Product Use .....	214
	Annexure D: Country-specific Net Caloric Values of fuels .....	221
	Annexure E: Basic information on Units.....	222
	Annexure F: IPCC Source Codes and Definitions (GHG Activities listed in Annexure 1 of the National Greenhouse Gas Emissions Reporting Regulations (DEA 2016).....	223
	Annexure G: Global Warming Potential Values. IPCC Third Assessment Report, 2001 (IPCC 2001, Ch6, 388) .....	245
57.	Annexure H: Default factors to estimate poultry manure management emissions.....	248

## LIST OF TABLES

Table 3:1: Summary of key IPCC reporting requirements and implications for companies and government.....	8
Table 3:2: NCV types and corresponding activity units.....	11
Table 5:1: Reporting subsector/activities.....	13
Table 5:2: IPCC source categories and their associated Thresholds (NGERs, 2016).....	14
Table 7:1: Standard measurement methods for exhaust gases (IPCC 2006, Vol 1, 2.16).....	22
Table 8:1: Important timelines that need to be considered when reporting under the Regulation...	24
Table 9:1: IPCC Source codes stipulated in NGERs Annexure 1 and their associated activity data needs for a tier1/2 IPCC methodology.....	25
Table 10:1: Template to be used by data providers for the process of adopting a new emission factor (DEA 2016, 22).....	29
Table 12:1 IPCC sectors covered by stationary combustion.....	40
Table 13:1: IPCC emission sources for Electricity Generation.....	43
Table 14:1: IPCC classification of emissions for combined heat and power.....	45
Table 15:1 IPCC emission sources associated with Charcoal Production.....	47
Table 15:2: Emission factors for fugitive CH <sub>4</sub> emissions from charcoal production as detailed in Volume 3, Energy, Table 1-14 from the 1996 IPCC Guidelines (IPCC 1996, 1.46).....	48
Table 15:3: Emission factors for fugitive emissions from charcoal production as detailed in Volume 2, Energy, Table 4.3.3 from the 2019 IPCC Refinements (IPCC 2019).....	48
Table 16:1: IPCC emission sources associated with Biochar Production.....	49
Table 16:2: Emission factors for fugitive emissions from biochar production as detailed in Volume 2, Energy, Table 4.3.3 from the 2019 IPCC Refinements (IPCC 2019).....	50
Table 17:1: IPCC emission sources associated with Coke Production.....	51
Table 17:2: Emission factors for fugitive CH <sub>4</sub> emissions from coke production as detailed in Volume 2, Energy, Table 4.3.5 from the 2019 IPCC Refinement (IPCC 2019).....	52
Table 18:1: IPCC classification of emissions for oil and gas sector.....	53
Table 19:1: IPCC classification of emissions for coal-to-liquids, gas-to liquids and gas-to-chemicals.....	58
Table 19:2: IPCC categories for fugitive emissions from natural gas.....	60
Table 20:1: IPCC classification of emissions for the aviation industry.....	61
Table 20:2: Guidelines on Tier 3 methodology for IPCC source categories: 1A3ai and 1A3aii.....	63
Table 20:3: Activity data requirements for domestic aviation.....	64
Table 21:1: IPCC sectoral breakdown covered by Water-borne Navigation.....	65
Table 21:2: IPCC Classification of emissions for Water-borne Navigation.....	65
Table 22:1: IPCC classification of emissions for railways.....	67
Table 22:2: Default emission factors for the most common fuels used for rail transport.....	68
Table 23:1: IPCC Classification of emissions for Mining of Fuels (coal mining).....	69
Table 24:1: IPCC classification of emissions for Mining and Quarrying.....	74
Table 25:1: IPCC Classification of emissions for Carbon Capture and Storage.....	76
Table 26:1: IPCC classification of emissions for cement production.....	78
Table 26:2: Cement emission data requirements.....	80
Table 27:1: IPCC classification of emissions for lime production.....	81
Table 27:2: Lime Production emission activity data.....	83
Table 28:1: IPCC classification of emissions for glass production.....	84
Table 28:2: Glass production emissions data requirements.....	86
Table 28:3: Default emission factors and cullet ratios for different types of glass.....	87
Table 29:1: IPCC classification of emissions for glass production.....	88

Table 29:2: Formulae, Formula Weights, and Carbon Dioxide Contents of Common Carbonate Species*.....	90
Table 29:3: Users of Limestone (CaCO <sub>3</sub> ), dolomite (CaMg(CO <sub>3</sub> ) <sub>2</sub> ) and other carbonates (e.g., MgCO <sub>3</sub> and FeCO <sub>3</sub> ) (including ceramics, soda ash users, non-metallurgical magnesia production, and others) .....	91
Table 29:4: Possible emissive Uses of Carbonates.....	92
Table 30:1: IPCC classification of emissions for Ammonia Production .....	94
Table 30:2: Choice of Activity data .....	96
Table 30:3: Default total fuel requirements (fuel plus feedstock) and emission factors for Ammonia production (per Tonne NH <sub>3</sub> ) .....	97
Table 31:1: IPCC classification of emissions for Nitric Acid Production .....	99
Table 31:2: Nitric acid production emissions data requirements.....	101
Table 31:3: Default factors for Nitric Acid production for IPCC tier 1 and 2 methodologies (IPCC 2006).....	102
Table 32:1: IPCC classification of emissions for silicon carbide production.....	103
Table 32:2: Carbide production emissions activity data (silicon and calcium carbide).....	105
Table 32:3: Default emission factors for silicon and carbide production (IPCC 2006) .....	106
Table 32:4: Default emission factors for CO <sub>2</sub> emission from Calcium Carbide production and use (IPCC 2006) .....	106
Table 33:1: IPCC classification of emissions for titanium dioxide production .....	107
Table 33:2: Titanium dioxide production emissions data requirements .....	108
Table 33:3: Default emission factors for titanium dioxide production (IPCC 2006).....	109
Table 34:1: IPCC classification of emissions for soda ash production.....	110
Table 34:2: Soda ash production emissions data requirements (natural soda ash).....	112
Table 35:1: IPCC classification of emissions from petrochemical and carbon black production. ..	113
Table 35:2: Petrochemical (methanol, ethylene, ethylene dichloride and chloride monomer, ethylene oxide, acrylonitrile) and Carbon black production emissions activity data .....	115
Table 35:3: Default emission factors for Carbon Black production (IPCC 2006) .....	116
Table 36:1: Current hydrogen production methods - status of development and allocation of emission factors .....	117
<b>Table 36:2: IPCC classification of emissions for hydrogen production .....</b>	<b>118</b>
Table 36:3: Hydrogen production activity data requirements .....	124
Table 36:4: Default carbon content factors for Hydrogen Production (2019 IPCC Refinements).124	
Table 37:1 IPCC Classification of Iron and Steel Production.....	126
Table 37:2: Example of data inputs for integrated iron and steel carbon balance .....	132
Table 37:3: Carbon content factors for the tier 2 methodology (IPCC 2006) .....	136
Table 38:1: Direct emissions for ferroalloy and other metal production linked to the IPCC Source Category for the GHG Reporting Regulations.....	138
Table 39:1: IPCC classification of aluminium production.....	144
<b>Table 39:2: Aluminium production emissions data requirements for CO<sub>2</sub>, CF<sub>4</sub> and C<sub>2</sub>F<sub>6</sub>..</b>	<b>147</b>
Table 40:1: IPCC classification of emissions for magnesium production.....	148
Table 40:2: Activity data requirements for Magnesium production .....	150
Table 41:1 IPCC Classification of emissions for lead production.....	152
Table 41:2: Tier 2 - Material-specific carbon content for lead production (IPCC 2006, Volume 3, Chapter 4, Table 4.22).....	153
Table 42:1 IPCC Classification of emissions for Zinc Production.....	155
Table 43:1 IPCC Classification of emissions for Other.....	157
Table 43:2: Activity data required for emission estimation.....	158

Table 44:1 IPCC Classification of emissions from SF <sub>6</sub> emissions.....	159
Table 44:2: SF <sub>6</sub> activity data.....	164
Table 44:3: Default emission factors for SF <sub>6</sub> lifecycle (IPCC, 2006).....	165
Table 45:1 IPCC classification of emissions for the pulp and paper industry.....	166
Table 46:1 IPCC classification for Solid Waste.....	168
Table 46:2: Type of Solid Waste Disposal Site and methane correction factors (MCF).....	170
Table 47:1: IPCC classification for industrial wastewater treatment.....	171
Table 47:2: Type of treatment and discharge pathway with corresponding methane correction factor (MCF).....	173
Table 47:3: Default Industrial Wastewater Data (Table 6.12, 2019 IPCC Refinement).....	174
Table 47:4: Wastewater treatment nitrogen removal fractions (N <sub>REM</sub> ) according to treatment type (Table 6.10c, 2019 IPCC Refinements).....	175
Table 47:5: Default IPCC activity data that could be used to quantify GHG emissions if plant-specific data is not available (Doorn et al, 1997).....	175
Table 47:6: Default N <sub>2</sub> O emission factor values for industrial wastewater (Table 6.8A, 2019 IPCC Refinement).....	176
Table 48:1: IPCC classification for domestic wastewater treatment.....	177
Table 48:2: Type of treatment system with corresponding methane correction factor (MCF) (Table 6.3, 2006 IPCC Guidelines).....	179
Table 48:3: Type of discharge pathway with corresponding methane correction factor (MCF) (Table 6.3, 2019 IPCC Refinements).....	180
Table 48:4: Wastewater treatment organics removal fractions (TOW <sub>REM</sub> ) according to treatment type (Table 6.6B, 2019 IPCC Refinements).....	181
Table 48:5: N <sub>2</sub> O Emission Factors for domestic wastewater (Table 6.11, 2006 IPCC Guidelines).....	183
Table 49:1: IPCC classification for Solid Waste.....	184
Table 49:2: Default data for CO <sub>2</sub> emission factors for incineration (based on table 5.2 IPCC 2006 Volume 5, Chapter 5).....	186
Table 49:3: CH <sub>4</sub> Emission factors for incineration of municipal solid waste (MSW).....	187
Table 50:1: IPCC classification for Poultry (Installations for the intensive rearing of poultry).....	188
Table 51:1: IPCC classification for Forestland Remaining Forestland.....	197
Table 52:1: IPCC classification for Land converted to Forest land.....	198
Table 53:1: IPCC classification for Biomass Burning in Forest Lands.....	199
Table 54:1: IPCC classification for Direct N <sub>2</sub> O Emissions from Managed Soils.....	200
Table 55:1: IPCC classification for Indirect N <sub>2</sub> O Emissions from Managed Soils.....	201
Table 56:1: IPCC classification for Harvested Wood Products.....	202
Table A.1: Default Emission Factors and Net Calorific Values for Stationary Combustion – (solid, liquid and gaseous fuels).....	206
Table A.2: Default emission factors and net calorific values for mobile combustion.....	208
Table A.3: Country specific CO <sub>2</sub> emission factors for stationary and mobile combustion: from the 2022 Liquid & Gas Fuel Study and 2022 Cement Study).....	208
Table B.1: Country specific emission factors for fugitive emissions from coal mining (Lloyd and Cook, 2005).....	210
Table B.2: Default emission factors for fugitive emissions from coal mining, oil and gas operations (IPCC 2006).....	210
Table B.3: Default emission factors for fugitive emissions from coal mining, oil and gas operations (IPCC 2019 Refinements).....	213
Table C.1: Default IPCC emissions factors for Industrial Process and Product Use (IPCC 2006).....	214



Table D.1: Net calorific values for liquid, gaseous and solid fuels (provided by the South African Petroleum Industry Association and from the 2022 Liquid & Gas Fuel Study and 2022 Cement Study) .....	221
Table F.1: IPCC source codes and definitions .....	223

## LIST OF FIGURES

Figure 3:1: A step-by-step approach to reporting corporate emissions in the SAGERS Portal.....	10
Figure 6:1: Diagram depicting operational control.....	19
Figure 7:1: Tiers as per the 2006 IPCC Guidelines.....	21
Figure 11:1: Process flow summary of the NGERs Verification Programme.....	36
Figure 12:1: Annexure 5: Registration of Standby Generators.....	39
Figure 13:1 : Process flow for Electricity Generation.....	44
Figure 14:1: Process flow for Combined Heat and Power generation (CHP).....	46
Figure 15:1: Process flow for Charcoal Production.....	48
Figure 23:1: Process flow for Mining of Fuels (coal mining).....	70
Figure 29:1: Example of chemical analysis to be undertaken.....	90
Figure 36:1: Steam reforming process flow.....	118
Figure 37:1: Process emissions flow for iron and steel (Including IPCC codes 1A2a, 2C1, 1A1ci and 1B1c).....	127
Figure 38:1: Ferroalloy production process pathway.....	140
Figure 45:1: Process flow for pulp and paper industry.....	167

**ABBREVIATIONS**

BOD	biochemical oxygen demand
CCF	carbon content factor
CEM	continuous emissions monitoring
CEMS	continuous emissions monitoring systems
CGE	Consultative Group of Experts
CH	methane
CHP	combined heat and power generation
COF	carbon oxidation factor
CO <sub>2</sub>	carbon dioxide
CO	carbon monoxide
COD	chemical oxygen demand
CTL	coal-to-liquids
CTC	coal-to-chemicals
DOC	degradable organic carbon
EF	emission factor
FOD	first order decay
GCV	gross calorific value
GDG	greenhouse gas
GICS	Global Industry Classification Standards
Gg	Gigagrams
GTC	gas-to-chemicals
GTL	gas-to-liquids
HHV	high heating value
IPCC	Intergovernmental Panel on Climate Change
LHV	lower heating value
LPG	liquefied petroleum gas
MCF	methane correction factor
MSW	municipal solid waste
MW (th)	megawatt thermal
NAEIS	National Atmospheric Emissions Inventory System
NCV	net calorific value
NGERs	National Greenhouse Gas Emission Reporting Regulations
NMVOc	non-methane volatile organic compound
N <sub>2</sub> O	nitrous oxide
NO <sub>x</sub>	nitrogen oxides
SWDS	solid waste disposal site
SAGERS	South African Greenhouse Gas Emissions Reporting System
UNFCCC	United Nations Framework Convention on Climate Change
QA	quality assurance
QC	quality control

## GLOSSARY

**“activity data”** means data on the magnitude of a human activity resulting in emissions or removals taking place during a given period of time. Data on energy use, metal production, land areas, management systems, lime and fertiliser use and waste arising are examples of activity data;

**“boiler”** means a combustion appliance designed to heat water. In terms of these regulations, a boiler is referred to as a stationary combustion device;

**“combustion emissions”** means greenhouse gas emissions occurring during the exothermic reaction of a fuel with oxygen;

**“competent authority”** means the National Inventory Unit based at the National Department of Environmental Affairs;

**“data provider”** means any person as classified in regulation 4 and shall include:

- (a) its holding company or corporation or legal entity, registered in South Africa in accordance with the Legislation of South Africa;
- (b) all its subsidiaries and legally held operations, including joint ventures and partnerships where it has a controlling interest, or is nominated as the responsible entity for the purpose of reporting under these Regulations;
- (c) all facilities generally over which it has operational control, which are not part of another data provider as provided for in these Regulations;

**“default IPCC emission factors”** are emission factors provided in the 2006 IPCC Guidelines for National Greenhouse Gas Inventories and its associated supplementary information; these emission factors assume a linear relation between the intensity of the process and the resulting emissions and an average or typical process description;

**“emissions”** are the release of greenhouse gases/and/or their precursors into the atmosphere over a specified area and period of time;

**“design capacity”** means capacity as installed;

**“direct emission measurement”** means a set of operations having the objective of determining the value of a quantity by means of periodic or continuous measurement, applying either measurements in the stack or extractive procedures with a measuring instrument located close to the stack;

**“emissions”** are the release of greenhouse gases/and/or their precursors into the atmosphere over a specified area and period of time;

**“emission factor”** means a coefficient that quantifies the emissions or removals of a gas per unit of activity. Emission factors are often based on a sample of measurement data, averaged to develop a representative rate of emission for a given activity level under a given set of operating conditions;

**“IPCC emission source”** means any process or activity which releases a greenhouse gas, an aerosol or a precursor of a greenhouse gas into the atmosphere which is identified by IPCC code in Annexure 1;

**“facility”** means premises, where activities identified in Annexure 1 are being undertaken;

**“fugitive emissions”** means emissions that are not emitted through an intentional release through stack or vent. This can include leaks from industrial plant and pipelines;

**“greenhouse gas”** means any one of the following gases:  
Carbon dioxide (CO<sub>2</sub>), Methane (CH<sub>4</sub>), Nitrous oxide (N<sub>2</sub>O) Sulphur hexafluoride (SF<sub>6</sub>), Perfluorocarbons (PFCs), Hydrofluorocarbons (HFCs);

**“Global Warming Potential (GWP)”** means a metric that compares the radiative forcing of a tonne of a greenhouse gas over a given period (e.g., 100 years for the purpose of annual greenhouse gas inventory) to a tonne of Carbon Dioxide. By using GWPs, greenhouse gas emissions can be standardised to a carbon dioxide equivalent (CO<sub>2</sub>-eq);

**“installation”** means a device, operation or process that provides a particular service or is used for a particular industry. An installation generally performs one or more of the activities listed in annexure 1 and is housed within a facility;

**“IPCC Guidelines for National Greenhouse Gas Inventories (2006)”** means the guidelines developed by the IPCC for the establishment and maintenance of national greenhouse gas inventories and are available on the IPCC website ([www.ipcc.ch](http://www.ipcc.ch));

**“IPCC”** means the Intergovernmental Panel on Climate Change which is the international body for the assessment of climate change established by the United Nations Environment Programme (UNEP) and the World Meteorological Organization (WMO) in 1988;

**“National Atmospheric Emission Inventory System” or “NAEIS”** means the internet-based emissions reporting system that is a component of the South African Air Quality Information System;

**“operational control”** means a data provider has operational control or another company if it, or one of its subsidiaries, has the full authority to introduce and implement its operating policies at the company;

**“process emissions”** means greenhouse gas emissions other than combustion emissions occurring:

- (a) during use of specific substances;
- (b) as a result of intentional and unintentional reactions between substances or their transformation including the chemical or electrolytic reduction of metal ores, the thermal decomposition of substances, and;
- (c) the formation of substances for use as product or feedstock.

**“reporting period”** means one calendar year;

**“South African Air Quality Information System” or “SAAQIS”** means the national air quality information system established in terms of the National Framework for Air Quality Management in the Republic of South Africa;

**“Methodological Guidelines for Quantification of Greenhouse Gas Emissions ”** means the reporting methodology approved by the competent authority available on the National Department of Environmental Affairs website ([www.environment.gov.za/legislation/guidelines](http://www.environment.gov.za/legislation/guidelines));

**“the Act”** means the National Environmental Management: Air Quality Act, 2004 (Act No. 39 of 2004);

**“these Regulations”** include the Annexures to these Regulations;

**“tier”** means a method used for determining greenhouse gas emissions as defined by the “IPCC Guidelines for National Greenhouse Gas Inventories (2006)” and include

- (a) Tier 1 method: A method using readily available statistical data on the intensity of processes (activity data) and IPCC emission factors (specified in the Methodological Guidelines for Quantification of Greenhouse Gas Emissions or available from 2006 IPCC Guidelines);
- (b) Tier 2 method: similar to Tier 1 but uses country-specific emission factors;
- (c) Tier 3 method: Tier 3 is any methodology more detailed than Tier 2 and might include amongst others, process models and direct measurements as specified in the 2006 IPCC guidelines.

**“transparency”** means that the assumptions and methodologies used as a basis for reporting activity data and greenhouse gas emissions should be clearly explained to facilitate replication and assessment of the submitted information by users of the reported information;

**“upset conditions”** means any temporary failure or air pollution control equipment or process equipment or failure of a process to operate in a normal or usual manner that leads to abrupt increases or decreases in greenhouse gas emission rates;

**“validation”** means the establishment of sound approach and foundation. In the context of emissions inventories, validation involves checking to ensure that reported greenhouse gas emissions data have been compiled correctly in line with reporting instructions and guidelines. It checks the internal consistency of the inventory;

## 1. Introduction

This Methodological Guideline document describes the reporting methodology as specified in the National Environmental Management: Air Quality Act, 2004 (Act No. 39 of 2004) (NEMA): National Greenhouse Gas Emission Reporting Regulations (NGERs) (DEA 2016) (herein referred to as the Regulations).

All terms defined in the Regulations and used in these Methodological Guidelines have the same meaning as in the Regulations. The reporting company is referred to as the data provider throughout this guideline and in the Regulations. According to the NGERs, a data provider is defined as any person in control of or conducting an activity listed in Table 5.2 of this guideline and shall include —

- a) its holding company or corporation or legal entity, registered in South Africa in accordance with the Legislation of South Africa;
- b) all its subsidiaries and legally held operations, including joint ventures and partnerships where it has a controlling interest, or is nominated as the responsible entity for the purpose of reporting under these Regulations;
- c) all facilities generally over which it has operational control, which are not part of another data provider as provided for in these Regulations.

### 1.1. Purpose of the Methodological Guidelines

The purpose of these Methodological Guidelines is to provide additional guidance and commentary to assist data providers in estimating Greenhouse Gas (GHG) emissions for reporting on the Greenhouse Gas reporting module of the National Atmospheric Emission Inventory System (NAEIS). Guidance is provided to reporting companies on methodologies to apply when quantifying Greenhouse Gas emissions from activities listed in Table 5.2 of this guideline.

The Methodological Guidelines support:

- The process to update and maintain a National GHG Inventory;
- The Republic of South Africa to meet its reporting obligations under the United Framework Convention on Climate Change and instrument treaties to which it is bound; and;
- Formulation and implementation of legislation and policy.

One of the key objectives of the country is to transition towards a lower-carbon economy as reflected in the National Climate Change Response Policy (DEA 2011) and the National Development Plan 2030 (NDP) (NPC 2011). These Methodological Guidelines support the tracking of progress towards this transition to a lower-carbon economy by providing methodological guidance for quantification of greenhouse gas emissions.

## 2. Overview

There are key differences between corporate GHG inventories and a national GHG inventory, both in terms of calculations and reporting requirements. Many companies in South Africa have been reporting their GHG emissions voluntarily for a number of years, primarily through the CDP (formerly the Carbon Disclosure Project), while at the same time national government has been reporting South Africa's emissions as part of National Communications to the United Nations Framework Convention on Climate Change (UNFCCC), in order for the UNFCCC to have accurate data on GHG emissions trends for countries.

The South African Government, through the Regulations, has introduced mandatory reporting which implies that some emitters will be required to report their emissions to the government. These Methodological Guidelines will enable emitters to report GHG emissions information as required by the Regulations.

While corporate reporting and national reporting have developed independently of each other, they have the potential to complement each other and enable decision-makers to understand national and sector trends, as well as to inform mitigation activities (Singh et al., 2015).

The sections below aim to support companies and governments to understand the differences between reporting at a national level and at a company level, to ensure that the varying approaches are aligned in a way that is beneficial to government and business alike.

### 2.1. UNFCCC reporting requirements

In accordance with Article 4, paragraph 1 and Article 12, paragraph 1 of the Convention, each Party (UNFCCC signatories) shall communicate to the Conference of the Parties, through the secretariat, the following elements of information:

- (a) A national inventory of anthropogenic emissions by sources and removals by sinks of all greenhouse gases not controlled by the Montreal Protocol, to the extent its capacities permit, using comparable methodologies to be promoted and agreed upon by the Conference of the Parties (UNFCCC 1992, p15).

Guidelines for the preparation of initial national communications from non-Annex I Parties were adopted at COP 2 in Geneva in 1996. COP 5 (Bonn, 1999) initiated a process of reviewing the guidelines, with the aim of improving them and established a Consultative Group of Experts (CGE) on national communications from non-Annex I Parties in order to improve the process of preparing their national communications. The CGE made major contributions to the review of the guidelines. At COP 8 (New Delhi, 2002) Parties adopted revised guidelines, which will be the basis for the preparation of second and, where appropriate, third and initial national communications (UNFCCC 2003, 2).



## 2.2. Use of the IPCC Guidelines as basis for these Methodological Guidelines

The structure of this Methodological Guideline for calculation of emission sources and sinks follows the structure suggested by the 2006 Intergovernmental Panel on Climate Change (IPCC) Guidelines, the South African GHG Standard. As such, the methodologies presented in this document have been mostly based on the 2006 IPCC Guidelines. A significant amount of material contained herein is from the 2006 IPCC Guidelines (unless stated otherwise), summarised to enhance user friendliness.

The National Air Quality Act, 2004 (Act No.39 of 2004) and the National Greenhouse Gas Emissions Reporting Regulations, 2016 (NGERs) under that Act establish the legislative framework for a national GHG reporting system (DEA 2016).

These Methodological Guidelines embody the latest methods for estimating emissions and as stated above are based on the 2006 IPCC Guidelines for compilation of National Greenhouse Gas inventories. The Methodological Guidelines provide additional guidance and commentary to assist data providers in estimating greenhouse gas emissions for reporting in the South African Greenhouse Gas Reporting System (SAGERS) – which is a web-based platform through which reporting will be done, and in general are applicable once the NGERs are promulgated. In addition, these guidelines will be subject to review annually depending on the availability of new methodologies, emission factors and refinements to existing methodologies.

## 2.3. Thresholds for reporting

The NGERs make reporting mandatory for data providers whose energy production, energy consumption, or greenhouse gas emissions meet certain specified thresholds. These thresholds are detailed in Annexure 1 of the NGERs and Table 5:2 of this Methodological Guideline. For energy sector (combustion), the threshold is cumulative across the activities. This means that if you have two types of activities (e.g 1A5a and 1A4a), the threshold would be the total of all 1A5a and 1A4a installed capacities.

Descriptions of emissions sources and estimation methods are based on those provided in the 2006 IPCC Guidelines for National Greenhouse Gas Inventories (IPCC 2006) and used by the Department in preparing the Government's annual submission to the United Nations Framework Convention on Climate Change (UNFCCC).

## 2.4. Emissions

Emissions are defined in the Regulations as the release of greenhouse gases/and/or their precursors into the atmosphere over a specified area and period of time.

The Methodological Guidelines are largely concerned with direct emissions arising from the activities listed in Table 5:2 of these Methodological Guidelines.

The greenhouse gases covered by these guidelines are defined in the Regulations and include:

- carbon dioxide (CO<sub>2</sub>)

- methane (CH<sub>4</sub>)
- nitrous oxide (N<sub>2</sub>O)
- hydrofluorocarbons (HFCs)
- perfluorocarbons (PFCs)
- sulphur hexafluoride (SF<sub>6</sub>)

### 2.5. Emission sources:

Emission sources are defined in the regulations as “any process or activity which releases a greenhouse gas, an aerosol or a precursor of a greenhouse gas into the atmosphere which is identified by the IPCC code in Annexure 1 of the NGERs (DEA 2016, 14).

Coverage of emission sources in the NGERs is given for the following categories using the numbering employed in the IPCC 2006 guidelines as given in Table 5:2:

- (1A) Fuel combustion, which deals with emissions released from fuel combustion activities.
- (1B) Fugitive emissions from fuels, which deals with emissions mainly released from the extraction, production, processing, and distribution of fossil fuels.
- (2) Industrial processes emissions, which deals with emissions released from the consumption of carbonates and the use of fuels as feed stocks or as carbon reductants, and the emission of synthetic gases in particular cases.
- (4) Waste emissions, which deals with emissions mainly released from the decomposition of organic material in landfills or wastewater handling facilities and waste incineration.

In South Africa, stationary fuel combustion remains one of the key sources of greenhouse gas emissions accounting for over 60% of emissions reported in the national GHG inventory (DEA 2014).

The scope of activities listed for mandatory reporting as per Table 5:2 does include land-based emissions covered by the UNFCCC categories ‘Agriculture’ and ‘Land Use, Land Use Change and Forestry’ as per the amendment of the NGERs, 2016. Emissions from fuel combustion or any other emission source listed above, and which originate from a facility operating within a land-based industry are also covered by the Determination.

### 2.6. Updates of these Guidelines

It is recognised that these Methodological Guidelines will need to be updated as amendments are made to methodologies, emission factors and activity data on an annual basis.

Amendments to the Methodological Guidelines are made to reflect new information on emissions estimation methods.

Where required, updates to these guidelines will also provide methods for emission sources where there are currently gaps or omissions in the Methods currently available.

### 2.7. Methods for measurement

Emissions are rarely measured through direct observation and are most often estimated by reference to readily observable variables that are closely related to greenhouse gas emissions such as the quantity of fossil fuels consumed (referred to as activity data).

These Guidelines provide methods that allow for both direct emissions monitoring and the estimation of emissions through the tracking of observable, closely related variables.

At its simplest, emissions may be estimated by reference to reportable data such as fossil fuel consumption, evidenced by invoices, and the use of specified emission factors provided in these Guidelines. For emissions from fuel combustion, for example, data on consumption of a particular fuel would be multiplied by a specific emission factor for that fuel to generate an emissions estimate.

Greater levels of complexity and measurement effort may in some circumstances produce better estimates of emissions at facility level. This may result from, for example, sampling and analysis of a fuel consumed for its carbon content and other qualities that will affect actual emissions generated by its combustion at a facility. In South Africa, this kind of approach to emissions estimation has been used for a number of years in most industry sectors.

Direct monitoring of emissions is also potentially an important approach to emissions estimation. While not common, such direct monitoring already occurs in some form in some instances such as in the coal industry and power generation.

Each of these broad approaches has been incorporated into the Guidelines as Methods for the estimation of emissions.

In particular, four methods have been described which provide a framework for emissions estimation for a range of purposes.

The provision for data providers to select Methods for the estimation of emissions also allows them to make their own judgements to balance the costs of using the higher-tier methods with the benefits of potentially improved emission estimates. For some key emitting sectors, there are transitional arrangements<sup>1</sup> wherein, for a specific IPCC emission source and greenhouse gas, higher tier IPCC methodologies have to be used after a five-year period from the date of promulgation of the NGERs.

### 2.8. Registration within SAGERS

Once a company has established that they meet the reporting thresholds as per Table 5:2, they must register within SAGERS by following the link below, additional guidance on the registration is available on the SAGERS Landing Page: <https://ghgreporting-public.environment.gov.za/GHGLanding/SAGERSHome.html>  
Login Page: <https://ghgreporting-public.environment.gov.za/>

<sup>1</sup> Transitional Arrangements are described in regulation 15 of the NGERs (DEA 2016).

### 3. Commonalities and Differences between the IPCC Guidelines and the Corporate Standard

**The IPCC Guidelines are categorised according to activities, while the Corporate Standard (GHG Protocol 2004) focuses more on sectors. This means that the categories that companies use to report emissions might be different.**

The IPCC Guidelines divide emissions into four main categories, termed sectors, which are further divided into several subsectors. The sectors refer to activities that emit GHGs. The four main sectors are:

- Energy
- Industrial Processes and Product Use (IPPU)
- Agriculture, Forestry and other Land Use (AFOLU)
- Waste

Therefore, a company's emissions will not fall into one IPCC sector, but would include activities in various sectors.

Using the term sectors can be unclear for businesses that define sectors according to the Johannesburg Stock Exchange (JSE) sectoral classification, based on the Industry Classification Benchmark or the Global Industry Classification Standards (GICS). The CDP uses the GICS system for companies reporting GHG emissions in their CDP response.

Companies reporting according to the Corporate Standard do not always break down their emissions by activity type. In cases where companies do break down their emissions by activity type, the activities listed may not be in the same source categories that are used in the IPCC Guidelines. IPCC categories and sub-categories are used to distinguish between different sources of emissions in the different sectors.

**Under the IPCC Guidelines companies might have to start reporting emissions from sources that they previously have not reported on.**

Companies reporting their emissions voluntarily in some instances have omitted certain emissions, not because the Corporate Standard does not require them to be reported but because there is a lack of data or the emissions were classified as immaterial, and in some instances these emission sources were unknown. The IPCC Guidelines require that these emissions are reported, so companies will need to begin calculating and reporting them as, over time, these categories will be phased in and become a national requirement.

**Both the IPCC Guidelines and the Corporate Standard require that GHGs need to be reported separately.**

Both the IPCC Guidelines and the GHG Protocol Corporate Standard require that emissions are reported separately. However, companies responding voluntarily, for example, to the CDP are not required to separate their GHG emissions.

Many companies use an emissions factor that converts data into carbon dioxide equivalents (CO<sub>2</sub>e) that include the non-CO<sub>2</sub> greenhouse gases, for example the UK Department of Environment, Food

and Rural Affairs (DEFRA) gives emission factors in CO<sub>2</sub>e. While some other companies use supplier specific emission factors that do not include separate emission factors for all GHGs.

**The IPCC Guidelines use a tiered approach to describe different methods of calculating GHG emissions. This is new terminology for companies using the GHG Protocol standards.**

For various categories of emission activities, the IPCC Guidelines provide several options for calculating the emissions, described as tiers. There are three levels of tiers: tier 1, tier 2, and tier 3. Each tier has an associated increasing level of detail and accuracy, with the tier 3 method being the most accurate approach. While the tiered approach is mentioned in some of the GHG Protocol's sector-specific guideline documents, it is not explained in the Corporate Standard.

**Companies will have to use emission factors provided in the 2006 IPCC requirements.**

An emission factor is a value that quantifies emissions associated with an activity (for example fuel consumption). The IPCC provides 'default emission factors' for different fuels and activities. These default emission factors are considered to be less accurate than country-specific factors and even less accurate than company-specific factors. In the case of reporting under the IPCC Guidelines, it is recommended to use country or plant specific emissions factors for key categories. In instances where country or plant specific emission factors are not available, then it is recommended that IPCC default factors are used.

In some cases, companies use emission factors that are not country/plant-specific or default IPCC factors. For example, the UK Department for Environment, Food and Rural Affairs (DEFRA) or the US Environmental Protection Agency (EPA) emission factors are often used for corporate GHG reporting purposes. In these instances, to ensure consistency across reporting companies, companies would need to align their emission factors with the default IPCC emission factors. For key categories the IPCC Guidelines recommends that country- or plant-specific emission factors are determined, to improve the accuracy of reporting.

The IPCC Guidelines recommend that when calculating non-CO<sub>2</sub> GHG emissions, the most recent Global Warming Potentials (GWPs) are used. However, under NGERs, which stipulates national reporting requirements, data providers are required to use GWP values provided by the IPCC 3<sup>rd</sup> Assessment Report (IPCC 2001), where required. When reporting on the SAGERS Portal, data providers are required to report direct emissions and not CO<sub>2</sub>eq. The system will generate a report based on the relevant GWPs when the data provider downloads the annual report. A GWP is a measure of how much a GHG contributes to global warming relative to CO<sub>2</sub>. The GHG Protocol however states that the IPCC 2<sup>nd</sup>, 3<sup>rd</sup> or 4<sup>th</sup> Assessment Report GWPs can be used, as long as they are referenced correctly and used consistently. Annexure G of this Methodological Guideline provides a list of GWPs that data providers can use. In annexure G please use the 100-year GWP values highlighted in bold.

**CO<sub>2</sub> emissions from biomass combustion for energy purposes are reported separately for the IPCC Guidelines and the GHG Protocol Corporate Standard. When reporting GHG emissions in terms of the NGERs, 2016, biomass combustion must be reported, however the emission from this activity is excluded from the total emissions on the SAGERS Portal.**

Biomass is commonly used as a fuel, often in combination with fossil fuels. Like the GHG

Protocol, the IPCC Guidelines state that CO<sub>2</sub> emissions from biomass fuels are reported separately and are not included in sector or national totals to avoid double counting (IPCC 2006, Volume 2 Energy, page 1.19). Also similar to the Corporate Standard, the IPCC Guidelines require that methane (CH<sub>4</sub>) and nitrous oxide (N<sub>2</sub>O) emissions from biomass burning are included in sector and national totals because these gases are not sequestered during growth and in addition to stock changes associated with land use activities.

When biomass is used in combination with fossil fuels, companies would need to ensure that CO<sub>2</sub> emissions from biomass are separated from fossil fuel emissions.

**Energy and emission units for the IPCC Guidelines are specific.**

The IPCC Guidelines use SI units (International System of Units) for its calculations and for reporting emissions.

Greenhouse gas emissions under this national GHG emissions reporting programme are reported in tonnes. Companies reporting to the CDP are requested to report their emissions in tonnes, while the GHG Protocol does not require emissions to be reported in specific units.

These Guidelines use net calorific values (NCVs), expressed in SI units or multiples of SI units (for example TJ/l). Some countries use gross calorific values (GCV). The difference between NCV and GCV is the latent heat of vaporisation of the water produced during combustion of the fuel. As a consequence, for coal and oil, the NCV is about 5 percent less than the GCV. For most forms of natural and manufactured gas, the NCV is about 10 percent less.

The IPCC Guidelines require that emissions should be reported for a calendar year, while the Corporate Standard requires emissions to be reported for a year, which could also be a financial year.

Table 3:1 below provides a summary of the key IPCC reporting requirements, as described above, highlighting what these requirements would mean for companies and government.

**Table 3:1: Summary of key IPCC reporting requirements and implications for companies and government**

Good practice IPCC Guidance	Implications for business
<b>Identify relevant IPCC Boundary</b>	
Companies reporting for national requirements must only report South African data.	Companies need to exclude emissions from facilities in other countries in their calculations, by allowing for their data collection methods to separate emissions from other countries.
Companies only need to report direct emissions, which will most likely only be on-site emissions.	Companies may need to change the consolidation approach they apply to ensure that direct emissions are consistent across all companies.
Transport emissions are broken down into off-site and on-site transportation	In terms of the greenhouse gas reporting regulations, companies do <b>not need to report emissions associated with off-site and on-site road transportation.</b>
<b>Identify relevant IPCC sources of emissions</b>	

<b>Good practice IPCC Guidance</b>	<b>Implications for business</b>
Emissions need to be categorised into IPCC sectors	Companies will have to understand that IPCC sectors are GHG activity based, and not economic sector based and align their emissions sources with the IPCC sectors.
The six GHGs need to be reported separately	Companies need to start calculating individual GHG emissions (where relevant).
<b>Collecting data and calculating emissions</b>	
Understand the IPCC tiered methodological approach	Depending on sectoral IPCC guidance as well as the methodology transitional arrangement stipulated in the greenhouse gas reporting regulations, companies may need to calculate emissions differently.
Use emission factors and Global Warming Potentials (GWPs) in line with IPCC requirements	In some instances, companies may be required to use different emission factors and GWPs, so emissions reported may be different to what is reported voluntarily. When reporting on SAGERS, direct emissions are reported and not CO <sub>2eq</sub> . Therefore, conversion to CO <sub>2eq</sub> using GWPs will not be required.
CO <sub>2</sub> emissions from biomass combustion for energy purposes are reported separately but report CH <sub>4</sub> and N <sub>2</sub> O emissions from biomass	Companies need to report CH <sub>4</sub> and N <sub>2</sub> O emissions from biomass burning.
<b>Reporting emissions</b>	
Ensure that energy and emission units are in line with the IPCC Guidelines	Companies need to ensure that NCVs are used, and emissions are reported in Tonnes
Emissions should be reported for a calendar year	Emission totals will need to be reworked to suit the required reporting year.  Monthly recording of data would enable and simplify this process.
The IPCC Guidelines require some form of QA, QC and verification, which is not a requirement under the GHG Protocol	The Department of Forestry, Fisheries and the Environment will perform the verification process of emissions reported in accordance with the assessment process detailed in the greenhouse gas emissions reporting regulations.

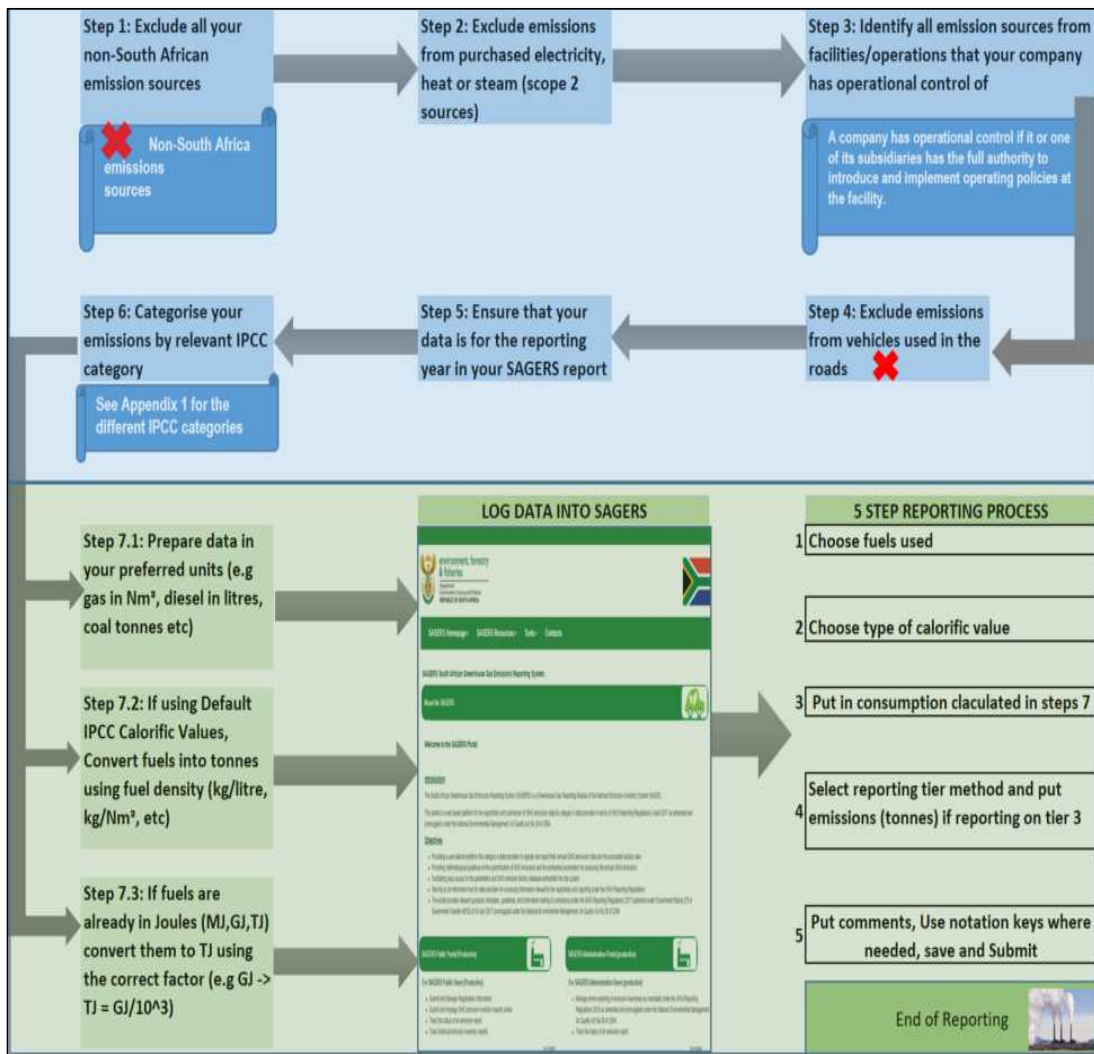

Figure 3.1: A step-by-step approach to reporting corporate emissions in the SAGERS Portal

### 3.1. Selection of Net Calorific Values (NCVs)

When reporting fuel combustion, energy must be reported on a net basis. To report on net basis, a net calorific value (NCV) is used. Within SAGERS there are three types of NCV types that the user can select when reporting fuel use. These are:

- a) Default IPCC Calorific Value
- b) Country Specific Net Calorific Value and
- c) Supplier Specific Net Calorific Value

The differentiating factor between the three of the values is where they come from. Default IPCC Calorific Value is given by IPCC specifically from 2006 IPCC Reporting Guidelines and is represented in TJ/tonne. Country Specific NCV is developed within the country and within SAGERS it is important to note that solid, gas (except LPG) and liquid fuels have differing units as shown in Table 3.2. Once country specific net calorific values are established, they will be added to the



SAGERS system to be available for everyone to use. The supplier specific NCV comes directly from the Company reporting. **Once you use Supplier Specific NCV, please provide additional supporting information to justify why you are using it. The additional supporting information is mainly the laboratory analysis report of the fuel showing the fuel properties including the net calorific value, fuel composition.** It is advisable to use SANAS Accredited labs for this analysis. In some cases, the supporting documentation is the invoice where the net calorific value of the fuel is stated. In cases where you use an invoice the fuel supplier must share the laboratory analysis document about the fuel, so that it is submitted.

**Table 3:2: NCV types and corresponding activity units**

NCV Type	Explanations	Units applicable		Consumption
IPCC Default Calorific Value	Default net calorific value given by IPCC	TJ/Tonne		Tonnes
Country-Specific Calorific Value	Calorific value determined within a country	TJ/L	Liquids	Litres
		TJ/Tonne	Solids	Tonnes
		TJ/m <sup>3</sup>	Gases	Cubic metres
Supplier Specific	Calorific value as per fuel specification of supplier given information	User dependent		Specific to NCV units used

### 3.2. Exclusion of Mobile Transportation Fuel

**Fuel used in vehicles and mobile applications is not supposed to be reported in SAGERS as shown in Figure 3:1.** For example, when conducting mining operations, fuel used in stationary applications is reported while fuel used within forklifts and any equipment that moves the material around the mining operation is excluded from the reported emissions.

## 4. Structure of this Methodological Guideline

The structure of this guideline is based on the general structure of sectoral guidance in the 2006 IPCC Guidelines, as shown below:

- IPCC classification
- Choice of Method, including process flow diagrams and definition of Tiers.
- Choice of Activity Data
- Choice of Emission Factor

General guidance is described in the main body of this Methodological Guideline. Any sector specific guidance is described in the subsector Annexures.

### 4.1. IPCC Structure

These Methodological Guidelines refer to three of the four IPCC categories:

- Energy:
  - stationary combustion of fuels
  - domestic aviation industry
  - water-borne navigation
  - railway transport
  - fugitive emissions from coal mining
  - fugitive emission from oil and gas operations
- Industrial Processes and Product Use:
  - mineral industry
  - chemical industry
  - metal industry
- Waste
  - solid waste disposal
  - wastewater treatment;
  - waste incineration
- AFOLU
  - manure management
  - land
  - aggregate sources and non-CO<sub>2</sub> emissions sources on land
  - harvested wood products

## 5. Reporting

The main body of the Methodological Guidelines provides a general description that is relevant to all data providers. More detail for specific subsectors is provided in the Annexures that follow.

Data providers should take note that even though their main activities may be covered in the reporting subsectors below, their operations could include a wider scope of activities, in which case data providers should report under the categories covering all their material activities.

Table 5.1: Reporting subsector/activities

Reporting Subsectors and/or Activities	Section
<b>Energy</b>	
Stationary Combustion	12
Electricity + Heat Generation	13
Combined Heat and Power	14
Charcoal Production	15
Biochar Production	16
Coke Production	17
Oil and Gas Industry including Petroleum Refining	18
Coal-to-liquids and Gas-to-liquids Processes	19
Aviation Industry	20
Water-borne Navigation	21
Railways	22
Mining of Fuels	23
Mining and Quarrying	24
Carbon Capture and Storage	25
<b>Industrial Processes and Product Use</b>	
Cement Production	26
Lime Production	27
Glass Production	28
Other Process Uses of Carbonates	29
Ammonia Production	30
Nitric Acid Production	31
Carbide Production	32
Titanium dioxide Production	33
Soda Ash Production	34
Petrochemical and Carbon Black Production	35
Hydrogen Production	36
Iron and Steel Production	37
Ferrous alloys and Other Metal Production	38
Aluminium Production	39
Magnesium Production	40
Lead Production	41
Zinc Production	42
Other	43
Other Product and Manufacture Use	4443
Pulp and Paper Industry	45
<b>Waste</b>	

Solid Waste (on-site waste disposal)	46
Wastewater (Industry Wastewater)	47
Waste Incineration	49
<b>AFOLU</b>	
Poultry	50
Forestland Remaining Forestland	51
Land Converted to Forest Land	52
Biomass Burning in Forest Lands	53
Direct N <sub>2</sub> O Emissions from Managed Soils	54
Indirect N <sub>2</sub> O Emissions from Managed Soils	55
Harvested Wood Products	56

In assessing the methodological guidance provided in the sections listed in the table above, data providers must pay attention to the IPCC tier methods recommended for each IPCC emission source and relevant greenhouse gases.

There are reporting categories that should be dealt with on a national level through national surveys. These emissions should not, therefore, have to be calculated and are excluded from reporting by individual companies. These categories would include emissions relating to activities such as refrigeration and air conditioning, and fire protection as well as a number of mobile combustion subcategories. See Annexure E for Definitions of the Source categories listed in the table below.

Table 5.2: IPCC source categories and their associated Thresholds (NGERs, 2016)

IPCC Code	Activity Name	shall report when their total installed capacity for this activity is equal or above the threshold	Category A	
			Threshold	Transitional Arrangement Applicability (Regulation 15)
<b>1</b>	<b>ENERGY</b>			
<b>1A</b>	<b>Fuel Combustion Activities</b>			
<b>1A1</b>	Energy Industries			
1A1a	Main Activity Electricity and Heat Production	Tier 2 or 3	10 MW(th) <sup>2</sup>	YES <sup>3</sup>
1A1b	Petroleum Refining	Tier 2 or 3	10 MW(th)	YES
1A1c	Manufacture of Solid Fuels and Other Energy Industries	Tier 2 or 3	10 MW(th)	YES
<b>1A2</b>	<b>Manufacturing Industries and Construction</b>			
1A2a	Iron and Steel	Tier 2 or 3	10 MW(th)	YES
1A2b	Non-Ferrous Metals	Tier 2 or 3	10 MW(th)	YES
1A2c	Chemicals	Tier 2 or 3	10 MW(th)	YES
1A2d	Pulp, Paper and Print	Tier 2 or 3	10 MW(th)	YES
1A2e	Food Processing, Beverages and Tobacco	Tier 2 or 3	10 MW(th)	NO
1A2f	Non-Metallic Minerals	Tier 1, 2 or 3	10 MW(th)	YES
1A2g	Transport Equipment	Tier 1, 2 or 3	10 MW(th)	NO
1A2h	Machinery	Tier 1, 2 or 3	10 MW(th)	NO
1A2i	Mining and Quarrying	Tier 2 or 3	10 MW(th)	YES
1A2j	Wood and Wood Products	Tier 1, 2 or 3	10 MW(th)	NO
1A2k	Construction	Tier 1, 2 or 3	10 MW(th)	NO
1A2l	Textile and Leather	Tier 1, 2 or 3	10 MW(th)	NO

<sup>2</sup> This threshold refers to a combined design capacity equal to or above 10 MW (th) net heat input. For example, the combined boiler design capacity for six (6) 2MW(th) boilers is equal to 12 MW (th) which is above the reporting threshold of 10MW (th). Therefore, the data provider has to report greenhouse gas emissions associated with stationary combustion in this case.

<sup>3</sup> a YES implies that a data provider has to apply a tier 2 or tier 3 methodology for the relevant IPCC source code after 5 years from the date of promulgation of these regulations.

IPCC Code	Activity Name	shall report when their total installed capacity for this activity is equal or above the threshold	Category A	
			Threshold	Transitional Arrangement Applicability (Regulation 15)
1A2m	Brick manufacturing:	Tier 1, 2 or 3	1 million bricks a month	NO
1A2n	Manufacture of ceramic products by firing in particular roofing tiles, tiles, stoneware or porcelain	Tier 1, 2 or 3	With a production capacity equal or greater than 5 tonnes per day	NO
<b>1A3</b>	<b>Transport</b>			
1A3a	Civil Aviation	Tier 2 or 3	100 000 litres/year	Yes
1A3b	Road Transportation	NA <sup>4</sup>	NA	NO
1A3c	Railways	Tier 2 or 3	100 000 litres/year	Yes
1A3d	Water-borne Navigation	Tier 2 or 3	100 000 litres/year	Yes
1A3e	Other Transportation	NA	NA	NA
<b>1A4</b>	<b>Other Sectors</b>			
1A4a	Commercial/Institutional	Tier 2 or 3	10 MW(th)	YES
1A4b	Residential	Tier 2 or 3	10 MW(th)	YES
1A4c	Agriculture/Forestry/Fishing/Fish Farms	Tier 2 or 3	10 MW(th)	YES
<b>1A5</b>	<b>Non-Specified</b>			
1A5a	Stationary	Tier 2 or 3	10 MW(th)	YES
1A5b	Mobile	NA	NA	NA
1A5c	Multilateral Operations	NA	NA	NA
<b>1B</b>	<b>Fugitive Emissions from Fuels</b>			
<b>1B1</b>	<b>Solid Fuels</b>			
1B1a	Coal Mining and Handling	Tier 2 or 3	<sup>5</sup> none	YES
1B1b	Uncontrolled Combustion, and Burning Coal Dumps	NA	NA	NA
1B1c	Solid Fuel Transformation	Tier 2 or 3	none	YES
<b>1B2</b>	<b>Oil and Natural Gas</b>			
1B2a	Oil	Tier 1, 2 or 3	none	NO
1B2b	Natural Gas	Tier 1, 2 or 3	none	NO
1B3	Other Emissions from Energy Production	Tier 2 or 3	none	YES
<b>1C</b>	<b>Carbon Dioxide Transport and Storage</b>			
1C1	Transport of CO <sub>2</sub>	Tier 1, 2 or 3	none	NO
1C1a	Pipelines	NA	10 000 tons CO <sub>2</sub> /year	NO
1C1b	Ships	Tier 1, 2 or 3	10 000 tons CO <sub>2</sub> /year	NO
1C1c	Other (please specify)	Tier 1, 2 or 3	10 000 tons CO <sub>2</sub> /year	NO
1C2	Injection and Storage			
1C2a	Injection	Tier 1, 2 or 3	10 000 tons CO <sub>2</sub> /year	NO
1C2b	Storage	Tier 1, 2 or 3	10 000 tons CO <sub>2</sub> /year	NO
1C3	Other	NA	NA	NA
<b>2</b>	<b>INDUSTRIAL PROCESSES AND PRODUCT USE</b>			
<b>2A</b>	<b>Mineral Industry</b>			
2A1	Cement Production	Tier 2 or 3	none	YES
2A2	Lime Production	Tier 2 or 3	none	YES
2A3	Glass Production	Tier 2 or 3	none	YES
2A4	Other Process Uses of Carbonates	Tier 1, 2 or 3		NO

<sup>4</sup> NA – Not Applicable. This means that data providers do not need to report emissions associated with activities listed with NA in this table.

<sup>5</sup> If the threshold for a specific IPCC source category in this table is reflected as none, it means that the data provider has to report activity data and greenhouse gas emissions irrespective of the size of greenhouse gas emissions and the scale of the operation of the activity

IPCC Code	Activity Name	shall report when their total installed capacity for this activity is equal or above the threshold	Category A	
			Threshold	Transitional Arrangement Applicability (Regulation 15)
2A4a	Ceramics	Tier 1, 2 or 3	50 tonnes of production a month	NA
2A4b	Other Uses of Soda Ash	Tier 1, 2 or 3	50 tonnes of production a month	NA
2A4c	Non-Metallurgical Magnesia Production	Tier 1,2 or 3	none	YES
2A4d	Other (please specify)	Tier 1,2 or 3	20 tonnes of production a month	NO
2A5	Other (please specify)	NA	NA	NO
<b>2B</b>	<b>Chemical Industry</b>			
2B1	Ammonia Production	Tier 2 or 3	none	YES
2B2	Nitric Acid Production	Tier 2 or 3	none	YES
2B3	Adipic Acid Production	Tier 2 or 3	none	YES
2B4	Caprolactam, Glyoxal and Glyoxylic Acid Production	Tier 2 or 3	none	YES
2B5	Carbide Production	Tier 2 or 3	none	YES
2B6	Titanium Dioxide Production	Tier 2 or 3	none	YES
2B7	Soda Ash Production	Tier 2 or 3	none	YES
2B8	Petrochemical and Carbon Black Production	Tier 2 or 3	none	YES
2B8a	Methanol	Tier 2 or 3	none	YES
2B8b	Ethylene	Tier 2 or 3	none	YES
2B8c	Ethylene Dichloride and Vinyl Chloride Monomer	Tier 2 or 3	none	YES
2B8d	Ethylene Oxide	Tier 2 or 3	none	YES
2B8e	Acrylonitrile	Tier 2 or 3	none	YES
2B8f	Carbon Black	Tier 2 or 3	none	YES
2B8g	Hydrogen Production	Tier 2 or 3	None	YES
2B9	Fluorochemical Production			
2B9a	By-product Emissions	Tier 1,2 or 3	none	NO
2B9b	Fugitive Emissions	Tier 1,2 or 3	none	NO
2B10	Other (Please specify)	Tier 1,2 or 3	20 tonnes of production a month	NO
<b>2C</b>	<b>Metal Industry</b>			
2C1	Iron and Steel Production	Tier 2 or 3	none	YES
2C2	Ferroalloys Production	Tier 2 or 3	none	YES
2C3	Aluminium Production	Tier 2 or 3	none	YES
2C4	Magnesium Production	Tier 2 or 3	none	YES
2C5	Lead Production	Tier 2 or 3	none	YES
2C6	Zinc Production	Tier 2 or 3	none	YES
2C7	Other (please specify)	Tier 2 or 3	50 tonnes of production a month	NO
<b>2D</b>	<b>Non-Energy Products from Fuels and Solvent Use</b>			
2D1	Lubricant Use	NA	NA	NO
2D2	Paraffin Wax Use	NA	NA	NO
2D3	Solvent Use	NA	NA	NO
2D4	Other (please specify)	NA	NA	NO
<b>2E</b>	<b>Electronics Industry</b>			
2E1	Integrated Circuit or Semiconductor	NA	NA	NA
2E2	TFT Flat Panel Display	NA	NA	NA
2E3	Photovoltaics	NA	NA	NA
2E4	Heat Transfer Fluid	NA	NA	NA
2E5	Other (please specify)	NA	NA	NA
<b>2F</b>	<b>Product Uses as Substitutes for Ozone Depleting Substances</b>			
2F1	Refrigeration and Air Conditioning	NA	NA	NA
2F1a	Refrigeration and Stationary Air Conditioning			
2F1b	Mobile Air Conditioning	NA	NA	NA
2F2	Foam Blowing Agents	NA	NA	NA
2F3	Fire Protection	NA	NA	NA
2F4	Aerosols	NA	NA	NA
2F5	Solvents	NA	NA	NA
2F6	Other Applications (please specify)	NA	NA	NA
<b>2G</b>	<b>Other Product Manufacture and Use</b>			
2G1	Electrical Equipment	NA	NA	NA
2G1a	Manufacture of Electrical Equipment	NA	NA	NA

IPCC Code	Activity Name	shall report when their total installed capacity for this activity is equal or above the threshold	Category A	
			Threshold	Transitional Arrangement Applicability (Regulation 15)
2G1b	Use of Electrical Equipment (SF <sub>6</sub> use)	Tier 1, 2 or 3	50 kg per year	NO
2G1c	Disposal of Electrical Equipment			
2G2	SF <sub>6</sub> and PFCs from Other Product Uses	NA	NA	NA
2G2a	Military Applications	NA	NA	NA
2G2b	Accelerators	NA	NA	NA
2G2c	Other (please specify)	NA	NA	NA
2G3	N <sub>2</sub> O from Product Uses	NA	NA	NA
2G3a	Medical Applications	NA	NA	NA
2G3b	Propellant for Pressure and Aerosol Products	NA	NA	NA
2G3c	Other (Please specify)	NA	NA	NA
2G4	Other (Please specify)	NA	NA	NA
2H	<b>Other</b>			
2H1	Pulp and Paper Industry	NA	NA	NA
2H2	Food and Beverages Industry	NA	NA	NA
2H3	Other (please specify)	NA	NA	NA
3	<b>AGRICULTURE, FORESTRY, AND OTHER LAND USE</b>			
3A	Livestock			
3A1	Enteric Fermentation			
3A1a	Cattle	NA	NA	NA
3A1b	Buffalo	NA	NA	NA
3A1c	Sheep	NA	NA	NA
3A1d	Goats	NA	NA	NA
3A1e	Camels	NA	NA	NA
3A1f	Horses	NA	NA	NA
3A1g	Mules and Asses	NA	NA	NA
3A1h	Swine	NA	NA	NA
3A1j	Other (please specify)	NA	NA	NA
3A2	Manure Management			
3A2a	Cattle	NA	NA	NA
3A2b	Buffalo	NA	NA	NA
3A2c	Sheep	NA	NA	NA
3A2d	Goats	NA	NA	NA
3A2e	Camels	NA	NA	NA
3A2f	Horses	NA	NA	NA
3A2g	Mules and Asses	NA	NA	NA
3A2h	Swine	NA	NA	NA
3A2i	Poultry	Tier 1, 2 or 3	With 40 000 places for poultry	NO
3A2j	Other (please specify)	NA	NA	NA
3B	<b>Land</b>			
3B1	Forest Land			
3B1a	Forest land Remaining Forest Land	Tier 1, 2 or 3	Equal or greater than 100 Hectares of Plantations	YES
3B1b	Land Converted to Forest Land	Tier 1, 2 or 3	Equal or greater than 100 Hectares of Plantations	YES
3B2	Cropland			
3B2a	Cropland Remaining Cropland	NA	NA	NA
3B2b	Land Converted to Cropland	NA	NA	NA
3B3	Grassland			
3B3a	Grassland Remaining Grassland	NA	NA	NA
3B3b	Land Converted to Grassland	NA	NA	NA
3B4	Wetlands			
3B4a	Wetlands Remaining Wetlands	NA	NA	NA
3B4b	Land Converted to Wetlands	NA	NA	NA
3B5	Settlements			
3B5a	Settlements Remaining Settlements	NA	NA	NA
3B5b	Land Converted to Settlements	NA	NA	NA
3B6	Other Land			
3B6a	Other Land Remaining Other Land	NA	NA	NA
3B6b	Land Converted to Other Land	NA	NA	NA
3C	<b>Aggregate Sources and Non-CO<sub>2</sub> Emissions Sources on Land</b>			
3C1	Emissions from Biomass Burning			

IPCC Code	Activity Name	shall report when their total installed capacity for this activity is equal or above the threshold	Category A	
			Threshold	Transitional Arrangement Applicability (Regulation 15)
3C1a	Biomass Burning in Forest Lands	Tier 1, 2 or 3	Data provider owning equal or greater than 100 Hectares of plantations	NO
3C1b	Biomass Burning in Croplands	NA	NA	NA
3C1c	Biomass Burning in Grasslands	NA	NA	NA
3C1d	Biomass Burning in All Other Land	NA	NA	NA
3C2	Liming	NA	NA	NA
3C3	Urea Application	NA	NA	NA
3C4	Direct N <sub>2</sub> O Emissions from Managed Soils	Tier 1, 2 or 3	Data provider owning equal or greater than 100 Hectares of plantations	NO
3C5	Indirect N <sub>2</sub> O Emissions from Managed Soils	Tier 1, 2 or 3	Data provider owning equal or greater than 100 Hectares of plantations	NO
3C6	Indirect N <sub>2</sub> O Emissions from Manure Management	NA	NA	NA
3C7	Rice Cultivations	NA	NA	NA
3C8	Other (please specify)	NA	NA	NA
3D	<b>Other</b>			NA
3D1	Harvested Wood Products	Tier 1, 2 or 3	HWP produced from timber harvested from forest owners registered for reporting ( see threshold defined in 3B1a and 3B1b)	NO
3D2	Other (please specify)	Tier 1, 2 or 3	NA	NO
4	<b>WASTE</b>			
4A	<b>Solid Waste Disposal</b>			
4A1	Managed Waste Disposal Sites	Tier 1 or 2	Receiving 5 tonnes per day or a total capacity of 25 000 tonnes	NO
4A2	Unmanaged Waste Disposal Sites	Tier 1 or 2	Receiving 5 tonnes per day or a total capacity of 25 000 tonnes	NO
4A3	Uncategorised Waste Disposal Sites	Tier 1 or 2	Receiving 5 tonnes per day or a total capacity of 25 000 tonnes	NO
4B	<b>Biological Treatment of Solid Waste</b>	NA	NA	NA
4C	<b>Incineration and Open Burning of Waste</b>			
4C0	Waste – Pyrolysis	Tier 2 or 3	100 kg/hour	YES
4C1	Waste Incineration	Tier 1 or 2	1 tonne per hour	NO
4C2	Open Burning of Waste	NA	NA	NO
4D	<b>Wastewater Treatment and Discharge</b>			
4D1	Domestic Wastewater Treatment and Discharge	Tier 1 or 2	2 million litres/day	NO
4D2	Industrial Wastewater Treatment and Discharge	Tier 1 or 2	1000 cubic metres per day	NO
4E	<b>Other (please specify)</b>	NA	NA	NA
5	<b>Other</b>			
5A	Indirect N <sub>2</sub> O Emissions from the Atmospheric Deposition of Nitrogen in NO <sub>x</sub> and NH <sub>3</sub>	NA	NA	NA
5B	<b>Other (please specify)</b>	NA	None	NA



## 6. Setting of reporting boundaries

### 6.1. Organisational Boundary

Section 8(1) of the Regulations state that the reporting boundary for each installation must be based on operational control. This means that data providers should account for 100% of the GHG emissions and/or removals from facilities over which they have operational control.

If the reporting boundary is subject to a change of ownership or the activity is to be discontinued, then the data provider must notify the competent authority in writing within 14 days of such transfer of ownership or discontinued activity as prescribed in the Regulation section 6(2).

### 6.2. Operational Boundary

The operational boundary, according to the GHG Protocol, defines the scope of direct and indirect emissions that fall within a company's established organizational boundary. A company has operational control over an operation if the former or one of its subsidiaries has the full authority to introduce and implement its operating policies at the operation.

The Regulation states in section 8(2) that direct Greenhouse Gas (GHG) emissions must be calculated including emissions generated during abnormal events that include start-up and shut-down and emergency situations (such as emergency pressure releases in gas networks) over the reporting period.

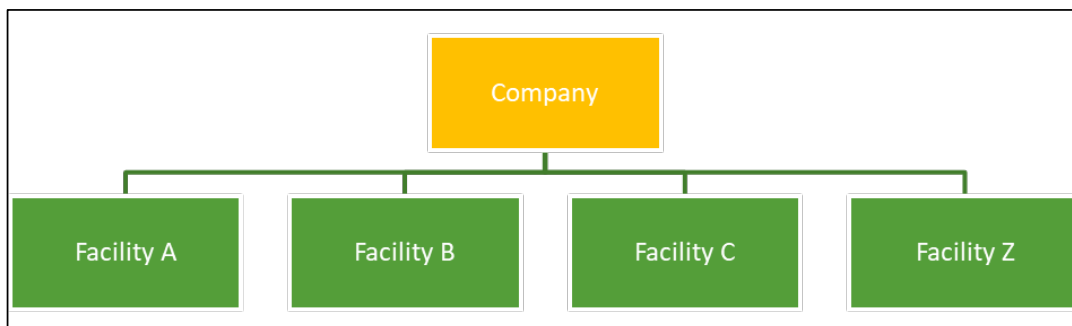

Figure 6:1: Diagram depicting operational control

## 7. Methodology

Data providers should select the methodology for the estimation of the GHG emissions from their operations in line with the 2006 IPCC Guidelines and the prescribed tier method post the transitional period for each activity as defines in annexure 1 of the NGERs.

The methodology of GHG emission estimation covers:

- selection of the calculation methods
- approach to and selection of activity data including keeping a record of monitoring plans<sup>6</sup>
- approach to and selection of emission factors

The 2006 IPCC National Inventories Guidelines follow a Tiered approach. This allows the data provider to follow an approach appropriate for the subsector in a specific period in time. A transitional arrangement allows data providers to report emissions using a lower tier method than prescribed in the Regulations, for a period of five years.

The Tiers are defined as follows:

- **Tier 1:** A bare minimum method using readily available statistical data on the intensity of processes (activity data) and default emission factors (Annexure 33). This method is the simplest method and has the highest level of uncertainty.
- **Tier 2:** similar to Tier 1 but uses technology or country specific emission factors. Tier 2 methods reduce the level of uncertainty. SAGERS will have pre-populated country specific emission factors for each reporting year. There are provisions within the NGERs for data providers to seek approval of country specific emission factor. If the emission factor is approved within the reporting cycle, the factor will only be available to the data provider who submitted it and will only be available for other users within SAGERS in the following reporting period
- **Tier 3:** Tier 3 is defined as any methodology more detailed than Tier 2 and might include amongst others, process models and direct measurements. Tier 3 methods have the lowest level of uncertainty. Some of the requirements for a Tier 3 approach may include:
  - Chemical analysis
  - Carbon content analysis
  - Carbon balances
  - Abatement equipment in use to determine any losses to the system
  - Literary evidence to support assumptions
  - The measured values of flows and chemical composition of the fuels used

For fuels, using tier 3 methodology, would require data providers to supply the following supporting information :

- Data should include fuel type and fuel composition,
- Type and size of the combustion unit, firing conditions, load, type of control technologies and maintenance level.
- Calculated Net Calorific Value (NCV) and documented methodology Equation
- Carbon content of the fuel

<sup>6</sup> Please refer to Section 2.1.1 as well as Annexure D of Validation and Verification Guidelines for guidance on Monitoring Plans.

- Moisture content
- Ash content
- Hydrogen and Oxygen based on selected firing method

The figure below illustrates the Tiered approach:

<sup>6</sup>Please refer to Section 2.1.1 as well as Annexure D of Validation and Verification Guidelines for guidance on Monitoring Plans.

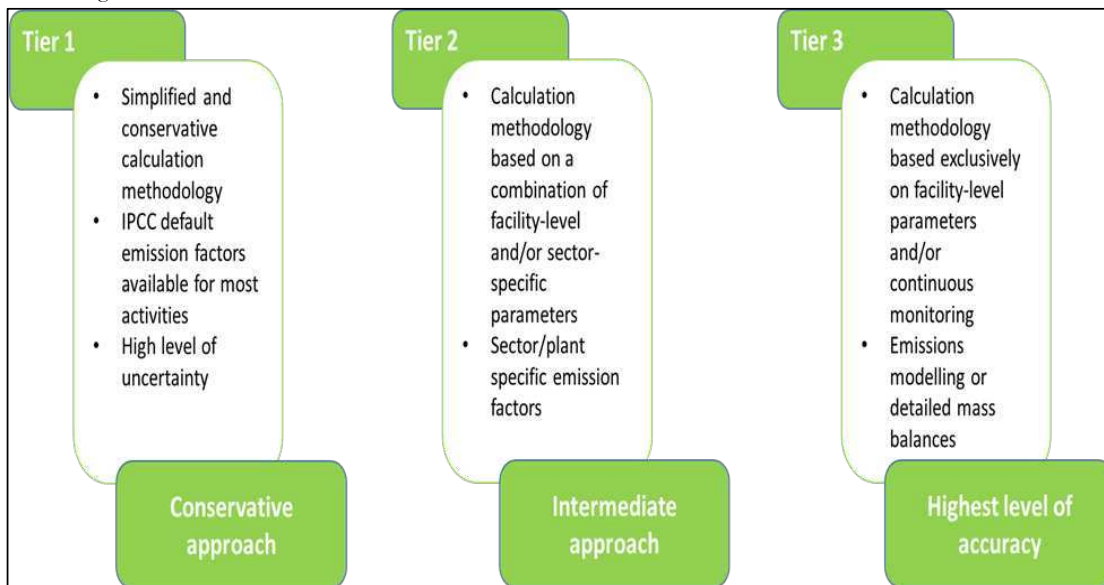

Figure 7.1: Tiers as per the 2006 IPCC Guidelines

The methods described in the 2006 IPCC Guidelines are based on the following five principles as contained in section 1.2, Volume 1, Chapter 1 of the 2006 IPCC Guidelines. These are:

- transparency
- completeness
- consistency
- comparability
- accuracy

The general methodology, which is relevant for all reporting subsectors mentioned above, combines activity data (the extent to which a human activity takes places) with the emission factor (coefficients which quantify the emissions or removals per unit of activity.). The basic equation for both tier 1 and tier 2 approaches is therefore:

$$Emissions = Activity\ Data \times Emission\ Factor$$

**7.1. IPCC Guidance on the use of Direct Measurements (tier 3) for quantification of GHG emissions.**

In some cases, especially on a Tier 3 level, direct measurement of GHG emissions may be required by the 2006 IPCC Guidelines. The regulations describe direct emission measurements as “a set of operations having the objective of determining the value of a quantity by means of periodic measurements, applying either measurements in the stack or extractive procedures with a measuring instrument located close to the stack” (DEA 2016, 5). The 2006 IPCC guidelines provide suggested measurement methodologies for all greenhouse gases as per the table below.

Table 7.1: Standard measurement methods for exhaust gases (IPCC 2006, Vol 1, 2.16)

GHG	Existing international standard methods	Other widely used standard methods <sup>4</sup>
CO <sub>2</sub>	ISO 12039:2001 Stationary source emissions - Determination of carbon monoxide, carbon dioxide and oxygen - Performance characteristics and calibration of an automated measuring method <sup>1</sup>  ISO 10396:2007 Stationary source emissions - Sampling for the automated determination of gas emission concentrations for permanently installed monitoring systems	US EPA Method 3 - Gas analysis for the determination of dry molecular weight  US EPA Method 3A - Determination of oxygen and carbon dioxide concentrations in emissions from stationary sources (instrumental analyser procedure)
CH <sub>4</sub>	ISO 25139:2011 Stationary source emissions – Manual method for the determination of the methane concentration using gas chromatography	US EPA Method 3C - Determination of carbon dioxide, methane, nitrogen and oxygen from stationary sources  Standard developed by ISO TC 264 - Air Quality
N <sub>2</sub> O	ISO 21258:2010 Stationary source emissions - Determination of the mass concentration of dinitrogen monoxide (N <sub>2</sub> O) - Reference method: Non-dispersive infrared method	Standard being developed by ISO TC 264 – Air Quality
Gas velocity	ISO 10780:1994 Air Quality - Stationary source emissions - Measurement of velocity and volume flow rate of gas streams in ducts. <i>S-Type pitot tube</i>  ISO 3966:1977 Measurement of fluid flow in closed conduits - velocity area method using Pitot static tubes. <sup>2</sup> <i>L-Type Pitot tube</i>  ISO 14164:1999 Stationary source emissions. Determination of the volume flow rate of gas streams in ducts -automated method. <i>Dynamic pressure method for continuous, in situ/cross duct, measurements</i>	US EPA Method 1 - Sample and velocity traverses for stationary sources  US EPA Method 1A - Sample and velocity traverses for stationary sources with small stacks or ducts  US EPA Method 2 - Determination of stack gas velocity and volumetric flow rate (Type S pitot tube) (or alternatively Methods 2F, 2G, 2H and CTM-041) <sup>5</sup>
General <sup>3</sup>	ISO/IEC 17025:2005 General requirements for the competence of testing and calibration laboratories  ISO 10012:2003 Measurement management systems - Requirements for measurement processes and measuring equipment	PrEN 15259:2005 Air Quality – Measurement of stationary source emissions - measurement strategy, measurement planning and reporting, and design of measurement sites  EN61207-1:1994 Expression of performance of gas analysers - Part 1 General
	<b>Standards under development</b>	
CO <sub>2</sub> , CH <sub>4</sub> , N <sub>2</sub> O	ISO/FDIS 20951 Soil Quality - Guidance on methods for measuring greenhouse gases	EN 14790 <sup>6</sup>

	(CO <sub>2</sub> , N <sub>2</sub> O, CH <sub>4</sub> ) and ammonia (NH <sub>3</sub> ) fluxes between soils and the atmosphere	US EPA Method 4 - Determination of moisture content in stack gases
PFC, SF <sub>6</sub> , HFC, FCs	None	(N.B. Where available sector specific methodologies are referenced in the sector specific volumes)
<p><sup>1</sup> This standard describes the performance characteristics, detection principles and the calibration procedures for automated measuring systems for the determination of carbon dioxide and other substances in the flue gases emissions from stationary sources. The reported concentration range of this standard is 6 - 62500 mg m<sup>-3</sup> with a measurement uncertainty of &lt;10 percent of the measured value.</p> <p><sup>2</sup> This standard has been withdrawn pending revision; nevertheless it is widely used in the absence of anything better.</p> <p><sup>3</sup> While these standards are not associated with a reference method for a specific greenhouse gas category, they have direct application to QC activities associated with estimations based on measured emission values.</p> <p><sup>4</sup> US EPA Methods, e.g., Method 1, 1A, 2, 3, etc., are EPA test methods that are available in Title 40 of the Code of Federal Regulations (CFR) Part 60, Appendices. These test methods are developed by the Office of Air Quality Planning and Standards in the Office of Air and Radiation. 40 CFR Part 60 is published each year by the Office of the Federal Register and is available from the U.S. Government Printing Office. Although the test methods generally do not change from year to year, users should check for the most recent version of 40 CFR Part 60, Appendices.</p> <p><sup>5</sup> Methods 2F and 2G correct the measured flow rates for angular (non-axial) flow. Method 2H (for circular stacks) and conditional test method CTM-041 (for rectangular stacks and ducts) are used to correct the measured flow rates for velocity decay near the stack wall, using a 'wall effects adjustment factor'.</p> <p><sup>6</sup> Water measurement is needed to correct measured gas volume to standard 'dry' conditions.</p>		

## 8. Time frames

Timelines in relation to specific aspects of the regulations are listed below. These timelines are important for data providers to consider when reporting emissions under the Regulations.

**Table 8:1: Important timelines that need to be considered when reporting under the Regulation**

Aspect of the Regulations	Timeline
Registration	30 days after the commencement of the Regulations or within 30 days after commencing such an activity once these regulations are in force.
Change in registration details	30 days from the date the data provider became aware of such change occurring.
Category A data provider submit GHG emissions and related data	31 March each year. Where the 31 March falls on a Saturday, Sunday or public holiday the submission deadline is the next working day.
Validation Process: Competent authority review and assessment of data submitted; Post submittal checks	60 days after the submission date.
Verification by Independent Verifiers	60 days after receiving the written instruction from the competent authority.
Record of information submitted to the SAGERS	A record of information submitted must be kept for five years.
Transitional arrangements	A data provider may, for a transitional period of up to five years from the date of commencement of these Regulations, apply lower tiers than those referred to in Annexure 1 to these Regulations, with tier 1 method being the minimum. The transitional period ends on 02 April 2022. Therefore, the 2023 reporting cycle will require compliance with Regulation 15 of the GHG Regulations.

## 9. Activity data

The 2006 IPCC Guidelines define activity data as: “Data on the magnitude of a human activity resulting in emissions or removals taking place during a given period. Data on energy use, metal production, land areas, management systems, lime and fertilizer use, and waste quantities are examples of activity data” (IPCC 2006, Glossary, G.2). This definition is also applied in the NGERs.

**Table 9:1: IPCC Source codes stipulated in NGERs Annexure 1 and their associated activity data needs for a tier1/2 IPCC methodology.**

IPCC Code	Name	Activity data required	Units
<b>1</b>	<b>ENERGY</b>		
<b>1A</b>	<b>Fuel Combustion Activities</b>		
<b>1A1</b>	Energy Industries	amount of fuel combusted/Consumed (Energy Unit)	Terajoule (TJ)
<b>1A1a</b>	Main Activity Electricity and Heat Production	amount of fuel combusted/Consumed (Energy Unit)	Terajoule (TJ)
<b>1A1b</b>	Petroleum Refining	amount of fuel combusted/Consumed (Energy Unit)	Terajoule (TJ)
<b>1A1c</b>	Manufacture of Solid Fuels and Other Energy Industries	amount of fuel combusted/Consumed (Energy Unit)	Terajoule (TJ)
<b>1A2</b>	<b>Manufacturing Industries and Construction</b>		
<b>1A2a</b>	Iron and Steel	amount of fuel combusted/Consumed (Energy Unit)	Terajoule (TJ)
<b>1A2b</b>	Non-Ferrous Metals	amount of fuel combusted/Consumed (Energy Unit)	Terajoule (TJ)
<b>1A2c</b>	Chemicals	amount of fuel combusted/Consumed (Energy Unit)	Terajoule (TJ)
<b>1A2d</b>	Pulp, Paper and Print	amount of fuel combusted/Consumed (Energy Unit)	Terajoule (TJ)
<b>1A2e</b>	Food Processing, Beverages and Tobacco	amount of fuel combusted/Consumed (Energy Unit)	Terajoule (TJ)
<b>1A2f</b>	Non-Metallic Minerals	amount of fuel combusted/Consumed (Energy Unit)	Terajoule (TJ)
<b>1A2g</b>	Transport Equipment	amount of fuel combusted/Consumed (Energy Unit)	Terajoule (TJ)
<b>1A2h</b>	Machinery	amount of fuel combusted/Consumed (Energy Unit)	Terajoule (TJ)
<b>1A2i</b>	Mining and Quarrying	amount of fuel combusted/Consumed (Energy Unit)	Terajoule (TJ)
<b>1A2j</b>	Wood and Wood Products	amount of fuel combusted/Consumed (Energy Unit)	Terajoule (TJ)
<b>1A2k</b>	Construction	amount of fuel combusted/Consumed (Energy Unit)	Terajoule (TJ)
<b>1A2l</b>	Textile and Leather	amount of fuel combusted/Consumed (Energy Unit)	Terajoule (TJ)
<b>1A2m</b>	Brick manufacturing:	amount of fuel combusted/Consumed (Energy Unit)	Terajoule (TJ)
<b>1A2n</b>	Manufacture of ceramic products by firing in particular roofing tiles, tiles, stoneware or porcelain	amount of fuel combusted/Consumed (Energy Unit)	Terajoule (TJ)
<b>1A3</b>	<b>Transport</b>		
<b>1A3a</b>	Civil Aviation	amount of fuel combusted/Consumed (Energy Unit)	Terajoule (TJ)
<b>1A3c</b>	Railways	amount of fuel combusted/Consumed (Energy Unit)	Terajoule (TJ)
<b>1A3d</b>	Water-borne Navigation	amount of fuel combusted/Consumed (Energy Unit)	Terajoule (TJ)
<b>1A4</b>	<b>Other Sectors</b>		
<b>1A4a</b>	Commercial/Institutional	amount of fuel combusted/Consumed (Energy Unit)	Terajoule (TJ)
<b>1A4b</b>	Residential	amount of fuel combusted/Consumed (Energy Unit)	Terajoule (TJ)
<b>1A4c</b>	Agriculture/Forestry/Fishing/Fish Farms	amount of fuel combusted/Consumed (Energy Unit)	Terajoule (TJ)
<b>1A5</b>	<b>Non-Specified</b>		
<b>1A5a</b>	Stationary	amount of fuel combusted/Consumed	Terajoule (TJ)

IPCC Code	Name	Activity data required	Units
(Energy Unit)			
<b>1B</b>	<b>Fugitive Emissions from Fuels</b>		
<b>1B1</b>	<b>Solid Fuels</b>		
1B1a	Coal Mining and Handling	<input type="checkbox"/> Amount of <input type="checkbox"/> Coal <input type="checkbox"/> Produced	tonne
1B1c	Solid Fuel Transformation	<input type="checkbox"/> Amount of solid fuel transformed (production and/or input material)	tonne
<b>1B2</b>	<b>Oil and Natural Gas</b>	<input type="checkbox"/>	
1B2a	Oil	<input type="checkbox"/> Amount of crude oil processed/transmitted/flared/vented, etc.	Cubic metres (m <sup>3</sup> )
1B2b	Natural Gas	<input type="checkbox"/> Amount of gas produced/transmitted/flared/vented, etc.	Cubic metres (m <sup>3</sup> )
1B3	Other Emissions from Energy Production	<input type="checkbox"/> Only tier 3 methodology is applicable	tonnes
<b>1C</b>	<b>Carbon Dioxide Transport and Storage</b>	<input type="checkbox"/> Only tier 3 methodology is applicable	tonnes
<b>1C1</b>	<b>Transport of CO<sub>2</sub></b>	<input type="checkbox"/>	
1C1a	Pipelines	<input type="checkbox"/> Only tier 3 methodology is applicable	tonnes
1C1b	Ships	<input type="checkbox"/> Only tier 3 methodology is applicable	tonnes
1C1c	Other (please specify)	<input type="checkbox"/> Only tier 3 methodology is applicable	tonnes
<b>1C2</b>	<b>Injection and Storage</b>	<input type="checkbox"/>	
1C2a	Injection	<input type="checkbox"/> Only tier 3 methodology is applicable	tonnes
1C2b	Storage	<input type="checkbox"/> Only tier 3 methodology is applicable	tonnes
1C3	Other	<input type="checkbox"/> Only tier 3 methodology is applicable	tonne
<b>2</b>	<b>INDUSTRIAL PROCESSES AND PRODUCT USE</b>		
<b>2A</b>	<b>Mineral Industry</b>		
2A1	Cement Production	<input type="checkbox"/> Individual type of cement produced <input type="checkbox"/> Mass of individual type of cement produced <input type="checkbox"/> Clinker fraction in cement <input type="checkbox"/> Imports for consumption of clinker <input type="checkbox"/> Export of clinker	tonne tonne tonne tonne tonne
2A2	Lime Production	<input type="checkbox"/> Type of lime produced <input type="checkbox"/> Mass of lime produced	tonne tonne
2A3	Glass Production	<input type="checkbox"/> Total glass production <input type="checkbox"/> Cullet Ratio	tonne dimensionless
<b>2A4</b>	<b>Other Process Uses of Carbonates</b>		
2A4a	Ceramics	<input type="checkbox"/> Mass of carbonate consumed <input type="checkbox"/> Ratio of limestone versus dolomite	tonne dimensionless
2A4b	Other uses for Soda Ash	<input type="checkbox"/> Mass of carbonate consumed <input type="checkbox"/> Type of Use	tonne tonne
2A4c	Non-Metallurgical Magnesia Production	<input type="checkbox"/> Type of use <input type="checkbox"/> Mass of carbonate consumed	tonne tonne
2A4d	Other (please specify)	<input type="checkbox"/> Type of use <input type="checkbox"/> Mass of carbonate consumed	tonne tonne
2A5	Other (please specify)	<input type="checkbox"/> Production/Consumption quantity	tonne
<b>2B</b>	<b>Chemical Industry</b>		
2B1	Ammonia Production	<input type="checkbox"/> Amount of Ammonia Produced <input type="checkbox"/> Amount of fuel consumption (e.g. natural gas) as feedstock	tonne Terajoule (TJ)
2B2	Nitric Acid Production	<input type="checkbox"/> Amount of Nitric Acid Produced	tonne



IPCC Code	Name	Activity data required	Units
2B3	Adipic Acid Production	<input type="checkbox"/> Amount of Adipic Acid Produced	tonne
2B4	Caprolactam, Glyoxal and Glyoxylic Acid Production	<input type="checkbox"/> Amount of Chemical Produced per type of chemical (i.e. Caprolactam, Glyoxal and Glyoxylic Acid)	tonne
2B5	Carbide Production	<input type="checkbox"/> Type of Carbide Produced (Silicone/Calcium) <input type="checkbox"/> Raw Material (Petroleum coke) Consumption	tonne
2B6	Titanium Dioxide Production	<input type="checkbox"/> Type of Production (Titanium, Synthetic, Rutile) <input type="checkbox"/> Amount of Production	tonne
2B7	Soda Ash Production	<input type="checkbox"/> Amount of Trona Utilised	tonne
2B8	Petrochemical and Carbon Black Production	<input type="checkbox"/> Production/Consumption quantity	tonne
2B8a	Methanol	<input type="checkbox"/> Type of Process <input type="checkbox"/> Amount of Methanol Produced	tonne
2B8b	Ethylene	<input type="checkbox"/> Type of Feedstock <input type="checkbox"/> Amount of Ethylene Produced	tonne
2B8c	Ethylene Dichloride and Vinyl Chloride Monomer	<input type="checkbox"/> Type of Process <input type="checkbox"/> Amount of Ethylene Dichloride and Vinyl Chloride Monomer Produced	tonne
2B8d	Ethylene Oxide	<input type="checkbox"/> Type of Process <input type="checkbox"/> Amount of Ethylene Oxide Produced	tonne
2B8e	Acrylonitrile	<input type="checkbox"/> Type of Process <input type="checkbox"/> Amount of Acrylonitrile Produced	tonne
2B8f	Carbon Black	<input type="checkbox"/> Type of Process <input type="checkbox"/> Amount of Carbon Black Produced <input type="checkbox"/> Amount of crude oil used as feedstock	tonne
2B8g	Hydrogen Production	Only tier 3 methodology is applicable	tonne
2B9	Fluorochemical Production		
2B9a	By-product Emissions	<input type="checkbox"/> Type of Process <input type="checkbox"/> Amount of HCFC-22 Produced	tonne
2B9b	Fugitive Emissions	<input type="checkbox"/> Fluorinated Compound Produced <input type="checkbox"/> Gas Emitted <input type="checkbox"/> Amount of Fluorinated Compound Produced	tonne
2B10	Other (Please specify)	<input type="checkbox"/> Production/Consumption quantity	tonne
2C	<b>Metal Industry</b>		
2C1	Iron and Steel Production	<input type="checkbox"/> Type of Steel Making Method <input type="checkbox"/> Amount of Steel or Iron Production <input type="checkbox"/> Amount of carbon-based materials used as feedstock	tonne
2C2	Ferroalloys Production	<input type="checkbox"/> Type of Ferroalloy <input type="checkbox"/> Amount of Ferroalloy Production <input type="checkbox"/> Amount of carbon-based materials used as feedstock	tonne
2C3	Aluminium Production	<input type="checkbox"/> Type of Technology <input type="checkbox"/> Amount of Aluminium Produced	tonne
2C4	Magnesium Production	<input type="checkbox"/> Raw Material Source <input type="checkbox"/> Amount of Primary	- tonne

IPCC Code	Name	Activity data required	Units
		Magnesium Production	
2C5	Lead Production	<input type="checkbox"/> Source of Furnace Type <input type="checkbox"/> Amount of Lead Production <input type="checkbox"/> Amount of carbon-based materials used as feedstock	- tonne
2C6	Zinc Production	<input type="checkbox"/> Type of Process <input type="checkbox"/> Amount of Zinc Production	- tonne
<b>3</b>	<b>AGRICULTURE, FORESTRY, AND OTHER LAND USE</b>		
3A2i	Poultry	<input type="checkbox"/> Number of places for poultry	Number of head of livestock species
<b>3B</b>	<b>Land</b>		
<b>3B1</b>	<b>Forest Land</b>		
3B1a	Forest land Remaining Forest Land	<input type="checkbox"/> Initial Land-Use Area <input type="checkbox"/> Final Land-Use Area	ha
3B1b	Land Converted to Forest Land	<input type="checkbox"/> Initial Land-Use Area <input type="checkbox"/> Final Land-Use Area	ha
3C1a	Biomass Burning of Forest Lands	<input type="checkbox"/> Initial Land-Use Area <input type="checkbox"/> Final Land-Use Area	ha
3C4	Direct N <sub>2</sub> O Emissions from Managed Soils	<input type="checkbox"/> Land Area	ha
3C5	Indirect N <sub>2</sub> O Emissions from Managed Soils	<input type="checkbox"/> Land Area	ha
3D1	Harvested Wood Products	<input type="checkbox"/> Land Area	ha
<b>4</b>	<b>WASTE</b>		
4A	Solid Waste Disposal	<input type="checkbox"/> Total Municipal Solid Waste Generated <input type="checkbox"/> Percentage MSW sent to Solid Waste Disposal Sites	Gigagrams (Gg) -
4A1	Managed Waste Disposal Sites		
4A2	Unmanaged Waste Disposal Sites		
4A3	Uncategorised Waste Disposal Sites		
4C	Incineration and Open Burning of Waste		
4C1	Waste Incineration	<input type="checkbox"/> Waste Category <input type="checkbox"/> Type of incineration technology <input type="checkbox"/> Total Amount of Waste Incinerated (Wet weight)	- - Gigagrams (Gg)
4D	Wastewater Treatment and Discharge		
4D1	Domestic Wastewater Treatment and Discharge	<input type="checkbox"/> City/Region <input type="checkbox"/> Population <input type="checkbox"/> Degradable organic component (BOD) <input type="checkbox"/> Correction factor for industrial BOD discharged in sewers	- - Kg BOD/Cap.yr -
4D2	Industrial Wastewater Treatment and Discharge	<input type="checkbox"/> Industry Sector <input type="checkbox"/> Total Industry Product <input type="checkbox"/> Wastewater generated <input type="checkbox"/> Chemical Oxygen Demand (CODi)	tonnes/year (t/yr) cubic meters/year (m <sup>3</sup> /t) kg COD/m <sup>3</sup>

## 10. Emission Factors

Data providers should exercise care in the selection of emission factors. In principle, emission factors from the highest available Tier should be used in estimating GHG emissions.

The Tier 1 methodologies allow for the use of default emission factors readily available in the 2006 IPCC Guidelines. Tier 2 methodologies require more appropriate emission factors such as country specific emission factors (for example those developed by sectors or through the Greenhouse Gas Improvement Programme). Tier 3 methodologies require facility or technology specific parameters that describe carbon inputs and process conditions.

Where appropriate country specific emission factors are listed in the relevant Annexures. A list of relevant IPCC default emission factors is available in Annexures A, B and C. South African country specific emission factors should be referred to first and where there is no South African specific emission factor one should refer to the IPCC default emission factors. This is provided that the country-specific emissions factors have been subjected to (1) an independent review process and (2) have received approval from the competent authority. Hence, it is good practice for emitting sectors/companies to involve the competent authority from the beginning of the process to develop country-specific emission factors. That will enable the competent authority to evaluate whether the emission factors are being developed in line with the requirements of the regulations as per section 10.1 below.

### 10.1. Revision of Emission Factors

Emission factors can be revised, or new emission factors can be proposed. Any new emission factors need to be submitted to the competent authority for review as per section 10(2) of the Regulations.

Request for review and submission of a new emission factor to the competent authority shall be done using the Annexure 4 template of the NGERs reproduced as Table 10.1.

**Table 10.1: Template to be used by data providers for the process of adopting a new emission factor (DEA 2016, 22)**

<b>REQUEST FOR REVIEW OF EMISSION FACTOR</b>	
<b>Administrative information</b>	
Data Provider	
Data Provider - location of measurement study	
Data Provider Contact	
Date Calculated	
Date submitted to competent authority by Data provider	
Technical report/scientific paper attached?	
<b>Technical information</b>	
Greenhouse gas	
Applicability – relevant IPCC Code	
Applicability of Emission Factor – Plant Specific/Sector-specific/Country-specific	
Relevant IPCC Source-Category in terms of 2006 IPCC or later Guidelines	
<b>Parameter</b>	Type / name

REQUEST FOR REVIEW OF EMISSION FACTOR		
	Value	
	Unit	
	95% confidence interval	
Method	Technique/standard	
	Date(s) of measurement	
	External QA/QC	
	Comment's data provider	
	Comment's others (e.g. independent verifier)	

### 10.2. Criteria to be used in the evaluation by the Competent Authority

The evaluation of the submitted emission factors should ensure that the resultant emission estimates are neither over- nor under-estimated as far as can be judged and that uncertainties are reduced as far as practicable. To achieve this, a proposed emission factor or other parameter should:

- Be in line with the fundamental principles and approaches of the *2006 IPCC Guidelines for National Greenhouse Gas Inventories*.
- Be accompanied by documentation describing the conditions of its derivation and information regarding the level of uncertainty, preferably quantified but at a minimum with some qualitative indicators attached to it.
- Be unbiased and as accurate as possible.
- Contribute to the Emission Factor Library (EFL) of the National Atmospheric Emission Inventory System (NAEIS) by adding a value for a source not already covered or by providing a different value or an identical but independent value for an existing emission factor or parameter type. The technical information in the "properties fields" should provide the information needed to differentiate between the alternative values for emission factors or parameters for a particular source.

To meet these standards, the proposed emission factor or other parameter should be robust, applicable and documented. Each of these is briefly discussed below.

### 10.3. Robustness of emission factor

A robust emission factor or other parameter is one that, within the accepted uncertainty, is unlikely to change if the original measurement programme or modelling activity were to be repeated. Specific issues concerning robustness are as follows:

- Are the measurement techniques including raw data validated and/or verified?
- Are the modelling techniques including supporting data validated and/or verified?
- Is the conversion (if any) from model assumptions or measurement conditions to annual or other forms of emission factors or other parameters sufficiently explained and justified?
- Is an uncertainty assessment on the emission factor or other parameter presented?

### 10.4. Applicability of the emission factor

An applicable emission factor or other parameter is one that matches either a specific IPCC source/sink category or subcategory, or another well-defined source category that can be used in a national inventory compilation. An emission factor is applicable if the source and its mix of technology, operating and environmental conditions and abatement and control technologies under which the emission factor was measured or modelled are clear and allow the user to see how it can be applied.

#### **10.5. Documentation of emission factor**

For emission factors or other parameters to be transparent, access information to the original technical reference must be provided to evaluate the robustness and applicability as described above. This can preferably be done by providing sufficient information through a scientific or technical publication in an internationally available journal or a report or book with an ISBN number. For those emission factors or other parameters where this is not available, the data provider can provide the information required to enable a judgement on its robustness and applicability as described above through technical documentation, or by sufficient information in the proposal document fields of the database to satisfy the acceptance requirements.

The information provided to the competent authority should be detailed and comprehensive enough so that users may be able to evaluate the applicability to a national GHG inventory. Crucial elements are an accurate source definition and proper information on the type and extent of validation and on known applications to date.

## 11. Quality Assurance/Quality Control and Verification requirements

### 11.1. Management Systems

The 2006 IPCC Guidelines recommend that the data provider integrates its emissions QA/QC procedures with **in-house quality management systems.**

Typically, a QA/QC plan could have a list of *data quality objectives*. For further information please refer to Volume 1, Chapter 6 of the 2006 IPCC Guidelines. Such a list could include:

- timeliness
- completeness
- consistency (internal consistency as well as time series consistency)
- comparability
- accuracy
- transparency
- improvement

### 11.2. Verification and Validation

Section 11 of the Regulations state that:

The competent authority must validate, in accordance with the assessment procedures in the latest version of the Technical Guidelines for Validation and Verification of Greenhouse Gas Emissions, the data submitted by a data provider within 60 days after submission date. This assessment may include

- a) methods defined in the latest version of the Methodological Guidelines for Quantification of Greenhouse Gas Emissions. Technical Guidelines for Validation and Verification of Greenhouse Gas Emissions.
- b) Earlier submissions
- c) Submissions from similar facilities; and
- d) Other independent data

As per Figure 11:1 the validation checks by the Competent Authority will determine a series of decisions that can lead to the need to either:

- (a) Accept the submitted report.
- (b) Institute an inspection of facility/facilities by the Competent Authority
- (c) Refer the report for independent verification

If the validation results demonstrate that there is potentially a high risk of misstatement, the Competent Authority **may request the facility/facilities to undergo independent verification without starting with on-site inspection.** If even after the independent verification, the queries raised by the Competent Authority are not addressed, the report will not be approved, and it will be referred to compliance enforcement as per NEMA.

The competence of independent verifiers as well as principles to follow are addressed within the Technical Guidelines for Validation and Verification of Greenhouse Gas Emissions. It is critical that independent verifiers are independent of the data providers operations to ensure objectivity and impartiality in the verification process. Verifiers need to meet the following principles:

- impartiality
- competence
- factual approach to decision making
- openness
- confidentiality

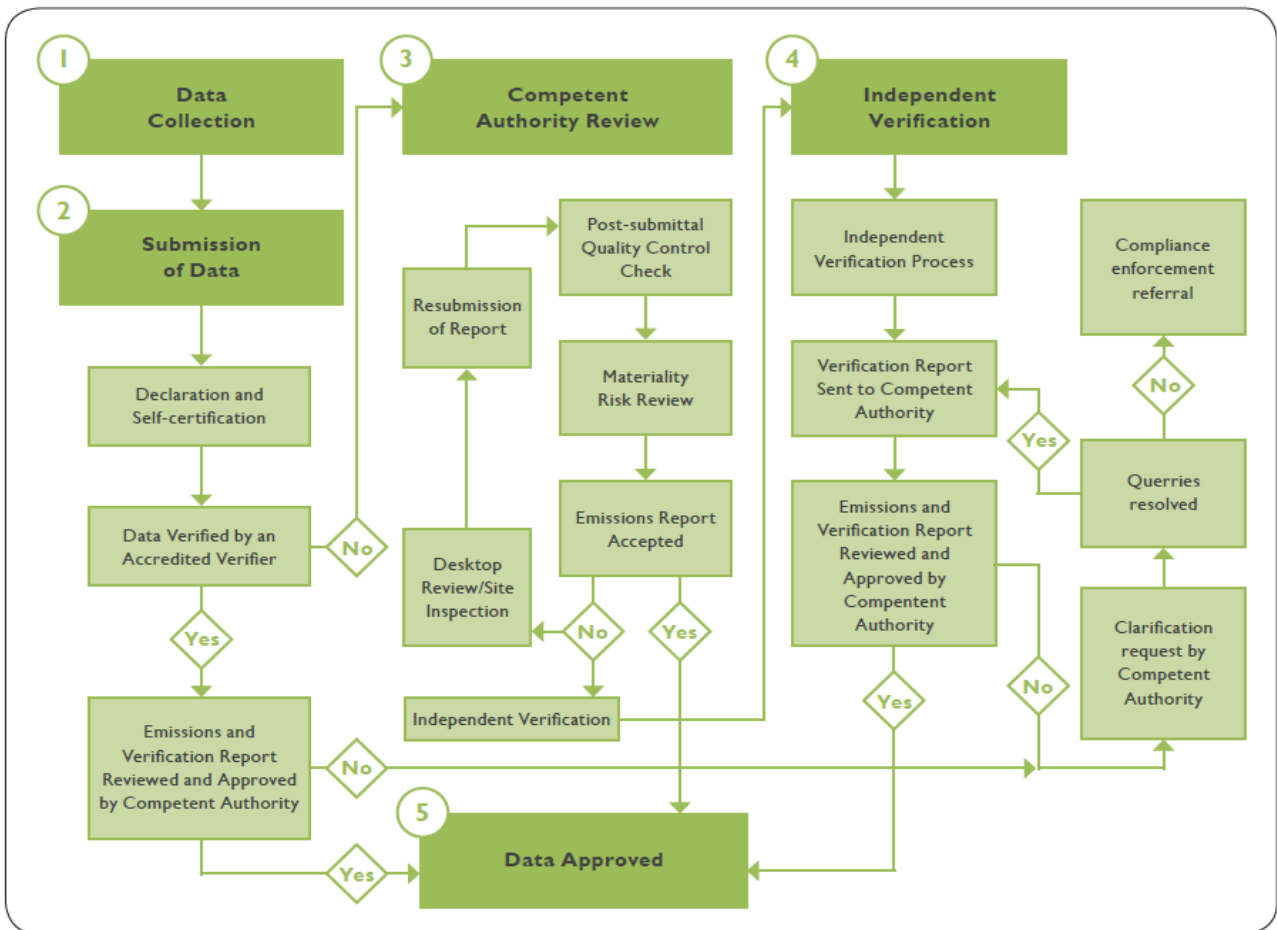

Figure 11:1: Process flow summary of the NGERs Verification Programme



### 11.3. Administration and record keeping by data providers

Regulation 13(2) of the NGERs state that data providers must keep a record of the information that is submitted to NAEIS (SAGERS) for five years (DEA 2016, 12) and this will satisfy the monitoring plans as per Section 2.1.1 and Annexure D of the Technical Guidelines for Validation and Verification of Greenhouse Gas Emissions, as needed for verification process in case a data provider is asked to undergo verification. If requested the records should be made available for inspection by the competent authority. In this context, the following requirements must be met:

- Relevant GHG inventory records, including activity data, emission factors and calculation methods must be kept. Relevant documentation could include emissions or flow metering records, purchase receipts, delivery receipts, production reports, carbon content laboratory results and stock inventory documentation.
- A record of information on management activities should be kept allowing the data provider to explain the management process behind data administration and record keeping in the company.

## Methodological guidance

## 12. Stationary Combustion

This section details the methods and data necessary to estimate emissions from stationary combustion. A distinction is made between stationary combustion in energy industries (1.A.1), manufacturing industries and construction (1.A.2) and other sectors (1.A.4). Although these distinct subsectors are intended to include all stationary combustion, an additional category is available in sector 1.A.5 for any emissions that cannot be allocated to one of the other subcategories.

Category 1.A<sup>7</sup> of the energy sector involves emissions from combustion of fossil fuels, which can be in liquid, gaseous or solid form. The amount of emissions from a particular fuel mainly depends on the carbon content of the fuel. In addition to CO<sub>2</sub> emissions from fuel combustion, other major associated GHG emissions include CH<sub>4</sub>, N<sub>2</sub>O, CO, SO<sub>2</sub> and non-methane volatile organic compounds (NMVOC). Associated emissions of CH<sub>4</sub> and N<sub>2</sub>O are usually small, depending on technology and conditions of combustion.

Sources of emissions that should be included under Category 1.A (stationary combustion) include the following:

- 1.A1 Energy industries
  - o 1A1a Electricity and heat production
  - o 1A1b Petroleum refining
  - o 1A1c Manufacture of solid fuels and other energy industries
- 1.A2 Manufacturing industries and construction<sup>8</sup>
  - o 1A2a Iron and steel (emissions not defined as process emissions as per Volume 3, Chapter 4 of IPCC 2006 guidelines and Section 37 of this document). This category includes other industries that produced ferrous metals such as Ferroalloy production.
  - o 1A2b Non-ferrous metals (aluminium, magnesium, lead, zinc, other non-iron metals)
  - o 1A2c Chemicals
  - o 1A2d Pulp, paper and print
  - o 1A2e Food processing, beverages and tobacco
  - o 1A2f Non-metallic minerals (cement, lime, glass, soda ash, magnesia, other uses of carbonates)
  - o 1A2h Machinery

<sup>7</sup> Please note that for reporting purposes under the NGERs, reporting on categories 1A3b (road transportation) and 1A3e ii (Off-road) is voluntary as these activities are excluded from mandatory reporting. This means companies are not expected to report emissions associated with their vehicle use and on-site mobile equipment.

<sup>8</sup> Emissions from other producers or CHP facilities should be assigned to the sector where they were generated and not under 1A1aii (Combined Heat and Power Generation). If CHP is used for internal purpose in any of the facilities operating source categories listed in 1A2 (Manufacturing Industries and Construction) then the emissions from CHP should be reported under 1A2.

- o 1A2i Mining and quarrying
- o 1A2j Wood and wood products
- o 1A2k Construction
- o 1A2l Textile and leather
- o 1A2m Brick Manufacturing (please refer to Section 29 for guidance on process emissions)
- o 1A2n Ceramics (please refer to Section 29 for guidance on process emissions)
  
- 1.A4 Other sectors
  - o 1A4a Commercial/institutional/public
  - o 1A4b Residential
  - o 1A4c Agriculture/forestry/fishing/fish farms
  
- 1.A5 Non-specified
  - o 1A5a Stationary

If data providers have back-up generators installed to meet energy needs in any of the above activities, those stand-by generators must be declared within SAGERS if the data provider is already meeting the determined threshold in an applicable activity or when all the standby generators meet the reporting thresholds as determined by NGERs. The emissions related to fuel used in those generators must also be reported. These generators must be registered under facilities where they are installed. In case of application in commercial buildings, the standby generators must be aggregated and registered as one facility within SAGERS and the detailed generators at different offices can be attached using Annexure 5 of the (NGERs) as shown in Figure 12:1 below.

Registration:		Details			Comments
Data Provider Name:					
Data Provider ID:					
Physical Address of the data provider:					
Contact Person:					
Relevant IPCC code					
Total installed capacity of standby generators					
Generator types:	<b>Generator Description</b>	<b>Physical address of the generator</b>	<b>Number of back-up generators</b>	<b>Total capacity (kVA)</b>	<b>Total equivalent in (MW) thermal</b>
	<b>Generator Type 1<sup>10</sup></b>				
	<b>Generator Type 2</b>				
	<b>Generator Type 3</b>				
	<b>Generator type 4</b>				
	<b>Add more rows if applicable<sup>11</sup></b>				

Additional rows should be added to the table above to accommodate registration of additional standby generators as contemplated in Regulation 5.

Figure 12:1: Annexure 5: Registration of Standby Generators

If conducting fishing, please note that 1A4c includes the reporting of GHG emissions for stationary application related to fishing operations. **The mobile part of fishing is reported under 1A3dii.** This arrangement is specific to South Africa and deviates from 2006 IPCC Guidelines.

Annexure F provides the definitions of the IPCC source categories listed above.

This section covers the following IPCC sectors detailed in the table below:

**Table 12:1 IPCC sectors covered by stationary combustion**

Sector	Relevant IPCC code/s	Definition	Relevant IPCC Gases	Tier	Methodology reference	Transitional arrangements
Stationary combustion (1A)	1A1, 1A2, 1A4, 1A5,	All stationary combustion related fuel use.	CO <sub>2</sub>	2 or 3	Chapter 12	Yes
			CH <sub>4</sub>	1, 2 or 3	Chapter 12	No
			N <sub>2</sub> O	1, 2 or 3	Chapter 12	No

### 12.1. Methodology

Under the 2006 IPCC Guidelines emissions for stationary combustion can be estimated using one of the following three tiers.

#### Method 1 – IPCC Tier 1 methodology

Using Tier 1 approach requires the following:

- i. Data on the amount of fuel combusted
- ii. A default emission factor for CO<sub>2</sub>, CH<sub>4</sub> and N<sub>2</sub>O

Estimates of emissions from the combustion of individual fuel types are made by multiplying an activity data item (physical quantity of fuel combusted) by a fuel-specific energy content factor (see Annexure D for net-calorific values) and a fuel-specific emission factor (see annexure A for emission factors) for each relevant greenhouse gas. The list of South African fuels for which emissions must be calculated is given in Annexures A and D.

$$(\text{Emissions})_{ij} = Q_i \times EC_i \times EF_{ij} / 1000$$

Where:

$E_{ij}$  the emissions of gas type (j) in tonnes, being carbon dioxide, methane or nitrous oxide, released from the combustion of fuel type (i)

$Q_i$  is the quantity of fuel type in tonnes or litres for liquids or cubic metres for gases (except LPG)<sup>9</sup>(i)

$EC_i$  is the calorific value of the type of fuel (conversion factor) in Terajoule/tonne. Net calorific values should be used and are given in Annexure D

$EF_{ij}$  is the emission factor for each gas type (j) released during the year measured in mass units (kg) per Terajoule (TJ) of fuel type (i) (Annexure A)

A factor of 1000 (to convert from kilograms to tonnes of greenhouse gas)

While small oxidation variations may be known for different types of fuel, a general oxidation factor of 1 is assumed for all combustion activities.

### Method 2 – IPCC Tier 2 methodology

The Tier 2 method of estimating energy emissions from fuel combustion uses the same approach as Tier 1, except that in the Tier 2 method country-specific emission factors are used in place of the default factors. The following is required when using Tier 2;

- i. Data on the amount of fuel combusted
- ii. A country or regional specific emission factor for the source category and fuel for each gas.

When country specific emission factors are used it is good practice to document how the emission factors were derived.

### Method 3 – IPCC Tier 3 methodology

In using Tier 3 methods for energy emissions, direct measurements and data at individual plant level are used where appropriate. Application of a Tier 3 approach requires the following;

- i. Data on the amount of fuel combusted for each relevant technology (fuel type used, combustion technology, operating conditions, control technology, and maintenance and age of the equipment) or any other agreed periodic period of measurement concentrations data into GHG emissions and (2) to use fuel consumption data and default and or country-specific emission factors for verification of the CEMS GHG quantification approach.
- ii. Carbon content of fuel
- iii. A resulting specific emission factor for each technology (fuel type used, combustion technology, operating conditions, control technology, oxidation factor, and maintenance and age of the equipment) will therefore result.

<sup>9</sup> Liquefied Petroleum Gas (LPG) can be reported in tonnes or litres not cubic metres

The Tier 3 approach may involve the use of Continuous Emissions Monitoring (CEM) of flue gases, which in most cases involves comparatively high cost. If a plant has installed monitors for measurement of other pollutants such as SO<sub>2</sub> or NO<sub>x</sub>, continuous CO<sub>2</sub> monitoring may be easier. Please see Section 7 for guidance on the recommended measurement techniques for CO<sub>2</sub>, CH<sub>4</sub> and N<sub>2</sub>O.

It should be noted that using a Tier 3 approach to estimate emissions of CO<sub>2</sub> is often unnecessary because emissions of CO<sub>2</sub> do not depend on the combustion technology.

### 12.2. Activity Data

Activity data for stationary combustion is based on the amounts of fuel consumed in the operation and can often be derived from fuel invoices. Fuels received or fuels purchased by data providers in most cases can be an indication of fuels consumed. Carbon dioxide emissions can be calculated from fuel consumption data and the carbon contents of fuels, taking into account the fraction of carbon oxidised.

For additional guidance on stationary combustion activity data and uncertainty analysis please refer to the 2006 IPCC Guidelines Volume 2 Chapter 2.

Note that CO<sub>2</sub> emissions from the use of biomass, biofuels and biogas for electricity generation should be reported but excluded from emission totals.

### 12.3. Default Emission Factors and Net Calorific Values

A list of default emission factors can be found in Annexure A and can be used under the Tier 1 approach. In cases where data providers have access to more accurate country/fuel specific emission factors, these emission factors should be submitted to the competent authority for review as per regulation 10(1) and 10(2) of the NGERs (DEA 2016, 10). Country specific emission factors can be used under the Tier 2 approach.

Default calorific values of fossil fuels for South Africa can be found in Annexure D.

### 13. Public Electricity Generation

Electricity generation involves the conversion of fossil fuels (coal, oil, gas etc.) into electrical energy. Only facilities with a total thermal input generation capacity exceeding 10 MW are required to report according to the threshold set in the Regulations.

#### 13.1. IPCC Classification

The table below details the relationship between direct emission sources and the corresponding IPCC source categories for reporting under the National GHG Emissions Reporting Regulations.

Table 13.1: IPCC emission sources for Electricity Generation

Sector	Relevant IPCC code/s	Definition	Relevant IPCC gases	Tier	Methodology reference	Transitional arrangements (Regulation 15)
Electricity generation <sup>10</sup>	1A1ai	Comprises emissions from all fuel use for electricity generation from main activity producers except those from combined heat and power plants.	CO <sub>2</sub> <sup>11</sup>	2 or 3	Section 12	Yes
			CH <sub>4</sub>	1, 2 or 3	Section 12	No
			N <sub>2</sub> O	1, 2 or 3	Section 12	No
	2G1	Electrical equipment is used in the transmission and distribution of electricity above 1 kV. SF <sub>6</sub> is used in gas-insulated switchgear (GIS), gas circuit breakers (GCB), gas-insulated transformers (GIT), gas-insulated lines (GIL), outdoor gas-insulated instrument transformers, reclosers, switches, ring main units and other equipment	SF <sub>6</sub>	1,2 or 3	Section 44	NA

<sup>10</sup> Electricity generation for own internal use shall be reported under 1A2 and not under 1A1ai. For example, electricity generated from by-product gases in an iron and steel plant for own internal use should be reported under 1A2a

<sup>11</sup> Note that CO<sub>2</sub> emissions from the use of biomass, biofuels and biogas for electricity generation should be reported but excluded from emission totals.



Please note that the table above details the sectors that should be covered as a minimum. If there are other emission sources, under control of the data provider, that still need to be reported please report them under the relevant categories as listed in Section 5 of this document.

### 13.2. Methodology

CO<sub>2</sub> emissions from electricity generation is a key category, therefore a Tier 2 or Tier 3 approach should be followed, with data requirements as detailed in Section 7. Please refer to Stationary Combustion in Section 12 for guidance on how to calculate emissions from electricity production. Emissions factors for different fuels used in stationary combustion can be sourced from Annexure A.

The schematic below explains the emissions process flow involved in electricity generation.

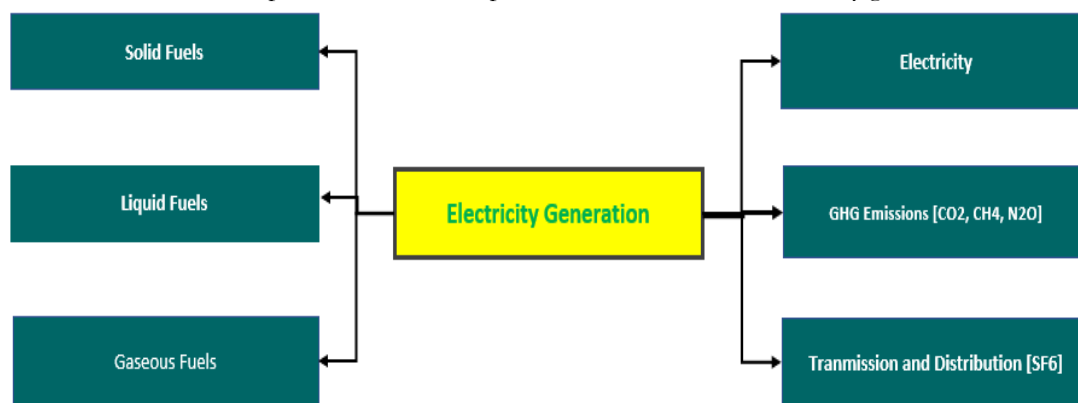

Figure 13:1 : Process flow for Electricity Generation

### 13.3. Activity Data

Activity data on the amount of fuel combusted can be based on purchase receipts, delivery receipts, production reports, carbon content lab results or stock inventory documentation.

### 13.4. Emission Factors

For emission factors please refer to Annexure A and for South African specific net calorific values (NCVs) please refer to Annexure D. Supporting documentation demonstrating how NCV values are derived shall be submitted if different from those listed in Annexure D. In cases where the data provider gets the net calorific values specified according to the Department of Mineral Resources and Energy's (DMRE) Regulations Regarding Petroleum Products Specifications and Standards of 2006<sup>12</sup>, the data provider must supply the details given by the fuel supplier in any form given.

<sup>12</sup> [http://www.energy.gov.za/files/policies/regulations\\_petroleumproducts\\_standards\\_2006.pdf](http://www.energy.gov.za/files/policies/regulations_petroleumproducts_standards_2006.pdf)

## 14. Combined Heat and Power

Combined heat and power generation (CHP) is an efficient and clean approach to generating electric or mechanical power and useful thermal energy from a single fuel source.

This section provides the details and data required to estimate emissions associated with CHP processes in terms of IPCC category 1A1aii (Combined Heat and Power Generation).

Emissions from other producers or CHP facilities should be assigned to the sector where they were generated and not under 1A1aii (Combined Heat and Power Generation). If CHP is used for internal purpose in any of the facilities operating source categories listed in 1A2 (Manufacturing Industries and Construction) then the emissions from CHP should be reported under 1A2.

### 14.1. IPCC Classification

The association between the direct emissions sources and the IPCC source categories for reporting under the National GHG Reporting Regulations is presented in table below.

**Table 14:1: IPCC classification of emissions for combined heat and power**

Sector	Relevant IPCC code/s	Definition	Relevant IPCC Gases	Tier	Methodology reference	Transitional arrangements
Combined heat and power	1A1aii	Emissions from production of both heat and electrical power from main activity producers for sale to the public at a single CHP facility.	CO <sub>2</sub>	2 or 3	Section 12	Yes
			CH <sub>4</sub>	1, 2 or 3	Section 12	No
			N <sub>2</sub> O	1, 2 or 3	Section 12	No

Please note that the table above details the source-category that should be covered as a minimum. If there are other emission sources, under control of the data provider, that still need to be reported please report them under the relevant categories as listed in Section 5 of this document.

Figure 14.1 presents a schematic representation of emission flow associated with the CHP generation process.

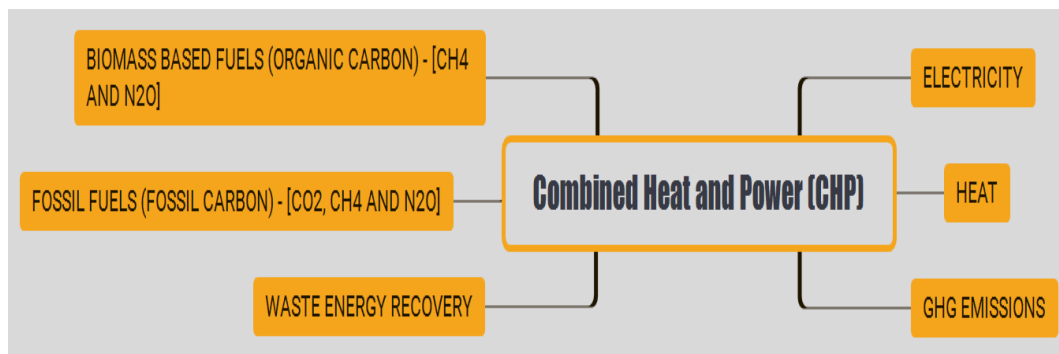

Figure 14:1: Process flow for Combined Heat and Power generation (CHP)

#### 14.2. Methodology

For guidance on calculating emissions from combined heat and power generation, please refer to Annexure A stationary combustion.

#### 14.3. Activity Data

The activity data required to determine the amount of emissions generated during the CHP generation process includes:

- the quantity of carbonaceous fuel used (tier 1 or Tier 2)
- continuous emissions measurements (CEM) if available (tier 3)

#### 14.4. Emission Factors

The emission factor used to determine the GHG emissions could be one of the following:

- a country specific emission factor for the source category and respective carbonaceous fuel source combusted (Tier 2)
- plant specific data on CO<sub>2</sub> emissions (Tier 3)

For default IPCC emission factors please refer to Annexure A and for South African specific calorific values please refer to Annexure D.

## 15. Charcoal Production

Combustion emissions are emitted from fuel use during the production of charcoal. Only direct emissions from the data provider should be reported, as per the Regulations.

### 15.1. IPCC Classification

Stationary combustion emissions from charcoal production should be classified and reported under source category 1.A.1.c “Manufacture of Solid Fuels and Other Energy Industries” of the 2006 IPCC Guidelines. Emissions from own on-site fuel use should be included in this category as well as combustion for the generation of electricity and heat for own use.

The table below details the relationship between direct emission sources and the IPCC source categories for reporting under the National GHG Reporting Regulations.

Table 15:1 IPCC emission sources associated with Charcoal Production

Sector	Relevant IPCC Code/s	Category Description	Relevant IPCC Gases	Methodology to be used	Methodology reference	Transitional Arrangements (Regulation 18)
Charcoal production	1A1c	Combustion emissions from fuel use during the manufacture of secondary and tertiary products from solid fuels including production of charcoal. Emissions from own on-site fuel use should be included. Also includes combustion for the generation of electricity and heat for own use in these industries.	CO <sub>2</sub>	Tier 2 or 3	Section 12	Yes
			CH <sub>4</sub>	Tier 1	Section 12	No
			N <sub>2</sub> O	Tier 1	Section 12	No
	1B1cii	Fugitive emissions during the production of Charcoal	CO <sub>2</sub>	Tier 1	Section 15	Yes
			CH <sub>4</sub>	Tier 1	Section 15	No
			N <sub>2</sub> O	Tier 1	Section 15	No

Please note that the table above details the sectors that should be covered as a minimum. If there are other emission sources, under control of the data provider, that still need to be reported please report them under the relevant categories as listed in Section 5 of this document.

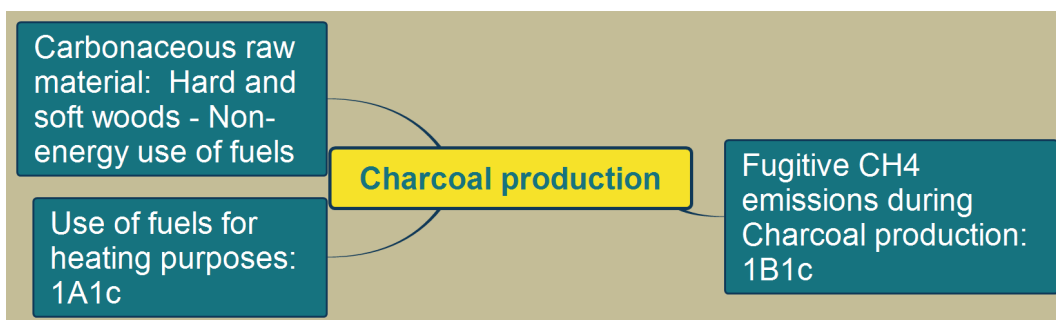

Figure 15:1: Process flow for Charcoal Production

### 15.2. Methodology

There are various methodologies, which could be followed to quantify emissions:

- Activity data should be multiplied with a specific and relevant emission factor which can either be a default (Tier 1) emission factor or country specific emission factor (Tier 2).
- A company could carry out continuous emissions monitoring to measure the quantity of GHG emissions produced (Tier 3).

### 15.3. Activity Data

Activity data could be the quantity of carbonaceous raw material input into the kiln.

### 15.4. Emission Factors

The 2006 IPCC Guidelines do not provide an emission factor for charcoal production, for this reason the 1996 IPCC Guidelines are referenced (IPCC 1996) when the data available is the amount of fuel wood input for charcoal production.

Table 15:2: Emission factors for fugitive CH<sub>4</sub> emissions from charcoal production as detailed in Volume 3, Energy, Table 1-14 from the 1996 IPCC Guidelines (IPCC 1996, 1.46)

Source	Emission Factor
Fuel wood input	300 kg CH <sub>4</sub> /TJ of wood input

When data regarding the amount of charcoal produced is available, emission factors from the 2019 IPCC Refinements should be used.

Table 15:3: Emission factors for fugitive emissions from charcoal production as detailed in Volume 2, Energy, Table 4.3.3 from the 2019 IPCC Refinements (IPCC 2019)

Gas	Emission Factor (tonne GHG/ tonne of charcoal produced)
CO <sub>2</sub>	1.5
CH <sub>4</sub>	0.0403
N <sub>2</sub> O	0.00008

## 16. Biochar Production

Stationary combustion emissions from bio production should be classified and reported under source category 1.A.1.c “Manufacture of Solid Fuels and Other Energy Industries” of the 2006 IPCC Guidelines. Emissions from own on-site fuel use should be included in this category as well as combustion for the generation of electricity and heat for own use.

The table below details the relationship between direct emission sources and the IPCC source categories for reporting under the National GHG Reporting Regulations.

**Table 16.1: IPCC emission sources associated with Biochar Production**

Sector	Relevant IPCC Code/s	Category Description	Relevant IPCC Gases	Methodology to be used	Methodology reference	Transitional Arrangements (Regulation 18)
Biochar production	1A1c	Combustion emissions from fuel use during the manufacture of secondary and tertiary products from solid fuels including production of biochar. Emissions from own on-site fuel use should be included. Also includes combustion for the generation of electricity and heat for own use in these industries.	CO <sub>2</sub>	Tier 2 or 3	Section 12	Yes
			CH <sub>4</sub>	Tier 1	Section 12	No
			N <sub>2</sub> O	Tier 1	Section 12	No
	1B1ciii	Fugitive emissions during the production of Biochar	CO <sub>2</sub>	Tier 1	Section 16	Yes
			CH <sub>4</sub>	Tier 1	Section 16	No

Please note that the table above details the sectors that should be covered as a minimum. If there are other emission sources, under control of the data provider, that still need to be reported please report them under the relevant categories as listed in Section 5 of this document.

### 16.1. Methodology

There are various methodologies, which could be followed to quantify emissions:

- Activity data should be multiplied with a specific and relevant emission factor which can either be a default (Tier 1) emission factor or country specific emission factor (Tier 2).

- A company could carry out continuous emissions monitoring to measure the quantity of GHG emissions produced (Tier 3).

### 16.2. Activity Data

Activity data could be the quantity of carbonaceous raw material input into the kiln.

### 16.3. Emission Factors

The 2006 IPCC Guidelines do not provide an emission factor for biochar production, for this reason the 2019 IPCC Refinements are referenced (IPCC 2019).

Table 16:2: Emission factors for fugitive emissions from biochar production as detailed in Volume 2, Energy, Table 4.3.3 from the 2019 IPCC Refinements (IPCC 2019)

Gas	Emission Factor (tonne GHG/ tonne of biochar produced)
CO <sub>2</sub>	4.3
CH <sub>4</sub>	0.03

## 17. Coke Production

Combustion emissions are emitted from fuel use during the production of coke. Only direct emissions from the data provider should be reported, as per the Regulations.

### 17.1. IPCC Classification

Stationary combustion emissions from coke production should be classified and reported under source category 1.A.1.c “Manufacture of Solid Fuels and Other Energy Industries” of the 2006 IPCC Guidelines. Emissions from own on-site fuel use should be included in this category as well as combustion for the generation of electricity and heat for own use.

The table below details the relationship between direct emission sources and the IPCC source categories for reporting under the National GHG Reporting Regulations.

**Table 17:1: IPCC emission sources associated with Coke Production**

Sector	Relevant IPCC Code/s	Category Description	Relevant IPCC Gases	Methodology to be used	Methodology reference	Transitional Arrangements (Regulation 18)
Coke production	1A1c	Combustion emissions from fuel use during the manufacture of secondary and tertiary products from solid fuels including production of coke. Emissions from own on-site fuel use should be included. Also includes combustion for the generation of electricity and heat for own use in these industries.	CO <sub>2</sub>	Tier 2 or 3	Section 12	Yes
			CH <sub>4</sub>	Tier 1	Section 12	No
			N <sub>2</sub> O	Tier 1	Section 12	No
	1B1ci	Fugitive emissions during the production of Coke	CH <sub>4</sub>	Tier 1	Section 17	No

Please note that the table above details the sectors that should be covered as a minimum. If there are other emission sources, under control of the data provider, that still need to be reported please report them under the relevant categories as listed in Section 5 of this document.



### 17.2. Methodology

There are various methodologies, which could be followed to quantify emissions:

- Activity data should be multiplied with a specific and relevant emission factor which can either be a default (Tier 1) emission factor or country specific emission factor (Tier 2).
- A company could carry out continuous emissions monitoring to measure the quantity of GHG emissions produced (Tier 3).

### 17.3. Activity Data

Activity data could be the quantity of carbonaceous raw material input into the coke ovens.

### 17.4. Emission Factors

The 2006 IPCC Guidelines do not provide an emission factor for coke production, for this reason the 2019 IPCC Refinements are referenced (IPCC 2019). Please note that this emission factor is for “hard-coal-coke production (coking plants)” using horizontal coke batteries.

**Table 17:2: Emission factors for fugitive CH<sub>4</sub> emissions from coke production as detailed in Volume 2, Energy, Table 4.3.5 from the 2019 IPCC Refinement (IPCC 2019)**

Gas	Emission Factor
CH <sub>4</sub>	4.9 x 10 <sup>-5</sup> tonne/tonne coke produced

## 18. The Oil and Gas Sector (Includes Petroleum Refining)

Emissions from the oil and gas sector start with the extraction and processing of oil and gas and end with distribution of oil and gas products. There are various processes that form part of the life cycle of the oil and gas sector. Petroleum refining is one of these processes.

Different companies might be responsible for different parts of this life cycle. Each company needs to report on the direct emissions within their boundary. This would include direct process emissions, energy related emissions and fugitive emissions.

Petroleum refining is an industrial process in which crude oil is transformed into products that include liquefied petroleum gas (LPG), petrol, diesel, kerosene, fuel oils and bitumen, amongst others. Reporting under this subcategory is aimed at enterprises that produce petroleum products for both domestic and international markets.

This section provides the details and data required to estimate emissions associated with the oil and gas sector.

### 18.1. IPCC Classification

The table below details the IPCC source categories for the oil and gas sector.

Table 18.1: IPCC classification of emissions for oil and gas sector

Sector	Relevant IPCC code/s	Definition	Relevant IPCC Gases	Tier	Methodology reference	Transitional arrangements
	1A1b	All combustion activities supporting the refining of petroleum products including on-site combustion for the generation of electricity and heat for own use.	CO <sub>2</sub>	2 or 3	Section 12	Yes
			CH <sub>4</sub>	1, 2 or 3	Section 12	No
			N <sub>2</sub> O	1, 2 or 3	Section 12	No
	1A1ci	Emissions arising from fuel combustion for the production of coke, brown coal briquettes and patent fuel.	CO <sub>2</sub>	2 or 3	Section 12	Yes
	1B2b	Emissions from exploration, production, processing, transmission, storage, distribution, flaring/venting, leakage at gas facilities.	CO <sub>2</sub>	2 or 3	Section 18	No
			CH <sub>4</sub>	1, 2 or 3	Section 18	No
1B2ai	Oil Exploration: Fugitive emissions associated with field activities prior to	CO <sub>2</sub>	1, 2 or 3	Section 18	No	

Oil and Gas		production – eg exploratory drilling, field development and well development etc	CH <sub>4</sub>	1, 2 or 3	Section 18	No
	1B2a	Oil Production and Upgrading: Onshore Production				
		Oil Production and Upgrading: Offshore Production	CO <sub>2</sub>			
		Oil Production and Upgrading: Crude Bitumen or Heavy Oil Upgrading to Synthetic Crude Oil (From Oil Sands or Oil Shale)	CH <sub>4</sub>	1, 2 or 3	Section 18	Yes
			N <sub>2</sub> O			
	1B2aiii	Oil transport: Marine	CO <sub>2</sub>			
		Oil Transport: Pipeline	CH <sub>4</sub>	1, 2 or 3	Section 18	Yes
		Oil Transport: Tanker Trucks and Rail Cars				
	1B2aiv	Oil Refining: Heavy Oil	CO <sub>2</sub>			
		Oil Refining: Conventional and Synthetic Crude Oil	CH <sub>4</sub>	1, 2 or 3	Section 18	Yes
		N <sub>2</sub> O				
1B2av	Distribution of Oil Products: (Gasoline, Diesel, Aviation Fuel and Jet Kerosene, Gas oil (intermediate Refined Products))					
1B2avi	Other: Anomalous leak events can occur across segments of the Oil systems	CH <sub>4</sub>	1, 2 or 3	Section 18	Yes	
1B2avii	Abandoned Oil Wells: Unplugged and plugged abandoned wells	CH <sub>4</sub>	1, 2 or 3	Section 18	Yes	
Gas 1B2b	1B2bi	Gas Exploration: Fugitive emissions associated with field activities prior to production – eg exploratory drilling, field development and well development etc	CH <sub>4</sub> CO <sub>2</sub>	1, 2 or 3	Section 18	No
	1B2bii	Gas Production and Gathering: Onshore gas production	CH <sub>4</sub> CO <sub>2</sub> N <sub>2</sub> O	1, 2 or 3	Section 18	No
		Gas Production and Gathering: Offshore gas production	CH <sub>4</sub> CO <sub>2</sub> N <sub>2</sub> O	1, 2 or 3	Section 18	No
		Gas Production and Gathering:	CH <sub>4</sub> CO <sub>2</sub>	1, 2 or 3	Section 18	No

		Gathering and boosting stations (with multiple emissions sources on site, such as compressors, pneumatic controllers and tanks) and gathering pipelines.	N <sub>2</sub> O			
1B2biii		Gas Processing: Gas Processing Plants without Acid Gas Removal	CH <sub>4</sub> CO <sub>2</sub> N <sub>2</sub> O	1, 2 or 3	Section 18	No
		Gas Processing: Sour Gas or Acid Gas Removal Plants	CH <sub>4</sub> CO <sub>2</sub> N <sub>2</sub> O	1, 2 or 3	Section 18	No
1B2biv		Gas Transmission and Storage: Transmission pipeline Systems compressor stations	CH <sub>4</sub> CO <sub>2</sub>	1, 2 or 3	Section 18	No
		Gas Transmission and Storage: Storage Facilities	CH <sub>4</sub> CO <sub>2</sub>	1, 2 or 3	Section 18	No
		Gas Transmission and Storage: Liquefied Natural Gas System import stations, export stations, storage stations and transport	CH <sub>4</sub> CO <sub>2</sub>	1, 2 or 3	Section 18	No
1B2bv		Gas Distribution Pipelines, metering and regulating stations	CH <sub>4</sub> CO <sub>2</sub>	1, 2 or 3	Section 18	No
1B2bvi		Gas Post -Meter Consumer appliances, power plants and natural gas fuelled vehicles	CH <sub>4</sub> CO <sub>2</sub>	1, 2 or 3	Section 18	No
1B2bvii		Other Anomalous leak events (e.g emergency pressure releases and unintentional gas spills)	CH <sub>4</sub>	1, 2 or 3	Section 18	No
1B2bviii		Abandoned Gas Wells: Unplugged and plugged abandoned wells	CH <sub>4</sub>	1, 2 or 3	Section 18	No
2B8g		Hydrogen production	CO <sub>2</sub>	2 or 3	Section 36	Yes

Please note that the table above details the sectors that should be covered as a minimum. If there are other emission sources such as waste water or solid waste disposal, under control of the data provider, please report them under the relevant categories as listed in Section 5 of this document.

**18.2. Methodology**

The sector specific guidance on the oil and gas sector is contained in four different emissions source categories in the 2006 IPCC Guidelines. For this reason please refer to the following sections of these guidelines:

- stationary combustion, Section 12
- fugitive emissions, Section 18
- hydrogen production, Section 36
- coke production, Section 17
- electricity production, Section 13

Emissions from CO<sub>2</sub> captured from steam reformers should be quantified as per Section 36 and reported separately and methodology used to quantify the amounts of CO<sub>2</sub> captured described and submitted to the competent authority for verification.

### 18.3. Fugitive Emissions

Oil and gas fugitive emissions come from exploration, production, refining activities, distribution/or transport, storage, processing and refining activities. Under South African circumstances, emissions to be included under this sources category include equipment leaks, venting, flaring, incineration and accidental releases, where data is available.

As there are limited oil and gas activities in South Africa, the Tier 1 approach should be used for oil and gas fugitive emission estimates, whereby;

$$\text{Emission} = (A_{\text{gas, industry}}) \times (EF_{\text{gas, industry}}) / 1000$$

Where:

Emission	=	Annual emissions (tonnes)
$A_{\text{gas, industry}}$	=	activity value (units of activity),
$EF_{\text{gas, industry}}$	=	emission factor (kg/unit of activity)

A factor of 1000 to convert from kilograms to tonnes of the relevant Greenhouse gas

The industry segments define activities being carried out, for example well drilling, gas transmission and storage, oil production, etc. The activity value relates to throughput. Please refer to Annexure B for country specific and default emission factors for fugitive emissions.

### 18.4. Activity Data

The activity data for Tier 1 and Tier 2 could be:

- Quantity of carbonaceous fuel used, gathered from raw material invoices or shipping documents.
- Production records such as crude throughput, flaring volumes and production outputs.

Under Tier 3 a mass balance or continuous emission measurement approach is used. For a mass balance approach the activity data is the quantities of the input and output materials. For continuous emission measurement the activity data would be the actual measured emissions levels.

#### **18.5. Emission Factors/Parameters**

For default emission factors to be used under the Tier 1 approach please refer to Annexures A and B.

Country specific emission factors can be used under the Tier 2 approach. In cases where data providers have access to more accurate country specific emission factors, these should be submitted to the competent authority for review.

The Tier 3 methodology does not make use of emission factors but instead uses parameters such as the carbon content of the actual fuel combusted.

## 19. Coal-to-liquids and Gas-to-Liquids/Chemicals Processes

Coal-to-liquids (CTL) and gas-to-liquids (GTL) and gas-to-chemicals (GTC) processes involve converting coal and natural gas into syngas and reformed gas. The syngas and/or reformed gas is then converted to liquid fuels, fuel components and chemicals through the application of technologies such as the Fischer-Tropsch process. This section details the methods and data necessary to estimate emissions from CTL, GTL, and GTC processes.

### 19.1. IPCC Classification

The table below details the relationship between direct emission sources and the corresponding IPCC source categories for reporting under the national GHG reporting regulations.

Table 19:1: IPCC classification of emissions for coal-to-liquids, gas-to liquids and gas-to-chemicals

Sector	Relevant IPCC Code/s	Category Description	Relevant IPCC Gases	Methodology to be used	Methodology reference	Transitional arrangements
Coal-to-liquids, Coal-to- Chemicals, Gas-to- liquids, Gas-to- chemicals	1A1a	Sum of emissions from main activity producers of electricity generation, combined heat and power generation, and heat plants should be assigned to the sector where they were generated and not dealt with under 1A1a.	CO <sub>2</sub>	Tier 2 or 3	Section 12	Yes
			CH <sub>4</sub>	Tier 1	Section 12	No
			N <sub>2</sub> O	Tier 1	Section 12	No
	1A1c	Combustion emissions from fuel use during the manufacture of secondary and tertiary products from solid fuels including production of synthetic fuels and chemicals. Emissions from own on-site fuel use should be included. Also include combustion for the generation of electricity and heat for own use in these industries.	CO <sub>2</sub>	Tier 2 or 3	Section 12	Yes
			CH <sub>4</sub>	Tier 1	Section 12	No
			N <sub>2</sub> O	Tier 1	Section 12	No
	1B1	Fugitive emissions from opencast and underground coal mining. Emissions include emissions from post-mining handling of coal.	CO <sub>2</sub>	Tier 2 or 3	Section 23	Yes
			CH <sub>4</sub>	Tier 2 or 3	Section 23	Yes
	1B2b	Emissions from exploration, production, processing, transmission, storage, distribution, flaring/venting and leakage at gas facilities.	CO <sub>2</sub>	2 or 3	Section 18	No
CH <sub>4</sub>			1, 2 or 3	Section 18	No	

Sector	Relevant IPCC Code/s	Category Description	Relevant IPCC Gases	Methodology to be used	Methodology reference	Transitional arrangements
	1B3	Fugitive emissions from synfuels and gas-to-liquids/chemicals processes.	CO <sub>2</sub>	Tier 2 or 3	Section 19	Yes
			CH <sub>4</sub>	Tier 2 or 3	Section 19	Yes
	2B1	Ammonia production	CO <sub>2</sub> (+CH <sub>4</sub> )	Tier 2 or 3	Section 30	Yes
	2B2	Nitric acid production	N <sub>2</sub> O	Tier 2 or 3	Section 31	Yes
	4D2	Industrial wastewater and discharge	CH <sub>4</sub>	Tier 1	Section 47	No
			N <sub>2</sub> O	Tier 1	Section 47	No

Please note that the table above details the sectors that should be covered as a minimum. If there are other emission sources, under control of the data provider, that still need to be reported please report them under the relevant categories as listed in Section 5 of this document.

The schematic below explains the emissions process flow involved with CTL, CTC, GTL and GTC processes against the relevant IPCC reporting classifications.

Figure 17.1: Process flow for Coal-to-liquid and Gas-to-liquid.

### 19.2. Methodology

For CTL, GTL and GTC please refer to the following sections:

- Coal mining – Section 23
- Natural Gas Production and transmission – Section 12 and 18
- Gasification Fischer-Tropsch Process – Section 19
- Ammonia production – Section 30
- Nitric Acid production – Section 31
- Electricity production – Section 12
- On-site wastewater treatment – Section 47

In addition to the above-mentioned methodologies, gasification emissions from these processes are calculated using a stoichiometric/mass balance approach. A carbon-balance spreadsheet jointly developed by the DEA and SASOL and separately by the DEA and PETROSA is used for the CTL, GTC and GTL processes and follows the Tier 3 approach. Therefore, guidance in this section focuses more on the allocation of emissions.



### 19.3. Fugitive Emissions

Fugitive emissions are classified as intentional or unintentional release of greenhouse gases during the extraction, processing and delivery of fossil fuels to the point of final use.

The fugitive emissions from natural gas are classified in the table below:

**Table 19:2: IPCC categories for fugitive emissions from natural gas**

1B: Fugitive emission from fuels	1B2: Oil and natural gas	1B2b: Natural gas	1.B2bi: Venting	
			1.B2bii: Flaring	
			1.B2biii: All other	1B2biii1: Exploration
				1B2biii2: Production
				1B2biii3: Processing
				1B2biii4: Transmission and storage
				1B2biii5: Distribution
1B2biii6: Other				

Fugitive emissions from natural gas emission can be quantified according to the three Tiers. The various Tiers are summarised below:

- If limited data is available, then Tier 1 is good practice. Using the Tier 1 methodology the default emission factors (to be found in Annexure B of these guidelines) should be used in addition to the data provider's activity data to calculate total emissions.
- The Tier 2 methodology is based on country specific emission factors together with activity data from the data provider.
- The Tier 3 approach uses direct measurements on a site-specific basis.

Refer to Section 4.2 of the 2006 IPCC Guidelines, Volume 2, Chapter 4 for guidance and equations to be used for fugitive emission quantification from oil and natural gas systems.

### 19.4. Activity Data

Activity data could include emissions or flow metering records, purchase receipts, delivery receipts, production reports, carbon content lab results or stock inventory documentation.

### 19.5. Emission Factors

For default IPCC emission factors please refer to Annexures A, B and C of this document.

## 20. Aviation Industry

Aviation emission estimates in South Africa should be estimated from aircraft combustion of jet fuel and aviation gasoline. Aircraft emissions are mainly CO<sub>2</sub> and water, with little or no emissions of CH<sub>4</sub> and N<sub>2</sub>O in modern engines. Generally, about 10 per cent of aircraft emissions are produced during airport ground level operations and during landing and taking off, and the other 90 per cent at higher altitudes. For the purpose of the emissions inventory, a separation should be made between domestic and international aviation, whereby the latter should not be included in the national total emission but estimated for reporting only. Domestic aviation is when an aircraft departs and arrives in the same country, and international aviation is when an aircraft departs from one country and arrives in another.

This annex details the methods and data necessary to estimate direct CO<sub>2</sub> emissions emanating from entities in the aviation industry in South Africa.

### 20.1. IPCC Classification

The table below details the relationship between direct emission sources and the corresponding IPCC source categories for reporting under the national GHG reporting regulations.

Table 20:1: IPCC classification of emissions for the aviation industry

Sector	Relevant IPCC code/s	Definition	Relevant IPCC Gases	Tier	Methodology reference	Transitional arrangements
Aviation	1A3a <sup>ii</sup>	Emissions from civil domestic passenger and freight traffic that departs and arrives in the same country (commercial, private, agriculture, etc.), including take-offs and landings for these flight stages.	CO <sub>2</sub>	2 or 3	Section 20	Yes
			N <sub>2</sub> O	1, 2 or 3	Section 20	No
			CH <sub>4</sub>		Section 20	No

Please note that the table above details the sectors that should be covered as a minimum. If there are other emission sources, under control of the data provider, that still need to be reported please report them under the relevant categories as listed in Section 5 of this document.

### 20.2. Methodology

The aviation sector in South Africa has been categorised as a Key Category, which requires that Tier 2 and Tier 3 Methodologies be used to calculate direct emissions from fuel combustion activities in this sector.

### Method 1 – IPCC Tier 1 Methodology

$$\text{Emissions} = \text{Fuel} \times \text{EF}_j / 1000$$

Where:

Emissions	=	emissions (tonnes)
Fuel	=	fuel type consumed in (TJ), e.g. diesel, petrol, etc.
EF <sub>j</sub>	=	emission factor for fuel type j, (kg/TJ)

Emissions from military aviation fuel use can also be estimated using the above equation. Aviation emission default factors for CO<sub>2</sub>, CH<sub>4</sub> and N<sub>2</sub>O emissions can be obtained from Tables 3.6.4, and 3.6.5 of the 2006 IPCC Guidelines, please refer to section 3.6.1.2 of Volume 2, Chapter 3.

### Method 2: IPCC Tier 2 Methodology

Emissions from combustion are estimated using fuel statistics and country-specific emission factors.

Tier 2 methodology is only applicable for jet fuel use in jet aircraft engines. The fuel consumption, number of landing/take-off cycles (LTO) and cruise operations must be known for domestic aviation, preferably by aircraft type. Consult Volume 2, Chapter 3, Section 3.6 of the 2006 IPCC Guidelines for guidance on calculations. Table 18.2 below outlines some of the key guidelines regarding Tier 2 measurements pertaining to both international (source category 1A3ai) and domestic aviation (source category 1A3aii). At high level the total emissions of tier 2 approach are as follows:

$$\text{Emissions} = \text{LTO Emissions} + \text{Cruise Emissions}$$

LTO Emissions are calculated using the Equation below:

$$\text{LTO Emissions} = \text{Number of LTOs} \times \text{Emission Factor of LTO}$$

Cruise Emissions are calculated using the following Equations below:

$$\text{LTO Fuel Consumption} = \text{Number of LTOs} \times \text{Fuel Consumption per LTO}$$

$$\text{Cruise Emissions} = (\text{Total Fuel Consumption} - \text{LTO Fuel Consumption}) \times \text{Emission Factor Cruise}$$

Detailed spreadsheet on the factors and the equations is uploaded on SAGERS reporting portal at:

<https://ghgreportingpublic.environment.gov.za/GHGLanding/SAGERSHome.html>

### Method 3: IPCC Tier 3 Methodology

Tier 3 methodologies use movement data for individual flights which includes information on the origin and destination, aircraft type and frequency of individual flights, among others, making this method the most accurate but very data intensive.

Volume 2, Chapter 3, Section 3.6 of the 2006 IPCC Guidelines provides details on the two methods available, namely Tier 3A: origin and destination (OD) data and Tier 3B: full flight trajectory information. The Table below outlines some of the key guidelines regarding Tier 3 measurements.

Table 20:2: Guidelines on Tier 3 methodology for IPCC source categories: 1A3ai and 1A3aii

Tier 3A: Origin and destination	Tier 3B: Full flight trajectory
Takes into account that the amount of emissions generated varies between phases of flight, and that fuel burn is related to flight distance (i.e. aircraft use a higher amount of fuel per distance for the LTO cycle compared to the cruise phase).	Calculates fuel burnt and emissions throughout the full trajectory of each flight segment, using aircraft and engine-specific aerodynamic performance information. The use of this method requires sophisticated computer models.

### 20.3. Activity Data

Activity data could be in the form of purchase receipts or delivery receipts. Please see data requirements for the different Tiers in table below.

**Table 20.3: Activity data requirements for domestic aviation**

Data	Tier 1	Tier 2	Tier 3A	Tier 3B
Aviation gasoline consumption	X			
Jet fuel consumption	X	X		
LTO by aircraft type		X		
Origin and destination by aircraft type			X	
Full flight movements with aircraft and engine data				X

### 20.4. Emission Factors

For default emission factors to be used under the Tier 1 approach please refer to Annexure A. Default fuel densities and calorific values are provided in Annexure D. Alternatively own fuel analysis can be used as a basis for the calculation.

Country specific emission factors can be used under the Tier 2 approach. In cases where data providers have access to more accurate country specific emission factors, these should be submitted to the competent authority for review as per section 9.1.

The Tier 3 methodology does not make use of emission factors but instead uses parameters as found in the template in <https://ghgreporting-public.environment.gov.za>.

## 21. Water-borne Navigation (1.A.3.d)

This annex details the methods and data necessary to estimate emissions from all water-borne transport including coastal and inland waterways.

Emissions from this source category should include all water-borne transport from recreational craft to large ocean-going ships. For the purpose of the emissions inventory, a separation should be made between domestic and international water-borne navigation, whereby the later should not be included in the national total emission but estimated for reporting only. Domestic navigation is when a vessel departs and arrives in the same country, and international navigation is when a vessel departs from one country and arrives in another.

The emissions from fishing vessels should be reported here. The emissions for processing of fished products involving stationary combustion should be reported under 1A4cii. The sources covered within this category are detailed in the table below, however companies with water-borne navigation entities may have emissions which fall within other categories of the IPCC Guidelines, such as stationary combustion emissions. Please refer to Section 5 of this report for further guidance on the other potential emission sectors which may be relevant.

Table 21:1: IPCC sectoral breakdown covered by Water-borne Navigation

1. Energy	1A. Fuel Combustion Activities	1A3 Transport	1A3d Water-borne Navigation	1A3di International water-borne navigation
				1A3dii Domestic water-borne navigation (including fishing vessels)
		1A4 Other Sectors	1A4c Agriculture / Forestry / Fishing / Fish Farms	1A4ciii Fishing (stationary combustion)
		1A5 Non-Specified	1A5b Mobile	1A5bii Mobile (water-borne component)
		1A5c Multilateral Operations		

### 21.1. IPCC Classification

Table 21:2: IPCC Classification of emissions for Water-borne Navigation

Sector	Relevant IPCC code/s	Definition	Relevant IPCC gases	Tier	Methodology reference	Transitional arrangements
Water-borne Navigation	1A3dii	Emissions from fuels used by vessels that depart and arrive in the same country, including fishing vessels.	CO <sub>2</sub>	2 or 3	Section 21	Yes
			CH <sub>4</sub>	1, 2 or 3	Section 21	No
			N <sub>2</sub> O	1, 2 or 3	Section 21	No

### 21.2. Methodology

Tier 1 and Tier 2 methodologies are available for calculating emissions from water-borne navigation (note that there is no Tier 3 methodology provided in the 2006 IPCC Guidelines).

Under South Africa's conditions, the Tier 1 approach is adequate for estimating marine navigation emissions, whereby:

$$\text{Emissions} = (\text{Fuel}) \times (\text{EF})/1000$$

Where:

Emissions = emissions (tonnes)

(Fuel) = fuel type consumed in (Tj), e.g. diesel, petrol, etc.

(EF) = emission factor for fuel type j, (kg/Tj)

A factor of 1000 to convert from kilograms to tonnes of the relevant Greenhouse gas

### 21.3. Activity data

Activity data on fuel consumption is used to estimate the emissions available. Activity data should also include the fuel consumed by power auxiliary engines such as refrigeration plants, for example, on the vessel. In the event that company specific fuel consumption activity data isn't available, companies can use consumption factors provided in Tables 3.5.5 and 3.5.6 of the 2006 IPCC Guidelines, please refer to section 3.5.1.3 of Volume 2, Chapter 3.

### 21.4. Emission Factors

The Tier 1 approach uses default emission factors and company specific fuel consumption activity data. This approach uses data which is fuel-type-specific, and thus specific emissions factors for each fuel type used are required. The Tier 2 approach makes use of country specific emission factors which are specific to the type of navigation vessel, the fuel type and engine type. This is multiplied by company specific fuel consumption activity data. Equation 3.5.1 of the 2006 IPCC Guidelines, Volume 2, Chapter 3, section 3.5.1.1 can be used for both the Tier 1 and Tier 2 approaches, with slight variations between the two methods

Further guidance on the selection of emission factors is provided in the 2006 IPCC Guidelines, please refer to section 3.5.1.2 of Volume 2, Chapter 3.

## 22. Railways

This section should include emission estimates from railway locomotives (excluding conveyor belts and trucks) that use fossil fuel (mainly coal or diesel). Indirect emissions from electric locomotives are covered under direct electricity generation emissions.

With coal as an input, the emissions should be estimated using an approach similar to conventional steam boilers, which are covered in the stationary combustion chapter of Volume 2 of the 2006 IPCC Guidelines.

### 22.1. IPCC Classification

Table 22:1: IPCC classification of emissions for railways

Sector	Relevant IPCC code/s	Definition	Relevant IPCC gases	Tier	Methodology reference	Transitional arrangements
Railways	1A3c	Emissions from railway transport for both freight and passenger traffic routes.	CO <sub>2</sub>	2 or 3	Section 22	Yes
			CH <sub>4</sub>	1, 2 or 3	Section 22	No
			N <sub>2</sub> O	1, 2 or 3	Section 22	No

Please note that the table above details the sectors that should be covered as a minimum. If there are other emission sources, under control of the data provider, that still need to be reported please report them under the relevant categories as listed in Section 5 of this document.

### 22.2. Methodology

Under South Africa conditions, Tier 1 and Tier 2 approaches would be relevant, whereby:

#### Method 1: IPCC Tier 1 approach

$$\text{Emissions} = (\text{Fuel})_j \times (\text{EF})_j / 1000$$

Where;

Emissions = emissions (tonnes)

(Fuel)<sub>j</sub> = fuel type j consumed in (TJ)

(EF)<sub>j</sub> = emission factor for fuel type j, (kg/TJ)

j = fuel type

A factor of 1000 to convert from kilograms to tonnes of the relevant Greenhouse gas

#### Method 2: IPCC Tier 2 approach

$$\text{Emissions} = (\text{Fuel})_i \times (\text{EF})_i / 1000$$

Where;

Emissions = emissions (tonnes)

(Fuel)<sub>i</sub> = fuel type j consumed in (TJ)

(EF)<sub>i</sub> = emission factor for fuel type j, (kg/TJ)



i = locomotive type.

A factor of 1000 to convert from kilograms to tonnes of the relevant Greenhouse gas

### 22.3. Activity Data

Activity data is fuel consumption expressed in energy units (Terajoule). Please refer to Annexure D to select net calorific values (NCVs) to convert from indigenous units to energy units.

### 22.4. Emission Factors

Table 22:2: Default emission factors for the most common fuels used for rail transport

Gas	Diesel (kg/TJ)			Sub-bituminous Coal (kg/TJ)		
	Default	Lower	Upper	Default	Lower	Upper
CO <sub>2</sub>	74 100	72 600	74 800	96 100	72 800	100 000
CH <sub>4</sub> <sup>1</sup>	4.15	1.67	10.4	2	0.6	6
N <sub>2</sub> O <sup>1</sup>	28.6	14.3	85.8	1.5	0.5	5

Notes:

1 For an average fuel consumption of 0.35 litres per bhp-hr (brake horsepower-hour) for a 4000 HP locomotive, (0.47 litres per kWh for a 2983 kW locomotive).(Dunn, 2001).

2 The emission factors for diesel are derived from (EEA, 2005) (Table 8-1), and from Table 2.2 of the Stationary Combustion chapter for coal.

## 23. Coal Mining

Coal related fugitive emissions to be considered in the South African circumstances include the following activities;

- i. Coal mining and handling
  - a. Mining emissions
  - b. Post mining emissions

The main sources of fugitive emissions from coal mining and handling in South Africa include emissions from underground and open pit mining activities and emissions from abandoned (decommissioned) mines. A small amount of emissions would also come from flaring of coal mine waste gas and post-mining activities such as from stockpiling coal.

### 23.1. IPCC Classification

The definition for reporting of emissions under category 1.A.1.c.ii Other Energy Industries is as follows:

Combustion emissions arising from the energy-producing industries own (on-site) energy use not mentioned above or for which separate data are not available. This includes the emissions from own-energy use to produce charcoal, bagasse, saw dust, cotton stalks and carbonizing of biofuels as well as fuel used for coal mining, oil and gas extraction and the processing and upgrading of natural gas. This category also includes emissions from pre-combustion processing for CO<sub>2</sub> capture and storage. Combustion emissions from pipeline transport should be reported under 1A3e (IPCC 2006, V2, Ch2, p2.8).

Table 23:1: IPCC Classification of emissions for Mining of Fuels (coal mining)

Sector	Relevant IPCC code/s	Definition	Relevant IPCC Gases	Tier	Methodology reference	Transitional arrangements
Mining of fuels	1A1ci	Emissions arising from fuel combustion for the production of coke, brown coal briquettes and patent fuel.	CO <sub>2</sub>	2 or 3	Section 12	Yes
			CH <sub>4</sub>	1, 2 or 3	Section 12	No
			N <sub>2</sub> O	1, 2 or 3	Section 12	No
	1A1cii	Combustion emissions arising from the energy-producing industries own (on-site) energy use not mentioned above or for which separate data are not available. This includes the emissions from own-energy use for the production of charcoal, bagasse, saw dust, cotton stalks and carbonizing of	CO <sub>2</sub>	2 or 3	Section 12	Yes
			CH <sub>4</sub>	1, 2 or 3	Section 12	No
			N <sub>2</sub> O	1, 2 or 3	Section 12	No

Sector	Relevant IPCC code/s	Definition	Relevant IPCC Gases	Tier	Methodology reference	Transitional arrangements
		biofuels as well as fuel used for coal mining, oil and gas extraction and the processing and upgrading of natural gas.				
	1B1ai	Underground Coal Mining	CO <sub>2</sub>	2 or 3	Section 23	Yes
	1B1ai	Underground Post-Mining (Handling & Transport)	CH <sub>4</sub>	1, 2 or 3	Section 23	Yes
	1B1aii	Surface Coal Mining	CO <sub>2</sub>	2 or 3	Section 23	Yes
	1B1aii	Surface Post-Mining (Storage and Transport)	CH <sub>4</sub>	1, 2 or 3	Section 23	Yes

(Source: IPCC 2006, Volume 2, Chapters 2 & 4)

Please note that the table above details the sectors that should be covered as a minimum. If there are other emission sources, under control of the data provider, that still need to be reported please report them under the relevant categories as listed in Section 5 of this document.

The figure below details the process flow for emissions from mining of fuels.

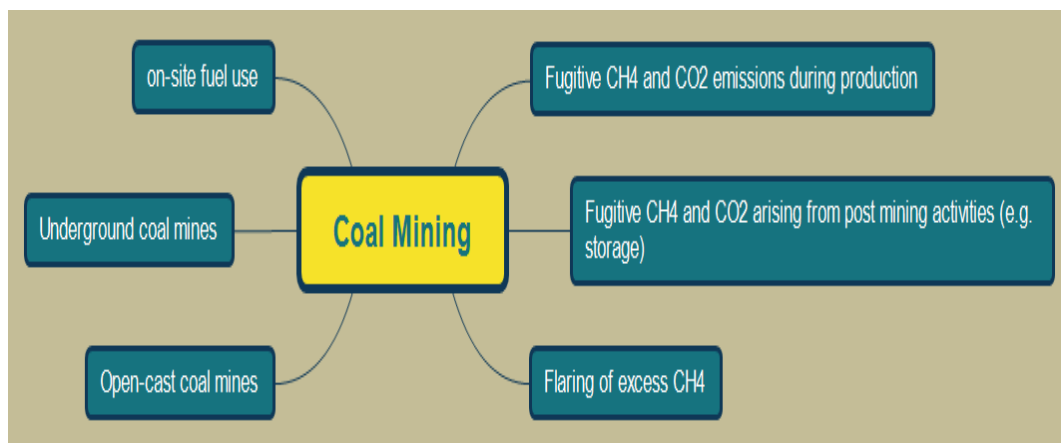

Figure 23.1: Process flow for Mining of Fuels (coal mining)

### 23.2. Methodology

#### During coal mining

**Method 1&2: IPCC Tier 1&2 approach;**

For reporting under this categories, Data Providers are advised to use tier 2 method, as it is the most accurate. If for any reason, Data Providers chooses to report using Tier 1, the default Emission Factors as per IPCC refinements can be used. Please note that in every reporting cycle, SAGERS will be pre-populated with emission factors for tiers 1 and 2. For tiers 1 and 2 the following methodology is followed:

$$\text{Emissions} = (\text{Emission Factor}) \times (\text{Opencast and/or Underground Coal Production}) \times (\text{CF})$$

Where units are:

- Emissions (tonnes per year)
- Emission Factor ( $\text{m}^3$  per tonne) (See B.1 in annexure B)
- Opencast/Underground Coal Production (tonne per year)
- CF = Conversion Factor: This is the density of  $\text{CH}_4$  or  $\text{CO}_2$  and converts volume of  $\text{CH}_4$  or  $\text{CO}_2$  to mass of  $\text{CH}_4$  or  $\text{CO}_2$ . The density is taken at  $20^\circ\text{C}$  and 1 atmosphere pressure and has a value of  $0.67 \times 10^{-3}$  tonne  $\text{m}^{-3}$  and  $1.843 \times 10^{-3}$  tonnes  $\text{m}^{-3}$  respectively.

**Method 3: IPCC Tier 3 approach;**

For a tier 3 methodology a company will have to carry out continuous emissions monitoring to measure the quantity of emissions produced. This option requires sophisticated measurement equipment.

**Post mining emissions:**

$$\text{emissions} = (\text{CH}_4 \text{ Emission Factor}) \times (\text{Opencast and/or Underground Coal Production}) \times (\text{CF})$$

Where units are:

- Emissions (tonnes per year)
- Emission Factor ( $\text{m}^3$  per tonne) (see B.1 in annexure B)
- Underground Coal Production (tonne per year)
- CF = This is the density of  $\text{CH}_4$  or  $\text{CO}_2$  and converts volume of  $\text{CH}_4$  or  $\text{CO}_2$  to mass of  $\text{CH}_4$  or  $\text{CO}_2$ . The density of  $\text{CH}_4$  and  $\text{CO}_2$  is taken at  $20^\circ\text{C}$  and 1 atmosphere pressure and has a value of  $0.67 \times 10^{-3}$  tonne  $\text{m}^{-3}$  and  $1.843 \times 10^{-3}$  tonnes  $\text{m}^{-3}$  respectively.

In the case of underground mining activities:

- The net emissions generated = emissions from underground mining + post mining – CH<sub>4</sub> recovered and used for energy production or flared.
- Emissions from use of CH<sub>4</sub> recovery for energy use should be reported under 1A2i (energy combustion)
- If CH<sub>4</sub> is flared, the emissions associated with flaring should be reported under 1B1c (solid fuel transformation)

### Method 1: CO<sub>2</sub> and CH<sub>4</sub> from Methane Flaring - IPCC Tier 2 approach;

In case of flaring, the following methodology should be used to calculate the associated CO<sub>2</sub> and CH<sub>4</sub> emissions;

#### CO<sub>2</sub> from flaring:

- Emissions of CO<sub>2</sub> = 0.98 x (Volume of methane flared) x (CF) x (Stoichiometric mass factor)**

#### CH<sub>4</sub> from in unburnt gases

- Emissions of unburnt CH<sub>4</sub> = 0.02 x (Volume of methane flared) x (CF)**

Where units are:

- Emissions of CO<sub>2</sub> from methane combustion (tonnes per year)
- Volume of methane oxidised (m<sup>3</sup> per year)
- Stoichiometric Mass Factor is the mass ratio of CO<sub>2</sub> produced from full combustion of unit mass of methane and is equal to 2.75
- CF = Conversion Factor: This is the density of CH<sub>4</sub> and converts volume of CH<sub>4</sub> to mass of CH<sub>4</sub>. The density is taken at 20°C and 1 atmosphere pressure and has a value of 0.67 x 10<sup>-3</sup> tonne m<sup>-3</sup>.

Note: 0.98 represents the combustion efficiency of natural gas that is flared.

### 23.3. Activity data

The activity data is the value of coal mined, stored or transported. In preparation for the activity data on coal mining for the purpose of quantifying fugitive emissions, the following guidance must be observed:

- Amount of coal should be reported based on Run-of-Mine (ROM) statistics and not saleable coal. Using saleable coal statistics leads to underestimation of emissions from coal mining
- Company reporting should indicate the type of mine that it is operating (Opencast and/or underground)
- In quantifying CH<sub>4</sub> emissions from post-mining activities (storage), the same amount of ROM coal mining statistics used for CH<sub>4</sub> emissions from production should be applied.

CONTINUES ON PAGE 130 OF BOOK 2

Printed by and obtainable from the Government Printer, Bosman Street, Private Bag X85, Pretoria, 0001  
Contact Centre Tel: 012-748 6200. eMail: info.egazette@gpw.gov.za  
Publications: Tel: (012) 748 6053, 748 6061, 748 6065



# Government Gazette Staatskoerant

REPUBLIC OF SOUTH AFRICA  
REPUBLIEK VAN SUID AFRIKA

Vol. 688

7

October  
Oktober

2022

No. 47257

**PART 2 OF 4**

N.B. The Government Printing Works will not be held responsible for the quality of "Hard Copies" or "Electronic Files" submitted for publication purposes

ISSN 1682-5845



9 771682 584003



**AIDS HELPLINE: 0800-0123-22 Prevention is the cure**

#### 23.4. Emission Factors

See<sup>13</sup> Annexure B of this document for country-specific emission factors for coal mining.

---

<sup>13</sup> Local Coal Research Institute



## 24. Mining and Quarrying

This category comprises all mining activities including:

- mining of metal ores
- other mining and quarrying

The mining of fuel sources such as coal and uranium is covered in Annexure 11.

Mining is a key category for South Africa and thus reporting of emissions on either Tier 2 or Tier 3 is required. Mining has a specific stationary combustion category within the IPCC Regulations (1A2i Mining and Quarrying). However, emissions produced by a mining company are not all unique to this category of emissions. All stationary combustion emissions should be reported in this sector.

### 24.1. IPCC Classification

Stationary combustion emissions from mining, should be classified and reported under source category "1.A.2.i Mining and quarrying" of the 2006 IPCC Guidelines (IPCC 2006, V2, Ch2, p2.9). The stationary combustion emissions from fuel use during the mining procedure is to be reported under this category.

Table 24:1: IPCC classification of emissions for Mining and Quarrying

Sector	Relevant IPCC code/s	Definition	Relevant IPCC Gases	Tier	Methodology reference	Transitional arrangements
Mining and Quarrying	1A2i	Emissions from the mining operation and processing plants.	CO <sub>2</sub>	2 or 3	Section 12	Yes
			CH <sub>4</sub>	1, 2 or 3	Section 12	No
			N <sub>2</sub> O	1, 2 or 3	Section 12	No

Please note that the table above details the sectors that should be covered as a minimum. If there are other emission sources, under control of the data provider, that still need to be reported please report them under the relevant categories as listed in Section 5 of this document.

### 24.2. Methodology

There are various possible methodologies, which could be followed to quantify emissions:

- Activity data should be multiplied by a specific and relevant emission factor. Refer to Annexure 1 of these guidelines for the quantification of emissions from stationary combustion.
- A company could carry out continuous emissions monitoring to measure the quantity of emissions produced.

### 24.3. Activity Data

Activity data could be the quantity of fuel burnt at the mining operation/processing plant.

### 24.4. Emission Factors

For default IPCC and country-specific fuel emission factors please refer to Annexure A, B and C and for South African specific calorific values please refer to Annexure D of this document.

## 25. Carbon Capture and Storage

The carbon capture and storage (CCS) process is a chain consisting of four steps: the capture and compression of CO<sub>2</sub> (usually at a large industrial installation), its transport to a storage location, the injection of the CO<sub>2</sub> into the storage facility and its long-term isolation from the atmosphere (geological storage). The emissions quantified under this category are the leakage emissions throughout the CCS process.

The 2006 IPCC Guidelines provide leakage emission estimation guidance for carbon dioxide transport, injection, and geological storage (CCGS) only. Emissions from the capture and compression of CO<sub>2</sub> are not reported in this category. Emissions (and reductions) associated with CO<sub>2</sub> capture and compression should be reported under the IPCC sector in which capture takes place (for example, stationary combustion or industrial activities) (IPCC 2006, V2, Ch5).

The emissions from the various CCS steps are to be reported separately. Emissions estimation methods are provided only for geological storage, and not for other storage options such as ocean storage or conversion of CO<sub>2</sub> into inert inorganic carbonates.

During the CCS process, emissions resulting from fossil fuels used for capture, compression, transport, and injection of CO<sub>2</sub> are also produced. Emissions from these fossil fuels are not incorporated in this IPCC category, but rather in the energy use category: either stationary or mobile energy use categories.

The sources covered within this category are detailed in the table below, however companies which carry out CCS may have emissions which fall within other categories of the IPCC Guidelines as well, such as stationary combustion emissions, when it is not related to the CCS activity. Please refer to Section 3 "Reporting Sectors" of this report for further guidance on the other potential emission sectors which may be relevant.

### 25.1. IPCC Classification

Table 25:1: IPCC Classification of emissions for Carbon Capture and Storage

Sector	Relevant IPCC code/s	Definition	Relevant IPCC Gases	Tier	Methodology reference	Transitional arrangements
Carbon Capture and Storage	1C	Carbon dioxide (CO <sub>2</sub> ) capture and storage (CCS) involves the capture of CO <sub>2</sub> from anthropogenic sources, its transport to a storage location and its long-term isolation from the atmosphere. Emissions associated with CO <sub>2</sub> transport, injection	CO <sub>2</sub>	2 or 3	Section 25	Yes

		and storage are covered under category 1C.				
1A1c		Combustion emissions from energy production. (i.e. combustion emissions from fossil-fuel driven pumping stations)	CO <sub>2</sub>	Tier 2 or 2	Section 12	Yes
			CH <sub>4</sub>	Tier 1, 2 or 3	Section 12	No
			N <sub>2</sub> O	Tier 1, 2 or 3	Section 12	No

(Source: IPCC 2006 Volume 2, Chapters 2 & 5)

\* These emissions may comprise fugitive losses due to equipment leaks, venting and releases due to pipeline ruptures or other accidental releases.

Please note that the table above details the sectors that should be covered as a minimum. If there are other emission sources, under control of the data provider, that still need to be reported please report them under the relevant categories as listed in 23 of this document.

## 25.2. Methodology

### Method 1: IPCC Tier 3 approach

Only a site-specific Tier 3 approach is used to quantify emissions from CCS. Tier 1 and Tier 2 methodologies are not available for CCS.

There are various requirements for the quantification of emissions released during CCS. The requirements include CCS site characterisation, emissions modelling, assessment of the risk of emissions leakage as well as actual emissions monitoring.

## 25.3. Activity data

Activity data for the quantification of leakage emissions from CCS is actual emissions measured using continuous emissions measurement (CEM) technology.

## 25.4. Emission Factors

As the leakage emissions from CCS are estimated by either modelling or by actual measurement, no emission factors are required.

## 26. Cement Production

Cement production emissions result from the production of clinker, an intermediate product. During the production of clinker, limestone, which is mainly calcium carbonate ( $\text{CaCO}_3$ ), is heated, or calcined, to produce lime ( $\text{CaO}$ ) and  $\text{CO}_2$  as a by-product. Presence of other carbonates in the cement raw material,  $\text{CaCO}_3$ , is usually quite low.

Due to the multi-faceted nature of cement production, cement producing companies should be aware that additional activities for reporting should fall under additional IPCC subsectors such as stationary combustion of carbonaceous fuel sources (1A2f). Therefore, companies should calculate emissions from those activities as described in Annexure 1.

### 26.1. IPCC Classification

The direct emissions associated with cement production are related to the IPCC source categories for the GHG Reporting Regulations.

Table 26.1: IPCC classification of emissions for cement production

Sector	Relevant IPCC code/s	Definition	Relevant IPCC Gases	Tier	Methodology reference	Transitional arrangements
Cement Production	1A2f	Fuel combustion activities in the non-metallic minerals sector.	$\text{CO}_2$	1, 2 or 3	Section 12	Yes
			$\text{CH}_4$	1, 2 or 3	Section 12	No
			$\text{N}_2\text{O}$	1, 2 or 3	Section 12	No
	2A1	Cement production process emissions.	$\text{CO}_2$	2 or 3	Section 26	Yes

Please note that the table above details the sectors that should be covered as a minimum. If there are other emission sources, under control of the data provider, that still need to be reported, please report them under the relevant categories as listed in Table 5.2 of this document.

### 26.2. Methodology

#### Method 1&2: IPCC tier 1 and tier 2 methodology

It is good practice to estimate emissions based on clinker production, the Tier 2 approach. If direct clinker production data are not available, inferred clinker production figures can be estimated using cement production data, the Tier 1 approach.

In estimating emissions based on inferred clinker production estimates from cement production data, correcting for imports and exports of clinker must be made to avoid overestimation or underestimation of emissions.

In some cases, cement kiln dust (CKD) may be generated during the manufacture of clinker, and emission estimates should account for emissions associated with the CKD.

$$\text{CO}_2 \text{ Emissions} = \text{Mcl} \cdot \text{EFcl} \cdot \text{CFckd}/1000$$

Where:

CO<sub>2</sub> Emissions = emissions of CO<sub>2</sub> from cement production, tonnes

Mcl = weight (mass) of clinker produced tonnes

EFcl = emission factor for clinker, tonnes CO<sub>2</sub>/tonne clinker (not corrected for CKD.

See 2006 IPCC GHG Guidelines Table 2.2)

CFckd = emissions correction factor for CKD, dimensionless (see Tier 1 Equation)

A factor of 1000 is used to convert from tonnes to Gigagrams of the relevant Greenhouse gas.

### Method 3: IPCC Tier 3 methodology

The Tier 3 approach is a calculation based on the weights and compositions of all carbonate inputs from all raw material and fuel sources, the emission factor(s) for the carbonate(s), and the fraction of calcination achieved. The Tier 3 approach relies on plant specific data.

In using Tier 2, the following information/questions need to be addressed for each cement plant;

- i. Is the main source of clinker at the plant CaCO<sub>3</sub>? Are there other fractions of CaO from a non-carbonate source such as steel slag or fly ash? If yes, what is the percentage of CaO from non-carbonate sources?
- ii. Is there a CO<sub>2</sub> capture technology installed and used at the plant?
- iii. What was the amount of clinker produced each year?
- iv. Is the plant able to control the CaO content of the raw material inputs and of the clinker within close tolerances? What is the CaO composition of clinker (generally within range 60 to 67 percent)? Is it stable? (i.e. does it remain stable to within 1 to 2 percent)
- v. Could it be said that a 100 per cent (or very close to it) calcination factor is achieved for the carbonate inputs for clinker manufacture, including (commonly to a lesser degree) material lost to the system as non-recycled CKD?
- vi. Are there dust collectors at the plant to capture essentially all the CKD?
- vii. Can a separation of calcined and uncalcined CKD be made? Is the calcined CKD recycled to the kiln or disposed?

**26.3. General requirements for sampling cement clinker**

- (1) A sample of cement clinker must be derived from a composite of amounts of the cement clinker produced.
- (2) The samples must be collected on enough occasions to produce a representative sample.
- (3) The samples must also be free of bias so that any estimates are neither over nor underestimates of the true value.
- (4) Bias must be tested in accordance with an appropriate standard.
- (5) The value obtained from the sample must only be used for the production period for which it was intended to be representative.

**26.4. General requirements for analysing cement clinker**

- (1) Analysis of a sample of cement clinker, including determining the fraction of the sample that is calcium oxide or magnesium oxide, must be done in accordance with industry practice.
- (2) The minimum frequency of analysis of samples of cement clinker must be in accordance with the Tier 3 method for cement clinker in section 2.2.1.1 in Chapter 2 of Volume 3 of the 2006 IPCC Guidelines.

**26.5. Activity Data**

Activity data requirements for calculation of emissions from cement production are summarised in the table below.

Table 26:2: Cement emission data requirements

Emission Sector	Emission Source	Data required		
		Tier 1	Tier 2	Tier 3
Industrial processes	Cement production emissions	<ul style="list-style-type: none"> <li>- Quantity of cement production by type</li> <li>- Clinker import/exports into South Africa</li> <li>- Clinker/cement ratio by type of cement</li> <li>- CaO content of clinker (indicate if default values were used)</li> <li>- Cement kiln dust losses</li> </ul>	<ul style="list-style-type: none"> <li>- Clinker production and CaO content of clinker;</li> <li>- Clinker import/exports into South Africa</li> <li>- Data on non-carbonate feeds to kiln;</li> <li>- Cement kiln dust losses</li> </ul>	<ul style="list-style-type: none"> <li>- Disaggregated data on the types (compositions) and quantities of carbonate(s) consumed to produce clinker</li> <li>- Emission factor(s) of the carbonate(s) consumed.</li> </ul>

**26.6. Emission Factors**

For details on emission factors please refer to section 2.2.1.2 of Volume 3, Chapter 2 of the 2006 IPCC Guidelines.

## 27. Lime Production

The heating of limestone and the consequential decomposition of carbonates produces calcium oxide (CaO or quicklime). The process is usually carried out in a kiln at high temperatures, with GHG emissions released. These are classified as process emissions. Emissions from the processing of dolomite or dolomitic limestone to produce dolomitic lime is also reported under this section, as well as the production of hydrated (slaked) lime. During the production of lime, lime kiln dust (LKD) may be generated. Emissions from the LKD are also estimated within this category.

There is a specific category within the 2006 IPCC Guidelines in which lime producing companies should report their direct emissions related to lime production, "2A2 Lime Production". Emissions from both marketed and/or non-marketed lime product are reported under this IPCC category. These emissions are referred to as process emissions.

Lime producing companies should be aware that emissions from other activities at a lime production facility should fall under additional IPCC sectors, such as stationary combustion of carbonaceous fuel sources (1A2f). Therefore, companies should calculate emissions from those activities as described in the relevant sections of Annexure 1.

The specific methodology to determine the emissions associated with lime production is detailed in Volume 3, Chapter 2.3 of the 2006 IPCC guidelines.

### 27.1. IPCC Classification

Companies with lime production facilities must report stationary combustion and process emissions from each lime process plant.

The table below details the IPCC source categories for lime production.

Table 27:1: IPCC classification of emissions for lime production

Sector	Relevant IPCC code/s	Definition	Relevant IPCC Gases	Tier	Methodology reference	Transitional arrangements
Lime Production	1A2f	Fuel combustion activities in the non-metallic minerals sector.	CO <sub>2</sub>	2 or 3	Section 12	Yes
			CH <sub>4</sub>	1, 2 or 3	Section 12	No
			N <sub>2</sub> O	1, 2 or 3	Section 12	No
	2A2	Lime production process emissions.	CO <sub>2</sub>	2 or 3	Section 27	Yes

Please note that the table above details the sectors that should be covered as a minimum. If there are other emission sources, under control of the data provider, that still need to be



reported please report them under the relevant categories as listed in Table 5:2 of this document.

## 27.2. Methodology

Three approaches are available for emission estimation from lime production. The Tier 1 approach is a simple method based on applying a default emission factor to national level lime production data.

### Method 1: IPCC Tier 1 methodology

The Tier 1 method is based on applying a default emission factor to national level lime production data. It is important to obtain lime production by type. LKD does not need to be accounted for under this approach.

$$EF_{\text{Lime}} = 0.85 \times EF_{\text{high calcium lime}} + 0.15 \times EF_{\text{dolomite lime}}$$

(The default EF for dolomitic lime may be 0.86 or 0.77, see 2006 IPCC Guidelines Volume 3, Chapter 2, Table 2.4)

$$= 0.75 \text{ tonnes CO}_2 / \text{tonne lime produced}$$

### Method 2: IPCC Tier 2 methodology

The Tier 2 approach requires country-specific information on the proportion of hydrated lime produced. A correction of lime kiln dust (LKD) is required when using the Tier 2 approach. Please refer to section 2.2.1.1 of Volume 3, Chapter 2 of the 2006 IPCC Guidelines.

### Method 3: IPCC Tier 3 methodology

The Tier 3 approach is based on the collection of plant-specific data on the types and quantities of carbonate(s) consumed, as well as a correction for LKD. Please refer to section 2.2.1.1 of Volume 3, Chapter 2 of the 2006 IPCC Guidelines.

## 27.3. Activity Data

Some industries produce lime and consume it for their own operations. Both marketed and non-marketed lime production would form part of the activity data.

Table 27:2: Lime Production emission activity data

Tier 1	Tier 2	Tier 3	Other information
i) Quantity of lime production by type per annum (high calcium lime, dolomitic lime, or hydraulic lime)	i) Quantity of Lime production by type per annum ii) Data on non-carbonate feeds to kiln iii) Lime kiln dust losses	i) Disaggregated data on the types (compositions) and quantities of carbonate(s) consumed to produce lime ii) Emission factor(s) of the carbonate(s) consumed iii) Calcination level achieved	i) Implemented GHG emission abatement measures and estimates of abatement ii) Plant specific GHG emission factors, if available iii) Information on data quality and uncertainty estimates

#### 27.4. Emission Factors

The choice of emission factors depends on the approach used. For example, the Tier 1 approach uses an emission factor for the total quantity of lime produced. The Tier 2 emission factor is similar to Tier 1 but takes into consideration the stoichiometric ratios between CO<sub>2</sub> and CaO and/or CaO·MgO, and an adjustment to account for the CaO or the CaO·MgO content of the lime.

For Tier 3 the emission factors are based on the actual carbonates present, presenting a full accounting of carbonates (species and sources) and may include a correction (namely, a subtraction) for un-calcined lime kiln dust.

For details on emission factors please refer to section 2.3.1.2 of Volume 3, Chapter 2 of the 2006 IPCC Guidelines.

## 28. Glass Production

Glass production can be divided into four main categories, namely: containers, flat glass, fibre glass and speciality glass.

Glass raw materials which emit CO<sub>2</sub> during the melting process are limestone (CaCO<sub>3</sub>), dolomite (calcium magnesium carbonate) CaMg(CO<sub>3</sub>)<sub>2</sub> and soda ash (Na<sub>2</sub>CO<sub>3</sub>). Other glass raw materials that produce minimal amounts of CO<sub>2</sub> are barium carbonate (BaCO<sub>3</sub>), bone ash (3CaO<sub>2</sub>P<sub>2</sub>O<sub>5</sub> + XCaCO<sub>3</sub>), potassium carbonate (K<sub>2</sub>CO<sub>3</sub>) and strontium carbonate (SrCO<sub>3</sub>).

The fusion of glass is a complex high temperature chemical reaction and should not be compared to the calcination of carbonates to produce quicklime or burnt dolomitic lime. However, the fusion has the same net effect in terms of CO<sub>2</sub> emissions. The methodology to determine the emissions associated with glass production is detailed in Volume 3, Chapter 2.4 of the 2006 IPCC guidelines.

In addition to these raw materials listed above, glass is also produced from a certain amount of cullet (recycled glass material). In general, most glass producers use as much cullet as they can obtain, sometimes with restrictions imposed by glass quality requirements. The cullet ratio is referred to as the fraction of the furnace charge represented by cullet and is normally in the range of 0.4 to 0.6 for container glass applications.

### 28.1. IPCC Classification

The table below details the relationship between direct emission sources and the IPCC classification as per the Regulations.

**Table 28:1: IPCC classification of emissions for glass production**

Sector	Relevant IPCC code/s	Definition	Relevant IPCC Gases	Tier	Methodology reference	Transitional arrangements
Glass Production	1A2f	Fuel combustion activities in the non-metallic minerals sector.	CO <sub>2</sub>	2 or 3	Section 12	Yes
			CH <sub>4</sub>	1, 2 or 3	Section 12	No
			N <sub>2</sub> O	1, 2 or 3	Section 12	No
	2A3	Glass production process emissions.	CO <sub>2</sub>	2 or 3	Section 28	Yes

Please note that the table above details the sectors that should be covered as a minimum. If there are other emission sources under control of the data provider that still need to be reported, please report them under the relevant categories as listed in Table 5:2 of this document.

## 28.2. Methodology

### Method 1: IPCC Tier 1 methodology

A Tier 1 methodology assumes the following 'typical' soda-lime batch: sand (56.2 weight per cent), feldspar (5.3 per cent), dolomite (9.8 per cent), limestone (8.6 per cent) and soda ash (20.0 per cent). Based on this composition, one metric tonne of raw materials yields approximately 0.84 tonnes of glass, losing about 16.7 percent of its weight as volatiles, in this case virtually entirely CO<sub>2</sub>. Hence, the default Tier 1 emission factor for glass production is calculated as follows:  $EF = 0.167 / 0.84 = 0.20$  tonnes CO<sub>2</sub> / tonne glass.

$$\text{CO}_2 \text{ Emissions} = (M_g \cdot EF \cdot (1 - CR)) / 1000$$

Where:

CO<sub>2</sub> Emissions = emissions of CO<sub>2</sub> from glass production, tonnes

M<sub>g</sub> = weight (mass) of glass produced, tonnes

EF = default emission factor for manufacturing of glass, tonnes CO<sub>2</sub>/tonne glass. See 2006 IPCC GHG Guidelines, Equation 2.13)

CR = cullet ratio for process (either national average or default), fraction

A factor of 1000 is used to convert from tonnes to Gigagrams of the relevant Greenhouse gas.

### Method 2: IPCC Tier 2 methodology

The Tier 2 method relies on applying default emission factors and cullet ratios to the various types of glass produced in the country (2006 IPCC Guidelines, Volume 2, Table 2.6). Where country specific or even plant specific data are available countries are encouraged to use these data to supplement or replace the defaults provided below. Cullet ratios, in particular, can vary significantly both within a country and across countries.

### Method 3: IPCC Tier 3 methodology

The Tier 3 approach accounts for the carbonate input into the glass melting furnace. This would be based on the site- specific chemistry of raw materials. If site-specific raw materials data are used, it is vital that all sources of carbonate in the raw materials and fuels are accounted for (not just the limestone).

## 28.3. Activity Data

Activity data for the Tier 1 method includes glass production by weight as well as a correction for the quantity of cullet used in glass production. Tier 1 assumes a default cullet ratio of 50 per cent, therefore national level data on the mass of glass produced can be multiplied by  $0.20 \cdot (1 - 0.50) = 0.10$  tonnes CO<sub>2</sub>/tonne glass in order to estimate national emissions.

The Tier 2 method requires, at a minimum, the collection of national level data on the quantity of glass melted in the manufacturing process. Data for glass often is provided in different units (e.g., tonnes of glass, number of bottles, square meters of glass, etc.) and these should be converted into tonnes.

The Tier 3 method requires collection of plant-level activity data on the various types of carbonates consumed for glass production.

**Table 28:2: Glass production emissions data requirements**

<b>Tier 1</b>	<b>Tier 2</b>	<b>Tier 3</b>	<b>Other information</b>
i) Quantity of glass production per annum ii) Quantity of glass recycles for new glass production	i) Quantity of melted glass of a given type (e.g., float, container, fibre glass, etc.) per annum ii) Quantity of glass recycles for new glass production	i) Quantity and details of different types of carbonates used in producing glass ii) Calcination level achieved for each type of used carbonates	i) Implemented GHG emission abatement measures and estimates of abatement ii) Plant specific GHG emission factors iii) Amount of other carbonates, e.g. soda ash iv) Information on data quality and uncertainty estimates

#### **28.4. Emission Factors**

The Tier 1 method applies a default emission factor based on the typical raw material mixture from national glass production data. This default factor is 0.2 tonnes CO<sub>2</sub> /tonne glass produced locally (Equation 2.13 of Volume 3 Chapter 2 of the 2006 IPCC guidelines).

The Tier 2 method applies default emission factors and cullet ratios to the various types of glass manufactured as follows:

Table 28:3: Default emission factors and cullet ratios for different types of glass<sup>14</sup>

Glass Type	CO <sub>2</sub> Emission Factor (kg CO <sub>2</sub> /kg glass)	Cullet Ratio (typical range)
Float	0.21	10% - 25%
Container (Flint)	0.21	30% - 60%
Container (Amber/Green)	0.21	30% - 80%
Fiberglass (E-glass)	0.19	0% - 15%
Fiberglass (Insulation)	0.25	10% - 50%
Specialty (TV Panel)	0.18	20% - 75%
Specialty (TV Funnel)	0.13	20% - 70%
Specialty (Tableware)	0.10	20% - 60%
Specialty (Lab/Pharma)	0.03	30% - 75%
Specialty (Lighting)	0.20	40% - 70%
Source: Communication with Victor Aume (2004)		

The Tier 3 method emission factors are based on actual carbonates consumed in the melting furnace and require full accounting of carbonates (species and sources).

<sup>14</sup> If available, company-specific cullet ratios should be used instead of the default values. A data provider must demonstrate that the cullet ratios are based on production statistics of the amount of recycled glass used over a calendar year period.

## 29. Other Process Uses of Carbonates

In addition to the carbonates processes described above, (cement production, lime production and glass production), carbonates also are consumed in metallurgy (e.g., iron and steel), agriculture, construction, and environmental pollution control (e.g., flue gas desulphurisation.) It is good practice to report emissions from the consumption of carbonates in the source category where the carbonates are consumed, and the CO<sub>2</sub> is emitted. Under this section, four broad source categories are considered: (1) ceramics, (2) other uses of soda ash, (3) non-metallurgical magnesia production, and (4) other uses of carbonates.

### 29.1. Ceramics production emissions

Ceramics include the production of bricks and roof tiles, vitrified clay pipes, refractory products, expanded clay products, wall and floor tiles, table and ornamental ware (household ceramics), sanitary ware, technical ceramics, and inorganic bonded abrasives. Emissions from ceramics result from the calcination of carbonates in the clay, as well as the addition of additives.

### 29.2. IPCC Classification

The table below details the relationship between direct emission sources and the IPCC classification as per the Regulations.

**Table 29:1: IPCC classification of emissions for glass production**

Sector	Relevant IPCC code/s	Definition	Relevant IPCC Gases	Tier	Methodology reference	Transitional arrangements
Ceramics Production	1A2f	Fuel combustion activities in the non-metallic minerals sector.	CO <sub>2</sub>	2 or 3	Section 12	Yes
			CH <sub>4</sub>	1, 2 or 3	Section 12	No
			N <sub>2</sub> O	1, 2 or 3	Section 12	No
	2A4a	Ceramics production process emissions.	CO <sub>2</sub>	2 or 3	Section 29	Yes

Please note that the table above details the sectors that should be covered as a minimum. If there are other emission sources under control of the data provider that still need to be reported, please report them under the relevant categories as listed in Table 5:2 of this document.

### 29.3. Methodology

#### Method 1: IPCC Tier 1 methodology

A Tier 1 methodology assumes that only limestone and dolomite is used as a carbonate input in industry. A default fraction of limestone vs dolomite consumed is used to estimate emissions. Data needs to reflect pure carbonates and not carbonate rock. If data is only available on carbonate rock, a default purity of 95 percent can be assumed. For clays a default carbonate content of 10 percent can be assumed if no other information is available.

#### Method 2: IPCC Tier 2 methodology

The Tier 2 method, similar to the Tier 1 approach assumes only limestone and dolomite are used as carbonate input, however the approach requires country specific information on the fraction of limestone vs dolomite consumed.

#### Method 3: IPCC Tier 3 methodology

**The Tier 3 approach accounts for all emissive uses of carbonates (**

Table 29:4). This would be based on the site- specific chemistry of raw materials. If site-specific raw materials data are used, it is vital that all sources of carbonate in the raw materials and fuels are accounted for (not just the limestone).

### 29.4. Activity Data

Activity data for the Tier 1 method includes total carbonate consumption for emissive uses . In the absence of better data, it is consistent with good practice for inventory compilers to assume that 85 percent of carbonates consumed are limestone and 15 percent of carbonates consumed are dolomite.

The Tier 2 method requires the total quantity of carbonates consumed at each end use sector. Should the data not be available, it is good practice to collect data at a national level of the total quantity of limestone and dolomite consumed. As with Tier 1, should the fraction of calcination not be known, the compiler may assume 100 percent calcination has been achieved.

The Tier 3 approach requires plant-level carbonate consumption from that source category as well as fraction of calcination achieved. As with Tier 1 and 2 should the fraction of calcination not be known, the compiler may assume 100 percent calcination has been achieved. Where clay is used the compiler should collect clay consumption data for all relevant ceramics products.



**29.5. Emission Factors**

The Tier 1 and 2 method is based on the mass of CO<sub>2</sub> released per mass of carbonate consumed (Table 29:2). The distinction is based on the activity data.

**Table 29:2: Formulae, Formula Weights, and Carbon Dioxide Contents of Common Carbonate Species\***

Carbonate	Mineral Name(s)	Formula Weight	Emission Factor (tonnes CO <sub>2</sub> /tonne carbonate) **
CaCO <sub>3</sub>	Calcite*** or aragonite	100.0869	0.43971
MgCO <sub>3</sub>	Magnesite	84.3139	0.52197
CaMg(CO <sub>3</sub> ) <sub>2</sub>	Dolomite***	184.4008	0.47732
FeCO <sub>3</sub>	Siderite	115.8539	0.37987
Ca(Fe,Mg,Mn)(CO <sub>3</sub> ) <sub>2</sub>	Ankerite****	185.0225 – 215.6160	0.40822 – 0.47572
MnCO <sub>3</sub>	Rhodochrosite	114.9470	0.38286
Na <sub>2</sub> CO <sub>3</sub>	Sodium carbonate or soda ash	106.0685	0.41492

Source: CRC Handbook of Chemistry and Physics (2004)  
 \*Final results (i.e. emission estimates) using these data should be rounded to no more than two significant figures.  
 \*\* The fraction of emitted CO<sub>2</sub> assuming 100 percent calcination; e.g., 1 tonne calcite, if fully calcined, would yield 0.43971 tonnes of CO<sub>2</sub>.  
 \*\*\* Calcite is the principal mineral in limestone. Terms like high-magnesium or dolomitic limestones refer to a relatively small substitution of Mg for Ca in the general CaCO<sub>3</sub> formula commonly shown for limestone.  
 \*\*\*\* Formulae weight range shown for ankerite assumes that Fe, Mg, and Mn are present in amounts of at least 1.0 percent.

The Tier 3 emission factor represents the weighted average of the emission factors of the individual carbonates (Table 29.2). The Tier 3 approach requires the full accounting of carbonates (species and sources).

Note: Brick Manufacturing Plants – Should a plant meet the threshold of IPCC activity 2A4a but uses raw materials (e.g., clay) that do not contain carbonates, the data provider is required to register on SAGERS regardless and provided us with under Attachments on the SAGERS report a monthly or annual summary of lab analysis undertaken on the raw material (e.g. clay) being used. An example of the analysis to be taken is shown below in Figure 29:1.

Major element analysis (wt%) concentrations were determined by X-Ray Fluorescence Spectrometry (XRF) on fusion discs. 12/76 is a secondary amphibolite reference material.

Sample	BF-4	BF-10	BFB1-dark	BFB1-light	BFS-1	BFW-1	CHB-1	CHN-1	CHY-1	GWB-1	MF-1	12/76	
												Certified	Result
SiO <sub>2</sub>	70.70	62.24	68.15	68.62	58.56	69.30	58.80	55.24	54.87	60.63	68.67	45.42	45.24
TiO <sub>2</sub>	0.83	0.79	0.75	0.86	0.74	0.92	0.91	0.84	0.80	0.93	0.80	1.54	1.57
Al <sub>2</sub> O <sub>3</sub>	17.97	24.85	16.63	16.87	20.10	19.16	26.27	18.37	20.34	25.50	20.74	16.62	16.45
Fe <sub>2</sub> O <sub>3</sub> (t)	1.61	1.16	4.65	4.57	8.46	1.30	1.39	16.08	13.39	1.93	1.08	9.73	9.93
MnO	0.002	0.005	0.010	0.022	0.140	0.004	0.005	<0.001	0.014	0.002	0.002	0.180	0.176
MgO	0.43	0.30	0.96	0.76	0.96	0.44	0.25	0.23	0.21	0.24	0.13	8.15	8.17
CaO	0.04	0.06	0.12	0.09	0.35	0.05	0.07	0.49	0.57	0.09	0.02	10.93	10.83
Na <sub>2</sub> O	0.28	0.31	1.27	0.34	0.65	0.20	0.86	0.45	0.50	0.98	0.12	3.65	3.69
K <sub>2</sub> O	2.88	4.50	3.12	3.12	2.33	3.39	3.03	1.81	2.14	2.97	2.65	0.70	0.69
P <sub>2</sub> O <sub>5</sub>	0.115	0.118	0.091	0.046	0.111	0.048	0.122	0.213	0.316	0.232	0.059	0.259	0.254
Cr <sub>2</sub> O <sub>3</sub>	0.017	0.016	0.014	0.018	0.020	0.014	0.020	0.023	0.021	0.020	0.017	0.074	0.078
L.O.I.	4.92	5.42	4.03	4.50	7.39	4.92	7.89	6.12	6.66	6.20	5.49	2.50	2.64
Total	99.79	99.79	99.79	99.82	99.81	99.76	99.61	99.88	99.82	99.72	99.78	99.75	99.72
H <sub>2</sub> O'	0.82	0.60	0.95	0.64	1.35	0.50	1.15	0.88	0.82	0.91	0.52	0.18	0.11

Figure 29:1: Example of chemical analysis to be undertaken

**29.6. Emissions from Other uses of Soda Ash**

Soda ash production and consumption (including sodium carbonate, Na<sub>2</sub>CO<sub>3</sub>) results in the release of CO<sub>2</sub>. Emissions from soda ash production are reported in the Chemical Industry section, while emissions from use are reported in the respective end use sectors where soda ash is used. Emissions from soda ash used in glass production are already accounted for under glass production emissions.

**29.7. Non Metallurgical Magnesia production emissions**

Emission of CO<sub>2</sub> results from the calcining of magnesite (MgCO<sub>3</sub>). This source category should include emissions from magnesia (MgO) production that are not included elsewhere. For example, where magnesia is produced for use as a fertiliser, good practice is to report those emissions under Chemical Industry Emissions.

**29.8. Other uses of carbonates**

Included here are emissions that may result from a number of other source categories that are not included above. In allocating to this source category, one should be careful to not double count emissions already recorded in other source categories.

Mainly Tier 1 and Tier 2 methods can be used to estimate emissions from other process use of carbonates. The Tier 1 method assumes that only limestone and dolomite are used as carbonate input in industry, and allows for the use of a default fraction of limestone versus dolomite consumed in the process. Tier 2 goes further to include country specific information on the fraction of limestone versus dolomite consumed. If the Tier 3 method is used, it is important that all carbonate inputs are considered in the analysis.

**Table 29:3: Users of Limestone (CaCO<sub>3</sub>), dolomite (CaMg(CO<sub>3</sub>)<sub>2</sub>) and other carbonates (e.g., MgCO<sub>3</sub> and FeCO<sub>3</sub>) (including ceramics, soda ash users, non-metallurgical magnesia production, and others)**

Tier 1	Other information
i) Quantity of carbonates consumed, by type, per annum ii) Percentage purity of carbonates used	i) Specific consumptions of limestone or dolomite, separate from total carbonates used ii) If specific information on GHG emission abatement measures and estimates of abatement iii) Plant specific GHG emission factors iv) Information on data quality and uncertainty estimates

The following table, from the 2006 IPCC GHG Guidelines, provides possible carbonate consumption activities that could be emissive.

Table 29:4: Possible emissive Uses of Carbonates

<b>Emissive and Non-Emissive Uses of Carbonates</b>		
<b>Where are Carbonates Consumed? Is source:</b>	<b>Emissive?</b>	<b>If yes, where should emissions be reported</b>
<i><b>Agricultural:</b></i>		
Agricultural limestone	Yes*	AFOLU: 3C2 Liming
Poultry grit and mineral food	No	
Other agricultural	No	
<i><b>Chemical and metallurgical:</b></i>		
Cement manufacture	Yes	IPPU: 2A1 Cement Production
Lime manufacture	Yes	IPPU: 2A2 Lime Production
Dead burning of dolomite	Yes	IPPU: 2A2 Lime Production, where dead burned; outside of lime industry under Other (2A4d).
Flux stone	Yes	IPPU: 2C Metal Industry, industry where consumed; unless counted within Energy (for combustible off-gases sold off-site)
Chemical stone	Yes**	Source category where consumed
Glass manufacture	Yes	IPPU: 2A3 Glass Production
Sulphur oxide removal	Yes*	Source category where consumed
Fertilisers	Yes**	IPPU: 2B Chemical Industry
<i><b>Ceramics and mineral wool:</b></i>		
Ceramics	Yes	Mineral Industry: 2A4a Ceramics
Mineral wools	Yes	IPPU: Mineral Industry: 2A3 Glass Production or 2A4d Other, depending on production process.
<i><b>Special:</b></i>		
Mine dusting or acid water treatment	Yes	Source category where consumed
Asphalt fillers or extenders	No	
Whiting or whiting substitute	No	
Other fillers or extenders	No	
<i><b>Construction:</b></i>		
Use as a Fine or Coarse Aggregate	No	
<i><b>Other miscellaneous uses:</b></i>		
Refractory stone	No	
Acid neutralisation	Yes*	Source category where consumed
Chemicals	No	

Emissive and Non-Emissive Uses of Carbonates		
Where are Carbonates Consumed? Is source:	Emissive?	If yes, where should emissions be reported
Paper manufacture	No	
Abrasives	No	
Sugar refining	Yes	IPPU: Emissions from lime production at sugar mills should be reported under 2A2 Lime Production; all other emissions in 2A4 Other Process Uses of Carbonates. Removals should be reported under 2H2 Food and Beverages Industry.
<i>Others</i>	Yes*, No	Where Yes, IPPU: 2A4 Other Process Uses of Carbonates
* Emissions are by an acidification reaction. ** Emissions could be by calcination and/or acidification.		

### 30. Ammonia Production

Ammonia production refers to the production of ammonia from carbon monoxide rich gas streams derived from fossil fuel feedstocks, noticeably reformed natural gas, coal derived synthetic gas or the associated downstream tail gas. The synthesis of the ammonia is based on the water shift reaction whereby carbon monoxide in the presence of water reacts to form carbon dioxide and hydrogen. The produced hydrogen is brought into contact with nitrogen via the Haber-process to produce ammonia. Ammonia is used directly as a fertiliser, in heat treating, paper pulping, nitric acid and nitrates manufacture, nitric acid ester and nitro compound manufacture, explosives of various types, and as a refrigerant. Urea is also made from ammonia.

Ammonia is produced by using oil or natural gas as feedstock. Care should therefore be given to ensure the natural gas feedstock used in production of ammonia is not included in the energy sector emissions. To avoid double counting, the total quantities of oil or gas used (fuel plus feedstock) in ammonia production must be subtracted from the quantity reported under energy use in the energy sector. The methodology to determine the emissions associated with ammonia production is detailed in Volume 3, Chapter 3 of the 2006 IPCC guidelines.

#### 30.1. IPCC Classification

The table below details the relationship between direct emission sources and the IPCC classification as per the Regulations.

**Table 30:1: IPCC classification of emissions for Ammonia Production**

Sector	Relevant IPCC code/s	Definition	Relevant IPCC Gases	Tier	Methodology reference	Transitional arrangements
Ammonia Production	1A2c	Fuel combustion activities in the chemicals sector.	CO <sub>2</sub>	2 or 3	Section 12	Yes
			CH <sub>4</sub>	1, 2 or 3	Section 12	No
			N <sub>2</sub> O	1, 2 or 3	Section 12	No
	2B1 <sup>15</sup>	Ammonia production process emissions.	CO <sub>2</sub> + (CH <sub>4</sub> - optional)	2 or 3	Section 30	Yes

Please note that the table above details the sectors that should be covered as a minimum. If there are other emission sources, under control of the data provider, that still need to be reported please report them under the relevant categories as listed in Table 5:2 of this document.

<sup>15</sup> Please note that if a non-conventional process is used to produce Ammonia (e.g. in the case of SASOL), then a material (carbon) balance showing all the input, output and waste streams should be used to quantify CO<sub>2</sub> emissions from non-conventional ammonia production. In addition, the amount of fuel (e.g. natural gas) used as feedstock to produce Ammonia should be reported to DFFE separately and not included in the quantity of fuels used for combustion purposes in the energy sector.

### 30.2. Methodology

#### Method 1: IPCC Tier 1 methodology — ammonia production (production output based)

The Tier 1 method is based on default values and ammonia production data is used to derive emissions, as shown below;

$$E_{CO_2} = [AP \cdot FR \cdot CCF \cdot COF \cdot 44/12 - R_{CO_2}]/1000000$$

Where:

- $E_{CO_2}$  = emissions of CO<sub>2</sub>, kg  
 AP = ammonia production, tonnes  
 FR = fuel requirement per unit of output, GJ/tonne ammonia produced  
 CCF = carbon content factor of the fuel, kg C/GJ  
 COF = carbon oxidation factor of the fuel, fraction  
 $R_{CO_2}$  = CO<sub>2</sub> recovered for downstream use (urea production), kg

A factor of 1000 000 to convert from kilograms to Gigagrams of the relevant Greenhouse gas

#### Method 2: IPCC Tier 2 methodology — ammonia production (input material based)

The Tier 2 methodology for deriving emissions of carbon dioxide released from the use of fuels as feedstocks in the production of ammonia is shown below:

$$E_{ij} = [Q_i \times EC_i \times EF_{ij} \times (44/12) - R]/1000$$

Where:

$E_{ij}$  is the emissions of carbon dioxide released from the production of ammonia during the year measured in CO<sub>2</sub>e tonnes.

$Q_i$  is the quantity of each type of feedstock/fuel ( $j$ ) consumed from the production of ammonia during the year, measured in (tonnes).

$EC_i$  is the energy content factor for fuel type ( $i$ ) used as a feedstock in the production of ammonia during the year (GJ/tonne).

$EF_{ij}$  is the carbon dioxide emission factor for each type of feedstock/fuel ( $j$ ) used in the production of ammonia during the year, including the effects of oxidation, measured in kilograms for each gigajoule (kgC/GJ). If using carbon content, multiply by 44/12 to convert from carbon-to-carbon dioxide.

$R$  is the quantity of carbon dioxide measured in CO<sub>2</sub>e tonnes derived from the production of ammonia during the year, captured and transferred for use in the operation of another facility such as urea production (kg).

**Method 3: IPCC Tier 3 methodology — ammonia production (input material based)**

Tier 3 methodology is similar to the Tier 2 methodology. The difference is that the Tier 3 methodology uses plant-specific total fuel requirements (fuel plus feedstock) and emission factors for ammonia production (per tonne NH<sub>3</sub>).

**30.3. Activity Data**

For details on choice of activity data please refer to section 3.2.2.3 in Volume 3 Chapter 3 of the 2006 IPCC Guidelines.

**Table 30:2: Choice of Activity data**

Tier 1/2	Other information
i) Quantity of ammonia produced per annum for each fuel type ii) Fuel requirement per unit of output, GJ/tonne ammonia produced iii) Quantity of fuel used, by type, per annum	i) Implemented GHG emission abatement measures, or any CO <sub>2</sub> recovered and estimates of abatement ii) Quantity of urea produced, where CO <sub>2</sub> recovered for downstream the production iii) Information on data quality and uncertainty estimates

Please note that the amount of natural gas used for production of natural gas should be reported. This will ensure that over-allocation of natural gas in the energy sector is avoided.

**30.4. Emission Factors**

**Method 2: IPCC Tier 1 methodology – ammonia production**

In this approach, should plant-specific information not be available, it is good practice to use default factors. For the Tier 1 method it is good practice to use the highest total fuel requirement per tonne of ammonia. If no information on fuel type is available, it is good practice to use the average value shown in

Table 30:3 for partial oxidation.

**Method 2: IPCC Tier 2 methodology — ammonia production (input material based)**

The total fuel requirement values per unit of output in

Table 30:3 below can be used in conjunction with data on NH<sub>3</sub> production by fuel type and process type, along with either default or country specific data on the C content factor and carbon oxidation factor of the fuels.

**Table 30:3: Default total fuel requirements (fuel plus feedstock) and emission factors for Ammonia production (per Tonne NH<sub>3</sub>)**

Production Process	Total fuel requirement (GJ (NCV)/tonne NH <sub>3</sub> ) ± uncertainty (%)	Carbon content factor [CCF] <sup>1</sup> (kg/GJ)	Carbon oxidation factor [COF] <sup>1</sup> (fraction)	CO <sub>2</sub> emission factor (tonnes CO <sub>2</sub> / tonne NH <sub>3</sub> )
<b>Modern plants – Europe</b> Conventional reforming – natural gas	30.2 (± 6%)	15.3	1	1.694
Excess air reforming – natural gas	29.7 (± 6%)	15.3	1	1.666
Auto thermal reforming – natural gas	30.2 (± 6%)	15.3	1	1.694
Partial oxidation	36.0 (± 6%)	21.0	1	2.772
<b>Derived from European average values for specific energy consumption (Mix of modern and older plants)</b> Average value – natural gas	37.5 (± 7%)	15.3	1	2.104
Average value – partial oxidation	42.5 (± 7%)	21.0	1	3.273
NCV – Net Calorific Value. 1. Values from IPCC 2006, Vol. 2 Energy, Chapter.1, Tables 1.3 and 1.4 Source: Adapted from EFMA (2000, p.21); de Beer, Phylipsen and Bates (2001, p.21); for modern plants default factors can be derived using C content based on natural gas (dry basis) and partial oxidation default factors can be derived using C content based on residual fuel oil.				

**Method 3: IPCC Tier 3 methodology — ammonia production (input material based)**

Plant-level data on total fuel requirement provide the most rigorous data for calculating CO<sub>2</sub> emissions from ammonia production. It is *good practice* to obtain information on the CCF and COF from producers or use country-specific energy sector data. The CCF is



the key emission factor variable for deriving the quantity of CO<sub>2</sub> emissions. Derivation of emissions using plant-level ammonia production depends on an accurate estimate of the fuel requirement per unit of output, along with information on the other variables.

## 31. Nitric Acid Production

Nitric acid is mainly used as a raw material for nitrogenous-based fertiliser. It can however also be used in the production of explosives, metal etching and in the processing of ferrous metals.

The production of nitric acid produces N<sub>2</sub>O. Abatement of N<sub>2</sub>O can be intentional, through installation of equipment designed to destroy N<sub>2</sub>O, or unintentional in systems designed to abate other emissions such as nitrogen oxides (NO<sub>x</sub>). The specific abatement technology implemented onsite affects the abatement achieved. During quantification of the emissions from nitric acid production the abatement achieved must be taken into consideration.

### 31.1. IPCC Classification

During the production of nitric acid, emissions arise from stationary combustion of fuels, as well as process emissions. Process emissions under the IPCC are the emissions from industrial processes involving chemical transformations other than combustion. The methodology to determine the emissions associated with nitric acid production is detailed in Volume 3, Chapter 3 of the 2006 IPCC guidelines.

The table below details the relationship between direct emission sources and the IPCC classification as per the Regulations.

**Table 31:1: IPCC classification of emissions for Nitric Acid Production**

Sector	Relevant IPCC code/s	Definition	Relevant IPCC Gases	Tier	Methodology reference	Transitional arrangements
Nitric Acid Production	1A2c	Fuel combustion activities in the chemicals sector.	CO <sub>2</sub>	2 or 3	Section 12	Yes
			CH <sub>4</sub>	1, 2 or 3	Section 12	No
			N <sub>2</sub> O	1, 2 or 3	Section 12	No
	2B2	Nitric acid production process emissions.	N <sub>2</sub> O	2 or 3	Section 31	Yes

Please note that the table above details the sectors that should be covered as a minimum. If there are other emission sources under control of the data provider that still need to be reported, please report them under the relevant categories as listed in Table 5:2 of this document.

## 31.2. Methodology

### Method 1: IPCC Tier 1 methodology — nitric acid production

Method 1 for emissions released from the production of nitric acid is derived from the Tier 1 IPCC methodology. The Tier 1 method assumes there is no abatement of N<sub>2</sub>O emissions, and the highest default emission factor based on technology type shown in the 2006 IPCC Guidelines Table 3.3 should be used:

$$E_{ijk} = [EF_{ijk} \times A_{ik}] / 1000$$

Where:

$E_{ijk}$  is the emissions of nitrous oxide released during the year from the production of nitric acid at plant type ( $k$ ) measured in tonnes.

$EF_{ijk}$  is the emission factor in kilograms of nitrous oxide for each tonne of nitric acid produced during the year from plant type ( $k$ ).

$A_{ik}$  is the quantity, measured in tonnes of nitric acid produced during the year from plant type ( $k$ ).

For  $EF_{ijk}$  in subsection (1), the table below specifies the emission factor of nitrous oxide for each tonne of nitric acid produced by process plant type ( $k$ ).

A factor of 1000 to convert from kilograms to tonnes of the relevant Greenhouse gas

### Method 2: IPCC Tier 2 methodology — nitric acid production

The tier 2 method for estimating N<sub>2</sub>O emissions includes additional terms that recognise the potential future use of N<sub>2</sub>O abatement technologies. The N<sub>2</sub>O destruction factor has to be multiplied by an abatement system utilisation factor in order to account for any downtime of the emission abatement equipment (i.e., time the equipment is not operating).

$$E_{ijk} = [EF_{ijk} \times A_{ik} \times (1 - DF_j \times ASUF_j)] / 1000$$

Where:

$E_{ijk}$  is the emissions of nitrous oxide released during the year from the production of nitric acid at plant type ( $k$ ) measured in tonnes

$EF_{ijk}$  is the emission factor in kilograms of nitrous oxide for each tonne of nitric acid produced during the year from plant type ( $k$ )

$A_{ik}$  is the quantity, measured in tonnes, of nitric acid produced during the year from plant type ( $k$ )

$DF_j$  = destruction factor for abatement technology type  $j$ , fraction

$ASUF_j$  = abatement system utilization factor for abatement technology type  $j$ , fraction

For method 2, all data on nitrous oxide concentrations, volumetric flow rates and nitric acid production for each sampling period must be used to estimate the flow-weighted average emission rate of nitrous oxide for each unit of nitric acid produced from the plant

For detailed equations and further guidance please refer to volume 3, chapter 3, section 3.3 'Nitric Acid Production' in the 2006 IPCC Guidelines.

**Method 3: IPCC Tier 3 methodology - nitric acid production**

While Method 2 applies technology specific emission factors reflecting the national technology mix. Method 3 is based on real measurement data. This can be in the form of plant-level production data disaggregated by technology type and plant level emission factors obtained from direct measurement of emissions. These may be derived from irregular sampling of emissions of N<sub>2</sub>O or periodic emissions monitoring of N<sub>2</sub>O undertaken over a period(s) that reflects the usual pattern of operation of the plant.

Alternatively, the Tier 3 method uses the results of continuous emissions monitoring (CEM). Where CEM is employed, emissions can be estimated based on the sum of measured N<sub>2</sub>O emissions derived from the concentration of N<sub>2</sub>O in monitored emissions for each recorded monitoring interval. Guidance on measurement methods for N<sub>2</sub>O and other greenhouse gases are provided in Section 7.1.

**31.3. Activity Data**

For details on choice of activity data please refer to section 3.3.2.3 in Volume 3 Chapter 3 of the 2006 IPCC Guidelines.

**Table 31:2: Nitric acid production emissions data requirements**

Tier 1	Tier 2	Tier 3	Other information
i) Quantity of Nitric acid produced per annum	i) Quantity of Nitric acid produced per annum, from each plant ii) Nitric acid production process	Plant specific-emission data based on plant production data and emission factors, given there is irregular sampling and continuous monitoring of data	i) Information on implemented GHG emission abatement technology and estimates of abatement ii) Plant specific GHG emission factors, if available iii) Technology of plant (high, medium, low pressure plants, etc.) iv) Age of plant v) Information on data quality and uncertainty estimates

### 31.4. Emission Factors

For details on choice of process related emission factors please refer to section 3.3.2.2 in Volume 3 Chapter 3 of the 2006 IPCC Guidelines.

**Table 31:3: Default factors for Nitric Acid production for IPCC tier 1 and 2 methodologies (IPCC 2006)**

<b>Production Process</b>	<b>N<sub>2</sub>O Emission Factor (relating to 100 per cent pure acid)</b>
Plants with NSCR* (all processes)	2 kg N <sub>2</sub> O/tonne nitric acid ±10%
Plants with process-integrated or tail gas N <sub>2</sub> O destruction	2.5 kg N <sub>2</sub> O/tonne nitric acid ±10%
Atmospheric pressure plants (low pressure)	5 kg N <sub>2</sub> O/tonne nitric acid ±10%
Medium pressure combustion plants	7 kg N <sub>2</sub> O/tonne nitric acid ±20%
High pressure plants	9 kg N <sub>2</sub> O/tonne nitric acid ±40%

\* non-selective catalytic reduction

## 32. Carbide Production

Carbide production includes the production of silicon carbide (SiC) and calcium carbide (CaC<sub>2</sub>). The production of these carbides results in GHG emissions.

### Calcium Carbide production:

The calcium carbide production source category consists of any process that produces calcium carbide. Calcium carbide is used in the production of acetylene, in the manufacture of cyanamide and as a reductant in electric arc steel furnaces. It is made from two carbon containing raw materials: calcium carbonate (limestone) and petroleum coke.

In most calcium carbide plants CO off-gas is used as an energy source. In order to prevent double counting, emissions from the combustion of CO gas to CO<sub>2</sub> should be accounted for in the IPCC category “2B5 Carbide Production” and should not be included in the stationary combustion category

CaO (lime) might be produced in-house or at a plant other than the carbide plant. In either case, the emissions from the CaO step should be reported as emissions from lime production (see Annexure 14). Only the emissions from reaction of CaO with petroleum coke and use of the product to produce acetylene for welding applications should be reported as emissions from calcium carbide

### Silicon Carbide Production:

The silicon carbide production source category consists of any process that produces silicon carbide for abrasive purposes. Silicon carbide is produced from silica sand or quartz and petroleum coke reacting in an arc furnace. The methodology to determine the emissions associated with carbide production is detailed in Volume 3, Chapter 3 of the 2006 IPCC guidelines.

### 32.1. IPCC Classification

Table 32:1: IPCC classification of emissions for silicon carbide production

Sector	Relevant IPCC code/s	Definition	Relevant IPCC Gases	Tier	Methodology reference	Transitional arrangements
Carbide Production	1A2c	Fuel combustion activities in the chemicals sector	CO <sub>2</sub>	2 or 3	Section 12	Yes
			CH <sub>4</sub>	1, 2 or 3	Section 12	No
			N <sub>2</sub> O	1, 2 or 3	Section 12	No
	2B5	Carbide production process emissions	CO <sub>2</sub>	2 or 3	Section 32	Yes

Please note that the table above details the sectors that should be covered as a minimum. If there are other emission sources, under control of the data provider, that still need to be reported please report them under the relevant categories as listed in Table 5:2 of this document.

## **32.2. Methodology**

### **Method 1: IPCC Tier 1 methodology - carbide production**

The Tier 1 method requires data on petroleum coke used in carbide production. Emissions from carbide production can be estimated from activity data (AD) on petroleum coke consumption or carbide production, calcium carbide used in the production of acetylene used in welding applications, and default emission factors. Where AD on petroleum coke consumption are used, the carbon content factor (CCF) and carbon oxidation factor (COF) of the petroleum coke can be obtained from the 2006 IPCC Guidelines, Volume 2, Chapter 1 and the result must be multiplied by 44/12 to convert C to CO<sub>2</sub>.

### **Method 2: IPCC Tier 2 methodology – carbide production**

Activity data required for the Tier 2 method comprises plant-level data on carbide produced and the amount of CaC<sub>2</sub> used in the production of acetylene. Emission factors used in the Tier 2 method are default emission factor values except for the amount of carbon contained in the product, where plant-level data is required (see emission factor tables in section 18 below).

### **Method 3: IPCC Tier 3 methodology – carbide production**

The Tier 3 method requires plant-level activity data for all variables including the petroleum coke input, along with the carbon content factor (CCF) and carbon oxidation factor (COF) if available.

In the case of CaC<sub>2</sub>, data on the use of CaC<sub>2</sub> used to produce acetylene is required. Emission factors used in the Tier 3 method require plant-level data for all variables except for CCF and COF of the petroleum coke where country specific energy sector values may be used. Plant-level data on the amount of carbon contained in the product are also required.

Further guidance for the quantification of CO<sub>2</sub> emissions from carbide production using Tier 2 and Tier 3 methods are provided in the 2006 IPCC Guidelines, volume 3, chapter 3, section 3.6.2.1.

### 32.3. Activity Data

For further details on activity data please refer to section 3.6.2.3 of Volume 3, Chapter 3 of the 2006 IPCC Guidelines.

**Table 32.2: Carbide production emissions activity data (silicon and calcium carbide)**

Tier 1	Tier 2	Other information
i) Quantity of petroleum coke consumption or carbide production, tonnes raw material used, or tonnes carbide produced, national level	i) Quantity of petroleum coke consumption or carbide production, tonnes raw material used, or tonnes carbide produced, at plant level ii) Plant specific emission factors, if available	i) Plant specific GHG emission factors, if available ii) Information on data quality and uncertainty estimates

### 32.4. Emission Factors

For further details on emission factors please refer to section 3.6.2.2 of Volume 3, Chapter 3 of the 2006 IPCC Guidelines.

#### CO<sub>2</sub> from silicon carbide production

More carbon is needed in the silicon carbide production process than calculated from a stoichiometric reaction. The excess carbon is oxidised during the process, with little being left as ash (Raanes, 1991). Typical default values for Norwegian plants for carbon content in coke are 97 per cent and for carbon contained in product, 35 per cent. This implies a typical emission factor of 2.3 tonnes CO<sub>2</sub>/tonne petroleum coke used (IPCC 1997 in IPCC 2006, V3, Ch3, 3.44), or 2.62 tonnes CO<sub>2</sub>/tonne carbide produced.

#### CH<sub>4</sub> from silicon carbide production

Measurements at Norwegian plants suggest emission factors of 10.2 kg CH<sub>4</sub>/tonne petroleum coke or 11.6 kg CH<sub>4</sub>/tonne carbide produced (IPCC 1997 in IPCC 2006, V3, Ch3, 3.44).



Table 32:3: Default emission factors for silicon and carbide production (IPCC 2006)

Process	Emission Factor (tonnes CO <sub>2</sub> /tonne raw material used)	Emission Factor (kg CH <sub>4</sub> /tonne raw material used)	Emission Factor (tonnes CO <sub>2</sub> /tonne carbide produced)	Emission Factor (kg CH <sub>4</sub> /tonne carbide produced)
Silicon carbide production	2.30	10.2	2.62	11.6

### CO<sub>2</sub> from calcium carbide production

Emission factors may be derived from the use of raw materials (petroleum coke) and from carbide production using a mass-balance approach. Limestone used in carbide manufacture contains about 98 percent CaCO<sub>3</sub> and is accounted for elsewhere. 1 750 kg limestone (or 950 kg CaO), 640 kg of petroleum coke and 20 kg carbon electrodes are required to produce 1 tonne of carbide.

Table 32:4: Default emission factors for CO<sub>2</sub> emission from Calcium Carbide production and use (IPCC 2006)

Emission Factors for CO <sub>2</sub> Emission From Calcium Carbide Production and Use		
Process	Default Emission Factor (tonnes CO <sub>2</sub> /tonne raw material used)	Default Emission Factor (tonnes CO <sub>2</sub> /tonne carbide produced)
Petroleum coke use	1.70	1.090
Use of product	not relevant	1.100

The theoretical emission factor calculated from a stoichiometric reaction is lower for the petroleum coke step than that shown in the table. Excess carbon is oxidised in the process and the suggested emission factors were calculated from the actual use of raw materials in a Norwegian plant. The emission factor for acetylene use is calculated from the actual (not stoichiometric) carbon content of carbide.

### 33. Titanium Dioxide Production

The titanium dioxide (TiO<sub>2</sub>) production source category consists of any facility that uses the chloride process to produce titanium dioxide. TiO<sub>2</sub> is one of the most used white pigments.

#### 33.1. IPCC Classification

There are three processes that are used in the production of TiO<sub>2</sub> that lead to process greenhouse gas emissions: titanium slag production in electric furnaces, synthetic rutile production using the Becher process, and rutile TiO<sub>2</sub> production via the chloride route. The sulphate route for TiO<sub>2</sub> production does not give rise to process greenhouse gas emissions that are of significance.

Process emissions in TiO<sub>2</sub> production are produced primarily because of anode carbon oxidation in the production of titanium slag, coal oxidation in the process of producing synthetic rutile using the Becher process, and petroleum coke oxidation in the process of producing rutile TiO<sub>2</sub> via the chloride route. The methodology to determine the emissions associated with titanium dioxide production is detailed in Volume 3, Chapter 3 of the 2006 IPCC guidelines.

The relevant emission categories to be reported for titanium dioxide production facilities are presented in the table below:

**Table 33:1: IPCC classification of emissions for titanium dioxide production**

Sector	Relevant IPCC code/s	Definition	Relevant IPCC Gases	Tier	Methodology reference	Transitional arrangements
Titanium dioxide Production	1A2c	Fuel combustion activities in the chemicals sector.	CO <sub>2</sub>	2 or 3	Section 12	Yes
			CH <sub>4</sub>	1, 2 or 3	Section 12	No
			N <sub>2</sub> O	1, 2 or 3	Section 12	No
	2B6	Titanium dioxide production process emissions.	CO <sub>2</sub>	2 or 3	Section 33	Yes

To prevent double counting, the quantities of electrode carbon coal used as a reductant, and petroleum coke used in the chloride route process, for the production of TiO<sub>2</sub> must be reported as emissions under the process emissions category only.

Please note that the table above details the sectors that should be covered as a minimum. If there are other emission sources, under control of the data provider, that still need to be reported please report them under the relevant IPCC source categories guided by Section 5 of these guidelines or Annexure 1 of the NGERs.

### 33.2. Methodology

#### Method 1: IPCC Tier 1 methodology – titanium dioxide production

The Tier 1 method uses production data multiplied by a default emission factor. See section 33.4 for emission factors.

#### Method 2: IPCC Tier 2 methodology – titanium dioxide production

The Tier 2 method uses plant-level data on the quantities of reducing agent, carbon electrode consumption and carbothermal input to calculate emissions. Carbon content of the reductant and carbothermal inputs along with the proportion of carbon oxidised, are the key emission factor variables for deriving the quantity of CO<sub>2</sub> emitted. Specific equations for use of the Tier 2 method are provided in the 2006 IPCC Guidelines, Volume 3, Chapter 3, section 3.7.2.1. Where no plant specific emission factors are available refer to Table 3.9 of the 2006 IPCC Guidelines, Volume 3, Chapter 3, section 3.7.2.2.

### 33.3. Activity Data

For further details on activity data please refer to section 3.7.2.3 of Volume 3, Chapter 3 of the 2006 IPCC Guidelines.

**Table 33:2: Titanium dioxide production emissions data requirements**

Tier 1	Tier 2	Other information
i) Quantity of titanium slag, synthetic rutile or rutile produced per annum (national level)	i) Quantity of the reducing agent for electrode carbon (titanium slag), and coal (synthetic rutile) in the Becher process, and the carbothermal input (petroleum coke) for rutile TiO <sub>2</sub> from the chloride route process, at plant level ii) Carbon content factor of reducing agent or carbothermal input, kg C/GJ	i) Information on implemented GHG emission destruction technology and estimates of amount destroyed ii) Information on data quality and uncertainty estimates

### 33.4. Emission Factors

For further details on emission factors please refer to section 3.7.2.2 of Volume 3, Chapter 3 of the 2006 IPCC Guidelines. For ease of reference, the emission factors are also included in this section.

Table 33:3: Default emission factors for titanium dioxide production (IPCC 2006)

Product	Emission factor and respective uncertainty (tonnes CO <sub>2</sub> /tonne product)
Titanium slag <sup>16</sup>	Not available
Synthetic rutile <sup>17</sup>	1.43 (± 10%)
Rutile titanium dioxide (chloride route) <sup>18</sup>	1.34 (± 15%)

<sup>16</sup> A default emission factor is not available because there are two plants only, Richards Bay in South Africa, and Allard Lake in Canada, and data are confidential. It is good practice for the respective countries to include plant specific estimates of emissions in their national greenhouse gas inventories.

<sup>17</sup> Derived from data provided by Iluka Resources.

<sup>18</sup> Adapted from EIPPCB (2004a; p.99).

## 34. Soda Ash Production

Soda ash (sodium carbonate,  $\text{Na}_2\text{CO}_3$ ) is used as a raw material in many industries including glass manufacture, soap and detergents, pulp and paper production and water treatment.

$\text{CO}_2$  is emitted during the production of soda ash. The quantity of  $\text{CO}_2$  emitted during the production, is dependent on the industrial process used to manufacture soda ash. There are four manufacturing processes used commercially. Three of these processes, monohydrate, sodium sesquicarbonate (trona) and direct carbonation, are referred to as natural processes. The fourth, the Solvay process, is classified as a synthetic process. The methodology to determine the emissions associated with soda ash production is detailed in Volume 3, Chapter 3 of the 2006 IPCC guidelines.

### 34.1. IPCC Classification

The relevant emission categories to be reported for soda ash production facilities are presented in the table below:

**Table 34:1: IPCC classification of emissions for soda ash production**

Sector	Relevant IPCC code/s	Definition	Relevant IPCC Gases	Tier	Methodology reference	Transitional arrangements
Soda Ash Production	1A2c	Fuel combustion activities in the chemicals sector.	$\text{CO}_2$	2 or 3	Section 12	Yes
			$\text{CH}_4$	1, 2 or 3	Section 12	No
			$\text{N}_2\text{O}$	1, 2 or 3	Section 12	No
	2B7	Soda ash production process emissions.	$\text{CO}_2$	2 or 3	Section 34	Yes

To avoid double counting the coke used in the soda ash production process is only classified as a non-energy use of coke and reported under process emission. The coke used must not be incorporated under the stationary combustion category.

Please note that the table above details the sectors that should be covered as a minimum. If there are other emission sources under control of the data provider that still need to be reported, please report them under the relevant categories as listed in Table 5:2 of this document.

### 34.2. Methodology

The quantification of company specific emissions from the production of soda ash should be calculated following either the Tier 2 or Tier 3 method. The Tier 2 method is based on complete plant-level input or output data and plant specific emission factors. The Tier 3 method uses direct measurement of the  $\text{CO}_2$  emissions, using continuous emissions monitoring estimations.

### Natural soda ash production

To calculate emissions on a company level the Tier 2 method can be used. For this method, the activity data is the Trona consumption or natural soda ash production for each plant. In addition, a plant-specific emission factors for the Trona input or soda ash output is most appropriate for use, however for plants where plant-specific emission factors are not available, the default emission factors provided for use in the 2006 IPCC Guidelines are:

- $EF_{\text{Trona}} = 0.097$  tonnes  $\text{CO}_2$ /tonne Trona
- $EF_{\text{Soda Ash}} = 0.138$  tonnes  $\text{CO}_2$ /tonne natural soda ash produced

The specific equation to calculate emissions from natural soda ash production is provided in Equation 3.14 of the 2006 IPCC Guidelines, Volume 3, Chapter 3 and section 3.8.2.1.

The Tier 3 method uses plant-level  $\text{CO}_2$  emissions data obtained from direct measurement.

### Solvay soda ash production

Carbon dioxide is produced during the Solvay process, however,  $\text{CO}_2$  generated is captured, compressed and directed to Solvay precipitating towers. Although  $\text{CO}_2$  is generated as a by-product, the  $\text{CO}_2$  is recovered and recycled for use in the carbonation stage and in theory the process is neutral.

However, in practice, more  $\text{CO}_2$  is produced than is stoichiometrically required and thus some  $\text{CO}_2$  is emitted to the atmosphere. The estimation of the  $\text{CO}_2$  emissions from a standalone soda ash plant should be estimated based on an overall balance of  $\text{CO}_2$  around the whole chemical process. To calculate the emissions related to a company, a simplified version of the balance may be used assuming that  $\text{CO}_2$  emissions from the process plant result from the stoichiometric oxidation of the coke carbon.

Emissions generated in the process of soda ash production are reported under the IPCC category "2B7 Soda Ash Production" and not under the energy sector. In order to avoid double counting coke used in the soda ash production process is only classified as a non-energy use of coke and is not incorporated under the stationary combustion energy sector.

### 34.3. Activity Data

For further details on activity data please refer to section 3.8.2.1 of Volume 3, Chapter 3 of the 2006 IPCC Guidelines.

**Table 34:2: Soda ash production emissions data requirements (natural soda ash)**

<b>Tier 1</b>	<b>Tier 2</b>	<b>Other information</b>
i) Quantity of Trona used or soda ash produced per annum, at national level	i) Quantity of Trona used or soda ash produced per annum, at plant level ii) plant-specific emission factors for the Trona input or soda ash output	i) Plant-specific emission factors for the Trona input or soda ash output, tonnes CO <sub>2</sub> /tonne of Trona or tonnes CO <sub>2</sub> /tonne natural soda ash produced ii) Information on data quality and uncertainty estimates

### 34.4. Emission Factors

For further details on emission factors please refer to section 3.8.2.1 of Volume 3, Chapter 3 of the 2006 IPCC Guidelines and the methodology section above.

## 35. Petrochemical and Carbon Black Production

The petrochemical industry uses fossil fuels or petroleum refinery products as feedstock. Guidance on estimating emissions is given for companies who produce methanol, ethylene, ethylene dichloride and vinyl chloride monomer, ethylene oxide, and acrylonitrile and carbon black. In addition guidance is provided for the quantification of emissions from the production of carbon black.

### 35.1. IPCC Classification

Companies with petrochemical or carbon black production facilities must report direct emissions from their petrochemical or carbon black processing plant in the IPCC category 2B8 Petrochemical and Carbon Black Production.

In the petrochemical or carbon black process some feedstocks produce intermediary fuels. The combustion emissions from these intermediary fuels obtained from the feedstocks should be allocated to the source category in the 2B8 Petrochemical and Carbon Black Production. However, when the intermediary fuels are not used in the process but are transferred for combustion elsewhere the emissions should be reported in the appropriate energy source category, such as stationary combustion (1A2c).

In addition to emissions from the processing plant reported under category 2B8 of the IPCC, each facility must report GHG emissions for other emission sources in their company as well, for which categories and calculation methods are provided. The methodology to determine the emissions associated with petrochemical and carbon black production is detailed in Volume 3, Chapter 3 of the 2006 IPCC guidelines.

The minimum relevant emission categories to be reported for petrochemical and carbon black production facilities are presented in the table below:

Table 35:1: IPCC classification of emissions from petrochemical and carbon black production.

Sector	Relevant IPCC code/s	Definition	Relevant IPCC Gases	Tier	Methodology reference	Transitional arrangements
Petro-chemical and Carbon Black Production	1A2c	Fuel combustion activities in the chemicals sector	CO <sub>2</sub>	2 or 3	Section 12	Yes
			CH <sub>4</sub>	1, 2 or 3	Section 12	No
			N <sub>2</sub> O	1, 2 or 3	Section 12	No
	2B8a-f	Petrochemical and carbon black production process emissions	CO <sub>2</sub>	2 or 3	Section 35	Yes
			CH <sub>4</sub>	1, 2 or 3	Section 35	No



	2B8g	Hydrogen production	CO <sub>2</sub>	2 or 3	Section 36	Yes
--	------	---------------------	-----------------	--------	------------	-----

Some feedstocks used in the petrochemical production process produce intermediary fuels which are used within the processing plant. The emissions from the combustion of these intermediary fuels should be reported under 2B8, Petrochemical and Carbon Black Production.

Please note that the table above details the sectors that should be covered as a minimum. If there are other emission sources, under control of the data provider, that still need to be reported please report them under the relevant IPCC source categories as listed in Section 5 of this document.

### 35.2. Methodology

The production of both petrochemical and carbon black produce GHG emissions. The emissions which arise vary both with the production process used and feedstock used.

#### Method 1: IPCC Tier 1 methodology - carbon black production

Tier 1 method calculates emissions from petrochemical processes based on the activity data for production of each petrochemical and the process-specific emission factor for each petrochemical, as shown below:

$$ECO_{2i} = PP_i \times EFi \times GAF / 1000$$

Where:

$ECO_{2i}$  = CO<sub>2</sub> emissions from production of petrochemical  $i$ , Gg

$PP_i$  = annual production of petrochemical  $i$ , tonnes

$EF_i$  = CO<sub>2</sub> emission factor for petrochemical  $i$ , tonnes CO<sub>2</sub>/tonne product produced (IPCC 2006 V3, Ch3, Tables 3.10-3.24)

$GAF$  = Geographic adjustment factor (for Tier 1 CO<sub>2</sub> emission factors for ethylene production, see IPCC 2006 V3, Ch3, Table 3.15), per cent

A factor of 1000 to convert from tonnes to Gigagrams of the relevant Greenhouse gas.

#### Method 2: IPCC Tier 2 methodology - carbon black production

The Tier 2 methodology is a mass balance approach that is applicable to estimating CO<sub>2</sub> emissions. Should carbon dioxide (CO<sub>2</sub>) capture technology be installed and used at a plant, these emissions should be deducted from calculated emissions when using a Tier 2 or Tier 3 approach.

The Tier 2 methodology is a mass balance approach which requires the quantity of feedstock consumption and primary and secondary product production and disposition. To calculate CO<sub>2</sub> emissions using this approach, guidance is given in section 3.9.2.1 using Equation 3.17 of the 2006 IPCC Guidelines, Volume 3, Chapter 3.

**Method 3: IPCC Tier 3 methodology - carbon black production**

The Tier 3 approach is the most accurate approach to use and requires the use of plant specific data and/or plant specific measurements. To calculate CO<sub>2</sub> emissions using this approach, guidance is given in section 3.9.2.1 using equations 3.20–3.22 of the 2006 IPCC Guidelines, Volume 3, Chapter 3.

**35.3. Activity Data**

Guidance on the selection of activity data is provided according to the petrochemical product produced. Please refer to section 3.9.2.3 of Volume 3, Chapter 3 of the 2006 IPCC Guidelines.

**Table 35:2: Petrochemical (methanol, ethylene, ethylene dichloride and chloride monomer, ethylene oxide, acrylonitrile) and Carbon black production emissions activity data**

Tier 1	Tier 2	Other information
i) Quantity of petrochemicals and carbon black produced per annum, by type or annual consumption of feedstock consumed for production of petrochemical or carbon black, by type	i) Annual consumption of feedstock for production of petrochemical, by type ii) Annual production of primary petrochemical product, by type iii) Annual amount of secondary product produced, by type (for ethylene production and acrylonitrile production)	i) Fuel or process by-products combusted to provide heat or thermal energy to the production process for petrochemicals ii) Amount of gas, by type, flared during production of petrochemicals iii) Net calorific value of flared gas iv) CO <sub>2</sub> emission factor of flared gas v) Information and estimates of methane venting and/or flaring from the production of petrochemicals vi) Process configuration for the petrochemical or carbon black production (e.g. conventional steam reforming, with primary reformer for methanol, direct chlorination process for ethylene dichloride, and thermal black process for carbon black) vii) Information on data quality and uncertainty estimates.

### 35.4. Emission Factors

Guidance on the selection of emissions factors are provided depending on the petrochemical product produced. For fuel specific emission factors when using Tier 3 for the quantification of CO<sub>2</sub> emissions please refer to table 1.4 of Volume 2, Chapter 1 of the 2006 IPCC Guidelines. Also follow section 32 for guidance on direct measurements of greenhouse gases. For carbon black production, emissions factors are listed in Table 35:3.3 by process type.

**Table 35:3: Default emission factors for Carbon Black production (IPCC 2006)**

Process Configuration	tonnes CO <sub>2</sub> /tonne carbon black produced		
	Primary Feedstock	Secondary Feedstock	Total Feedstock
Furnace Black Process (default process)	1.96	0.66	2.62
Thermal Black Process	4.59	0.66	5.25
Acetylene Black Process	0.12	0.66	0.78
<b>Process Configuration</b>			
<b>kilogram CH<sub>4</sub>/tonne carbon black produced (Carbon Black Process Tail Gas)</b>			
No Thermal Treatment	28.7		
Thermal Treatment (default process)	0.06		

### 36. Hydrogen production

Hydrogen can be produced through a wide range of chemical, thermochemical and biological processes (see Table 36:1 below). The predominant hydrogen production technologies, accounting for more than 95 percent of global hydrogen production, are steam reforming (Figure 36:1 below) and gasification of fossil fuels. This section is applicable to hydrogen that is produced through the steam reforming process. The hydrogen is produced for consumption in hydro-processing units within petrochemical refineries.

**Table 36:1: Current hydrogen production methods - status of development and allocation of emission factors**

Category	Technology	Feedstock	Status of Development <sup>1</sup>	Sector	Allocation Principle	Greenhouse Gases
Pure main product hydrogen	Steam Reforming	Fossil	Major	Hydrogen Production <sup>2</sup>	Fossil process emissions	CO <sub>2</sub> , CH <sub>4</sub> <sup>3</sup>
	Gasification	Fossil	Major	Hydrogen Production <sup>2</sup>	Fossil process emissions	CO <sub>2</sub>
Bi-product or intermediate product hydrogen <sup>2</sup>	Refining of crude petroleum	All	Major	Energy (fugitive)	Hydrogen produced as by-product or intermediate product	The emissions from the manufacturing of hydrogen should be allocated to the Hydrogen production sector, while the emissions from production of the aromatic substances used as “empty carriers” should be allocated to the Petrochemical and carbon black sector. <sup>4</sup>
	Ammonia production	All	Major	Ammonia production	Hydrogen produced as by-product or intermediate product	Emission to be allocated to Ammonia production <sup>4</sup>
	Methanol production	All	Major	Petrochemical and carbon black	Hydrogen produced as by-product or intermediate product	The process at the downstream facility to release hydrogen from the methanol generates process emissions of CO <sub>2</sub> . These emissions should be reported in the Hydrogen production sector. <sup>4</sup>

<p>Notes:</p> <p><sup>1</sup> Status of development refers to the current situation in a global scale. Major, moderate and minor reflect the amount of industrial hydrogen production. Experimental means that the hydrogen is not yet produced in an industrial scale.</p> <p><sup>2</sup> Where hydrogen is produced as a by-product or intermediate product, the emissions are typically already accounted for in the emission estimates for the respective sectors derived using methodological guidance in Volume 3 Energy or Volume 4 IPPU. Emissions from production of hydrogen as part of mixtures with other gases, e.g., syngas, are not covered by this section. See Box 3.15 for the definition of main product, by-product and intermediate product and Box 3.16 about double counting.</p> <p><sup>3</sup> Lipman, T. (2011) An Overview of Hydrogen Production and Storage Systems with Renewable Hydrogen Case Studies</p> <p><sup>4</sup> 2019 Refinement to the 2006 IPCC Guidelines for National Greenhouse Gas Inventories, Volume 3, Page 3.39</p>	
--	--

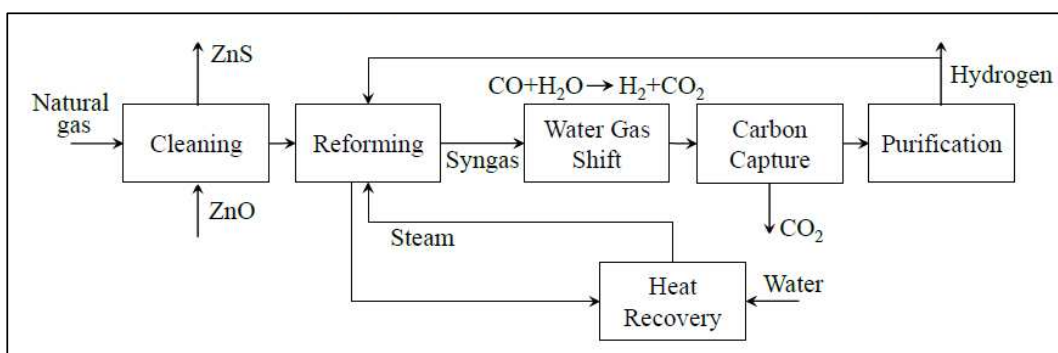

Figure 36.1: Steam reforming process flow

**36.1. IPCC Classification**

The table below details the relevant IPCC source code to be reported for hydrogen production through steam reforming. Note that this is a new, SA specific, code that is not contained in the 2006 IPCC Guidelines.

Table 36.2: IPCC classification of emissions for hydrogen production

Sector	Relevant IPCC code/s	Definition	Relevant IPCC Gases	Tier	Methodology reference	Transitional arrangements
Hydrogen Production	1A1b	All combustion activities supporting the refining of petroleum products including on-site combustion for the generation of electricity and heat for own use.	CO <sub>2</sub>	2 or 3	Section 12	Yes
			CH <sub>4</sub>	1, 2 or 3	Section 12	No
			N <sub>2</sub> O	1, 2 or 3	Section 12	No
	2B8g	Hydrogen production through the steam reforming process.	CO <sub>2</sub>	2 or 3	Section 36	Yes

### 36.2. Methodology

The choice of method will depend on the availability of activity data as per the IPCC Refinements. If all relevant activity data are available, it is good practice to choose the method having the lowest overall uncertainty. CO<sub>2</sub> released from hydrogen production may be recovered, either for capture and storage or for use in other downstream manufacturing industries.

In all emission estimation methods, it is good practice to subtract recovered CO<sub>2</sub> from the estimated emissions in the hydrogen production sector and to include the emissions in the respective downstream IPPU sector(s). If the recovered CO<sub>2</sub> is sent to permanent storage, it is good practice to subtract the recovered CO<sub>2</sub> from the hydrogen production sector.

The estimation methods below are presented using energy units (GJ) for feedstock activity data, and mass units (tonne) for the hydrogen production data. Where these parameters are reported in different units at the national or facility level (e.g. volume, mass) then unit conversions consistent with national or facility data or IPCC defaults may be applied.

#### Method One: IPCC Refinements Tier 1 Method

The Tier 1 method uses national or regional level activity data together with default factors and data on recovered CO<sub>2</sub> to derive emissions. The activity data are consumption of feedstock (Tier 1c) or production of hydrogen (Tier 1b and 1a). In the Tier 1c and 1b methods the activity data are split by type of feedstock, and feedstock specific factors provided below should be used.

Tier 1C – CO<sub>2</sub> emission from hydrogen production

$$E_{CO_2} = \sum_j (FC_j \times CCF_j \times 44/12) - R_{CO_2}$$

Tier 1B - CO<sub>2</sub> emission from hydrogen production

$$E_{CO_2} = \sum_j (HP_j \times FRF_j \times CCF_j \times 44/12) - R_{CO_2}$$

Tier 1A - CO<sub>2</sub> emission from hydrogen production

$$E_{CO_2} = HP \times FRF \times CCF \times 44/12 - R_{CO_2}$$

Where:

$E_{CO_2}$  = emissions of CO<sub>2</sub>, tonne

FC = feedstock consumption in production of pure hydrogen as main product, GJ

HP = pure hydrogen produced as main product

FRF = feedstock requirement per unit of output, GJ feedstock/ tonne hydrogen produced

CCF = carbon content factors, tonne C/GJ feedstock

j (subscript) = feedstock j

R<sub>CO2</sub> = CO<sub>2</sub> recovered, tonne

### Method Two: IPCC Refinements Tier 2 Method

The Tier 2 methods use national or regional level activity data together with country-specific factors and data on recovered CO<sub>2</sub> to derive emissions and should be used when hydrogen production is a key category and plant-specific activity data are not available. The activity data used in the Tier 2 method must be split by type of feedstock.

Tier 2C - CO<sub>2</sub> emission from hydrogen production

$$E_{CO_2} = \sum_j (FC_j \times CCF_j \times 44/12) - R_{CO_2}$$

Tier 2B - CO<sub>2</sub> emission from hydrogen production

$$E_{CO_2} = \sum_j (HP_j \times FRF_j \times CCF_j \times 44/12) - R_{CO_2}$$

Where:

E<sub>CO2</sub> = emissions of CO<sub>2</sub>, tonne

FC = feedstock consumption in production of pure hydrogen as main product, GJ

HP = pure hydrogen produced as main product

FRF = feedstock requirement per unit of output, GJ feedstock/ tonne hydrogen produced

CCF = carbon content factors, tonne C/GJ feedstock

j (subscript) = feedstock j

### Method three: IPCC Refinements Tier 3 Method

The Tier 3 methods use process- and plant-level activity data and factors together with data on recovered CO<sub>2</sub> and stored amounts of solid carbon to derive emissions.

Tier 3C - CO<sub>2</sub> emission from hydrogen production

$$E_{CO_2} = \sum_{j,n} (FC_{j,n} \times CCF_{j,n} \times 44/12) - (R_{CO_2} + S_c \times 44/12)$$

Tier 3B - CO<sub>2</sub> emission from hydrogen production

$$E_{CO_2} = \sum_{i,j,n} (FC_{i,j,n} \times FRF_{i,j,n} \times CCF_{i,j,n} \times 44/12) - (R_{CO_2} + S_c \times 44/12)$$

Where:

$E_{CO_2}$  = emissions of CO<sub>2</sub>, tonne

FC = feedstock consumption in production of pure hydrogen as main product, GJ

HP = pure hydrogen produced as main product

FRF = feedstock requirement per unit of output, GJ feedstock/ tonne hydrogen produced

CCF = carbon content factors, tonne C/GJ feedstock

j (subscript) = feedstock j

$S_c$  = stored solid carbon, tonne

**Method three: Tier 3 method (Alternative)**

*Hydrogen Plant CO<sub>2</sub> Production Rate*

The Hydrogen Plant uses the steam-methane reforming process to produce H<sub>2</sub> for consumption in the hydro-processing units. CO<sub>2</sub> is a product of the reactions to convert the hydrocarbons in the feed to H<sub>2</sub>. As example, the reaction of ethane is simplistically shown below.

**Equation 1**

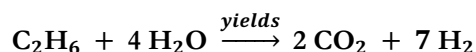

The feed to a Hydrogen Plant is normally only light alkanes (methane, ethane, propane and butane), which is the case for the existing refinery Hydrogen Plant. Alkanes have the generic formula, C<sub>n</sub>H<sub>(2n+2)</sub>. The reactions taking place in the Hydrogen Plant can then be written in the following general form:

**Equation 2**

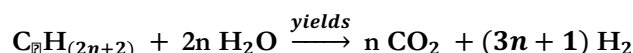

By writing the equation in the general form, it becomes evident that any of the relationships between feed and products can be determined if the value of n (the number of carbon atoms) in the feed is known.

A further point to note is that if n = 0, the feed is 100% H<sub>2</sub>. This means that the general form of the equation holds true for any mixture of hydrogen and hydrocarbons in the feed to the Hydrogen Plant by using an appropriate value for n.

The molecular weight of alkanes fed to the Hydrogen Plant can be calculated from:

**Equation 3**

$$MW \text{ of } C_nH_{(2n+2)} = n \times 12 + (2n+2) \times 1$$



where 12 is the molecular weight of the carbon atom and 1 is the molecular weight of the hydrogen atom. The equation can be simplified to:

**Equation 4**

$$\text{MW} = 14 \times n + 2$$

From this, the equivalent carbon number for any mixture of hydrogen and alkanes fed to the Hydrogen Plant can therefore be calculated from:

**Equation 5**

$$n = \frac{(\text{MW} - 2)}{14}$$

As examples:

If the feed is pure methane, the MW is 16, which results in  $n = 1$ . If the feed is pure ethane, the MW is 30, which results in  $n = 2$ . If we plug  $n = 2$  in the general form of the equation, we find exactly the same results as the equation shown above for ethane.

It was stated above that the reaction equation shown is a simplistic representation. In reality, the process chemistry is such that some residual methane remains in the product from the reforming furnace. Furthermore, the residual CO and CO<sub>2</sub> remaining in the product stream after the shift reactors and MEA absorption is converted to methane in the methanator reactor. The reactions taking place in the methanator are:

**Equation 6**

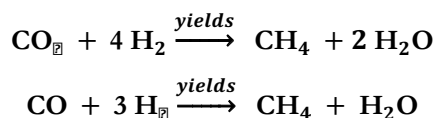

Therefore not all the hydrocarbons in the feed are converted to H<sub>2</sub> and CO<sub>2</sub>. To calculate the CO<sub>2</sub> production capacity this effect must be accounted for. The overall reaction equation in general form should thus be written as:

**Equation 7**

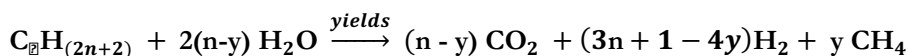

It is usual practice to have an analyser on the H<sub>2</sub> product stream that measures the concentration of CH<sub>4</sub> in the product (commonly known as the methane slip). The measurement is reported as volume% of CH<sub>4</sub>. This measurement can be used to determine the value of  $y$  in the above equation:

**Equation 8**

$$\text{Vol \% CH}_4 = \frac{\text{Amount of CH}_4}{\text{Amount of CH}_4 + \text{Amount of H}_2}$$

Setting the volume% to CH<sub>4</sub> as  $x$  and using the overall reaction molecular balance shown above, the methane slip is given by:

**Equation 9**

$$x = \frac{y}{(3n + 1 - 4y) + y} = \frac{y}{(3n + 1) - 3y}$$

Through algebraic re-arrangement, the equation can be re-written to determine y.

**Equation 10**

$$y = \frac{(3n + 1)}{\left(\frac{1}{x} + 3\right)}$$

The CO<sub>2</sub> production rate from the Hydrogen Plant can thus be calculated from the above equations 5, 7 and 10 by using only the feed flow measurement, the feed molecular weight measurement and the methane slip measurement in the product. The equations developed above are most useful to predict the theoretical CO<sub>2</sub> production rate when the H<sub>2</sub> product flow rate is not available, but the required H<sub>2</sub> production rate and feed properties are known.

If the H<sub>2</sub> product flow rate is known, the calculation of the effect of methane slip can be simplified by calculating the volume flow rate of CH<sub>4</sub> at normal conditions in the product from the measured CH<sub>4</sub> content. The CO<sub>2</sub> production rate can be calculated from the simpler equation 2 and subtracting the volume flow rate of CH<sub>4</sub> at normal conditions from the volume flow rate of CO<sub>2</sub> at normal conditions obtained from equation 2.

Example calculations for determination of the CO<sub>2</sub> production rate are given in section 43.3 below.

**Example Calculations of CO<sub>2</sub> Production Rate**

Assume the following feed is available.

	vol%	MW
H2	60%	2
C1	0%	16
C2	40%	30
C3	0%	44
Total	100%	13.2

From equation 5, the equivalent carbon number is

$$n = \frac{(13.2 - 2)}{14} = 0.8$$

Assume the required Hydrogen Plant product rate is 32000 Nm<sup>3</sup>/h. Furthermore, assume that the methane slip is 3%.

From equation 10, the amount of methane per amount of feed produced, y, is

$$y = \frac{(3 \times 0.8 + 1)}{\left(\frac{1}{0.03} + 3\right)} = \frac{3.4}{36.33} = 0.094$$

The H<sub>2</sub> produced is 31040 (32000 \* 0.97) nm<sup>3</sup>/h. From equation 7, the feed required to produce this amount of H<sub>2</sub> is

$$\text{Feed} = \frac{31040}{(3 \times 0.8 + 1 - 4 \times 0.094)} = \frac{31040}{3.024} = 10265 \text{ Nm}^3/\text{h}$$

Also from equation 7, the CO<sub>2</sub> production rate is

$$\text{CO}_2 = (0.8 - 0.094) \times 10265 = 7247 \text{ Nm}^3/\text{h}$$

### 36.3. Activity Data

Guidance on the selection of activity data is provided according to the tier used. Please refer to section 3.11.2.3 of Volume 3, Chapter 3 of the 2019 IPCC Refinements.

Table 36:3: Hydrogen production activity data requirements

Tier 1	Tier 2	Tier 3
i) In the Tier 1c method, feedstock consumption data by type of feedstock ii) In the Tier 1b method, hydrogen production data by type of feedstock iii) In the Tier 1a method, total hydrogen production	i) Feedstock consumption data by type of feedstock ii) Hydrogen production data by type of feedstock iii) Total hydrogen production	i) Plant-level activity data by production method ii) Type of feedstock iii) Recovered CO <sub>2</sub>

### 36.4. Emission Factors

For details on choice of emission factors please refer to section 3.11.2.2 in Volume 3, Chapter 4 of the 2019 IPCC Refinements. Table 36:4 provided the default carbon content factors as per the 2019 IPCC Refinements.

Table 36:4: Default carbon content factors for Hydrogen Production (2019 IPCC Refinements)

Production Process	Feedstock Requirement Factor (FRF) (GJ feedstock/tonne H <sub>2</sub> ) ± Uncertainty <sup>1</sup>	Carbon Content Factor (CCF) <sup>2</sup> (tonne C / GJ feedstock)		
		Default	Lower	Upper
<b>Steam Reforming</b>				
Natural Gas Reforming	165 (± 10%)	0.0153	0.0148	0.0159
Liquified petroleum gas reforming	165 (± 15%)	0.0172	0.0168	0.0179
Naphtha Reforming	165 (± 15%)	0.0200	0.0189	0.0208
Methanol Reforming	165 (± 20%)	0.0188	0.0186	0.0190
Biosteam reforming, other liquid (bioethanol)	175 (± 20%)	0.0217	0.0183	0.0260

Gasification				
Coal gasification (coking coal) <sup>3</sup>	215 (± 20%)	0.0258	0.0238	0.0276
Plastic <sup>4</sup> gasification	185 (± 10%)	0.0200	0.0160	0.0240
Mixed waste gasification (non-biomass fraction)	275 (± 15%)	0.0250	0.0200	0.0330
Wood waste gasification	260 (± 10%)	0.0305	0.0259	0.0360
Wood sludge gasification	195 (± 15%)	0.0305	0.0259	0.0360
Black liquor gasification	150 (± 10%)	0.0260	0.0220	0.0300
General				
Default	175 (± 30%) <sup>5</sup>	0.0183 <sup>6</sup>	0.0148 <sup>6</sup>	0.0276 <sup>6</sup>
<b>Notes:</b>				
<p><sup>1</sup> When uncertainty range is not given in the referenced literature for a given factor, a default uncertainty of ±20% is chosen. When only one literature value is found, a default minimum uncertainty of ±15% is chosen.</p> <p><sup>2</sup> The factors are also found in Table 1.3 Default values of carbon content in Volume 2.</p> <p><sup>3</sup> Hydrogen production from coal is currently dominated by use of coking coal as feedstock. Where coal of other quality is used, then it is good practice in the Tier 1 method to: (i) apply the FRF for coking coal with an uncertainty range of ±30% when the Tier 1b method is used, and (ii) apply a default CCF that reflects the specific coal type (e.g. lignite, sub-bituminous, other bituminous) as presented in Table 1.3 of Volume 2.</p> <p><sup>4</sup> Mixed plastic. For CCF the value for "other petroleum products" in Vol.2 Ch. 1 Table 1.3 is used. NCV = 32.0 MJ/kg.</p> <p><sup>5</sup> Estimated by weighted average of natural gas (49%), LPG/naphtha (29%) and coal (18%), current production methods, based on global production statistics (remaining 4% is mainly produced by electrolysis of water). Uncertainty set to cover the ranges of these three feedstock types, which are by far the most common at present.</p> <p><sup>6</sup> Estimated by weighted average of natural gas (49%), LPG/naphtha (29%) and coal (18%), current production methods, based on global production statistics (remaining 4% is mainly produced by electrolysis of water). Lower uncertainty range is from steam reforming of natural gas, upper uncertainty range is from gasification of coal.</p> <p>Source:                      Amgad et al., 2013; API, 2009; Cormos, 2011; DOE, 2017; Edwards et al., 2014; Geissler, et al., 2001; Iwasaki, 2003; JARI, 2011; Schiebahn et al., 2015; Sørensen, 2011; Themelis et al., 2011; The Pacific Northwest National Laboratory, 2017; US Department of Energy, 2017; Wallman et al., 1998.</p>				

## 37. Iron and Steel Production

A reporting company in the iron and steel sector might have a wide range of emission categories based on their inventory boundaries. In cases where a tier 2/3 method is used to quantify process CO<sub>2</sub> emissions, then CH<sub>4</sub> emissions should not be estimated separately from the carbon balance method used. The tier 2 methodology assumes an oxidation factor of 1 for all carbon containing process materials that are oxidised to form CO<sub>2</sub>. Emissions of CO<sub>2</sub>, CH<sub>4</sub> and N<sub>2</sub>O shall be reported for combustion related emissions. These emission categories are not all unique to the iron and steel industry and an iron and steel company would estimate emissions from them using the IPCC specific categories of emissions. The iron and steel industry does have some specific issues and categories of emissions that are covered in this guideline and in the 2006 IPCC Guidelines Volume 3 Chapter 4.

### 37.1. IPCC Classification

The table below details the relationship between direct CO<sub>2</sub> emission sources and the corresponding IPCC source categories for reporting under the National GHG Reporting regulations.

Table 37:1 IPCC Classification of Iron and Steel Production

Sector	Relevant IPCC code/s	Definition	Relevant IPCC Gases	Tier	Methodology reference	Transitional arrangements
Iron and Steel Production	1A2a	Fuel combustion activities in the iron and steel sector.	CO <sub>2</sub>	2 or 3	Section 12	Yes
			CH <sub>4</sub>	1, 2 or 3	Section 12	No
			N <sub>2</sub> O	1, 2 or 3	Section 12	No
	1A1ci	Emissions arising from fuel combustion for the production of coke, brown coal briquettes and patent fuel.	CO <sub>2</sub>	2 or 3	Section 12, 37	Yes
			CH <sub>4</sub>	1, 2 or 3	Section 12, 37	No
			N <sub>2</sub> O	1, 2 or 3	Section 12, 37	No
	2C1	Iron and Steel production process emissions.	CO <sub>2</sub>	2 or 3	Section 37	Yes
			<sup>19</sup> CH <sub>4</sub>	1, 2 or 3	Section 37	No
	1B1c	Fugitive emissions from coke production	<sup>20</sup> CO <sub>2</sub>	2 or 3	Section 37	Yes
CH <sub>4</sub>			1, 2 or 3	Section 37	No	

<sup>19</sup> To be considered only for Sinter production, and DRI production; (note: There is no methane factor provided for Pig Iron Production in IPCC) – there is one for coke-production.

<sup>20</sup> If it is not possible to separate CO<sub>2</sub> emissions from coke production from other process emissions then CO<sub>2</sub> emissions from coke production should be reported under 2C1.

Please note that the table above details the sectors that should be covered as a minimum. If there are other emission sources, under control of the data provider, that still need to be reported please report them under the relevant categories as listed in Table 5:2 of this document.

The schematic below explains the emissions process flow involved with Iron and Steel Production with IPCC reporting codes.

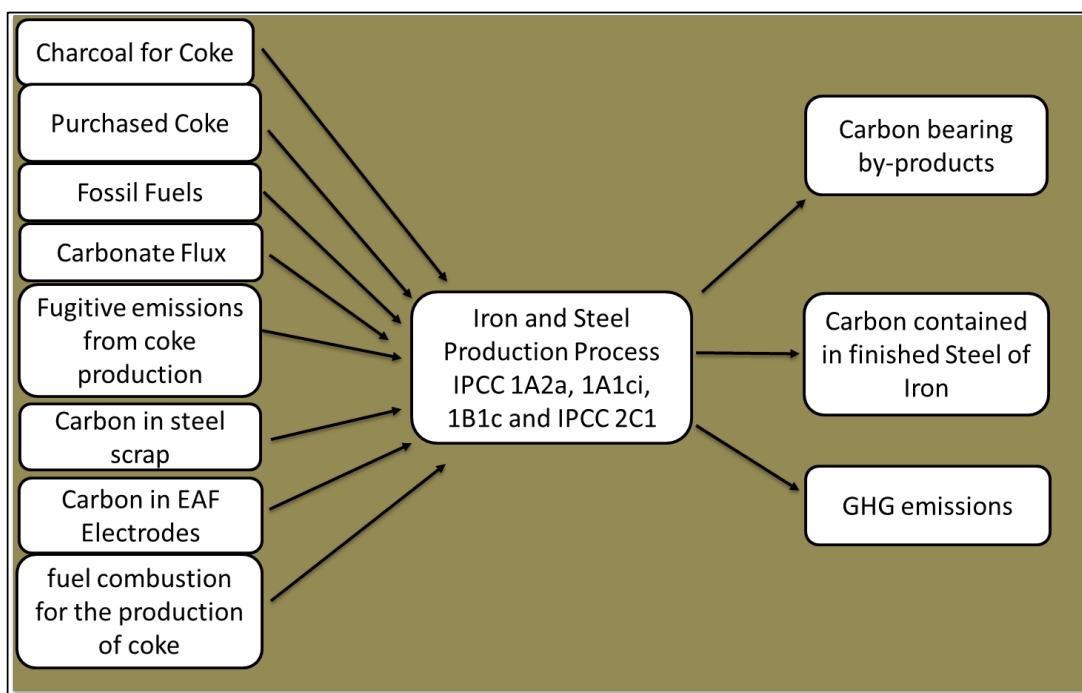

Figure 37:1: Process emissions flow for iron and steel (Including IPCC codes 1A2a, 2C1, 1A1ci and 1B1c)

Note: Where input materials are biomass based (non-fossil), then emissions only need to be reported as a memo-item.

### 37.2. Methodology

For detailed equations please refer to section 4.2 of Volume 3 Chapter 4 of the 2006 IPCC guidelines.

Technology and process conditions can differ substantially and therefore the reporting company can calculate direct GHG emissions from company-specific activity data for individual reducing agents, exhaust gases, and other process materials and products. **The estimation of emissions covers both primary and secondary processes.** As per the 2006 IPCC Guidelines, the majority of secondary production takes place using electric arc furnaces, which needs to be reported under this category

### Method 1: IPCC Tier 1 methodology – Iron and Steel production

Using the Tier 1 method in estimating iron and steel production emissions requires production data and data on default emission factors. It should be noted that the rate of emissions depends on the method of steel production, and thus where data are available emissions should be calculated based on the types of steelmaking processes and the emissions for each process should then be summed up to get total of process emissions.

- Iron and steel;  $ECO_2$ , 
$$= [BOF \cdot EF_{BOF} + EAF \cdot EF_{EAF} + OHF \cdot EF_{OHF}]$$
- Pig iron:  $ECO_2$ , 
$$= [IP \cdot EF_{IP}]$$
- Direct Reduced Iron:  $ECO_2$ , 
$$= [DRI \cdot EF_{DRI}]$$
- Sinter Production:  $ECO_2$ , 
$$= [SI \cdot EF_{SI}]$$
- Pellet Production:  $ECO_2$ , 
$$= [P \cdot EF_P]$$

Where:

- $ECO_2$  = total process emissions of  $CO_2$ , tonnes
- BOF = quantity of Basic Oxygen Furnaces (BOF), crude steel produced, tonnes
- EAF = quantity of Electric Arc Furnaces (EAF), crude steel produced, tonnes
- OHF = quantity of Open-Hearth Furnaces (OHF), crude steel produced, tonnes
- IP = quantity of pig iron production not converted to steel and that leaves reporting boundary, tonnes
- DRI = quantity of Direct Reduced Iron produced (coal or gas based) , tonnes
- SI = quantity of sinter produced, tonnes
- P = quantity of pellet produced, tonnes
- $EF_x$  = emission factor, tonnes  $CO_2$ /tonne  $x$  produced.

A factor of 1000 to convert from tonnes to Gigagrams of the relevant Greenhouse gas.

Where a Corex, Midrex, Conarc process combination is used, the following applies:

- Corex production is equivalent to pig iron production (IP) not converted to steel and that leaves reporting boundary, tonnes
- Midrex production is equivalent to Direct Reduced Iron production (DRI), tonnes
- Conarc production is equivalent to BOF crude steel production (BOF), tonnes
  - o Note: When the Conarc process is utilized in isolation with only scrap being melted, then such production is equivalent to EAF crude steel production, tonnes.

As per Volume 3, Chapter 4 of 2006 IPCC guidelines, all emissions from Iron and Steel processes are to be considered as process emissions in cases where a tier 2/3 method is used. (Section 33.3 deals more specifically with coke making emissions which need to be reported under the energy sector if a tier 1 approach is followed.)

Default emission factors can be obtained from Table 4.1 of the 2006 IPCC Guidelines (V3, Ch4, 4.25) and in Annexure C of this document.

### Method 2: IPCC Tier 2 methodology – Iron and Steel production

Method 2 sets out the estimation of emissions from a facility producing both a metal and coke. It specifies that emissions should be estimated using a carbon mass balance approach for the facility as a whole and emissions are to be reported as process (IPPU) emissions. Method 2 utilises carbon content factors listed in Table 37.3. These carbon content factors are derived directly from the carbon dioxide emission factors listed in Volume 2, Chapter 1, Table 1.3 of the 2006 IPCC Guidelines.

The carbon mass balance approach requires fuels to be estimated based on quantities of fuels delivered rather than consumed. Stock figures should be used to convert “delivered” figures to “consumption” figures as explained further in the formulas provided.

Method 2, based on a carbon mass balance approach is as follows:

- Step 1* Calculate the carbon content in fuel types (*j*) or carbonaceous input material delivered for the activity during the year measured in tonnes of carbon as follows:

$$\sum_i CCF_i \times Q_i$$

where:

$\sum_i$  means sum the carbon content values obtained for all fuel types (*j*) or carbonaceous input material.

$CCF_i$  is the carbon content factor mentioned in table 33.3 measured in kilogram of carbon per kilogram for each appropriate unit of fuel type (*j*) or carbonaceous input material consumed during the year from the operation of the activity.

$Q_i$  is the quantity of fuel type (*j*) or carbonaceous input material delivered for the activity during the year measured in tonnes.

- Step 2* Calculate the carbon content in products (*p*) leaving the activity during the year measured in tonnes of carbon as follows:

$$\sum_p CCF_p \times A_p$$

where:

$\sum_p$  means sum the carbon content values obtained for all product types (*p*).

$CCF_p$  is the carbon content factor measured in tonnes of carbon for each tonne of product type (*p*) produced during the year.

$A_p$  is the quantity of product types (*p*) produced leaving the activity during the year measured in tonnes.

- Step 3* Calculate the carbon content in by-product types (*r*) leaving the activity, other than as an emission of greenhouse gas, during the year, measured in tonnes of carbon, as follows:

$$\sum_r CCF_r \times Y_r$$



where:

$\sum_i$  means sum the carbon content values obtained for all by-product types ( $r$ ).

$CCF_r$  is the carbon content factor measured in tonnes of carbon for each tonne of product or by-product types ( $r$ ).

$Y_r$  is the quantity of waste by-product types ( $r$ ) leaving the activity during the year measured in tonnes.

*Step 4*

Calculate the carbon content in the amount of the increase in stocks of inputs, products and waste by-products held within the boundary of the activity during the year in tonnes of carbon as follows:

$$\sum_i CCF_i \times \Delta S_{qi} + \sum_p CCF_p \times \Delta S_{ap} + \sum_r CCF_r \times \Delta S_{yr}$$

where:

$\sum_i$  has the same meaning as in step 1.

$CCF_i$  has the same meaning as in step 1.

$\Delta S_{qi}$  is the increase in stocks of fuel type ( $i$ ) for the activity and held within the boundary of the activity during the year measured in tonnes.

$\sum_p$  has the same meaning as in step 2.

$CCF_p$  has the same meaning as in step 2.

$\Delta S_{ap}$  is the increase in stocks of product types ( $p$ ) produced by the activity and held within the boundary of the activity during the year measured in tonnes.

$\sum_r$  has the same meaning as in step 3.

$CCF_r$  has the same meaning as in step 3.

$\Delta S_{yr}$  is the increase in stocks of waste by-product types ( $r$ ) produced from the operation of the activity and held within the boundary of the activity during the year measured in tonnes.

**Note:** In the event of by-products being disposed of, such material is considered to leave the boundary of the activity.

The inclusion of stock numbers is optional in the event of no accurate figures being available, but reporting entities need to note that possible over-reporting may be a consequence. Hence, it is important for the facilities to monitor material stock levels and stock changes during the reporting period as part of their monitoring plans.

*Step 5*

Calculate the emissions of carbon dioxide released from the operation of the activity during the year measured in CO<sub>2</sub>-e tonnes as follows:

- (a) add the amounts worked out under steps 2, 3 and 4 to work out a new amount (**amount A**);
- (b) subtract amount A from the amount worked out under step 1 to work out a new amount (**amount B**);
- (c) multiply amount B by (44/12) to work out the amount of emissions released from the operation of the activity during a year.

**Note:** Note: Multiplication by (44/12) only applies in the event where the carbon content (t C/t of material) is used in the formulas.

**Method 3: IPCC Tier 3 methodology – Iron and Steel production**

The Tier 3 methodology is similar to the Tier 2 methodology. The difference is that the Tier 3 methodology requires plant specific information on carbon content of all the input, products and by-products in the Iron and Steel Process. In the event of a tier 3 methodology being used for calculating GHG emissions from an iron and steel facility with coke making capacity, all emissions from the iron and steel process arising from the use of coal as a reducing agent fall within the IPPU (process) emission category.

**Example: Estimating emissions from iron and steel production**

Iron and steel production can involve integrated processes such as coke making and steel furnace operations within a facility. The complex carbon and energy flows within the integrated facility can make the estimation of total emissions difficult when a bottom-up approach is taken. The carbon mass balance provides a top-down approach that simplifies the emission estimation process, allowing the emissions to be estimated as a whole, while considering the carbon inputs and outputs to the facility as well as stockpile changes.

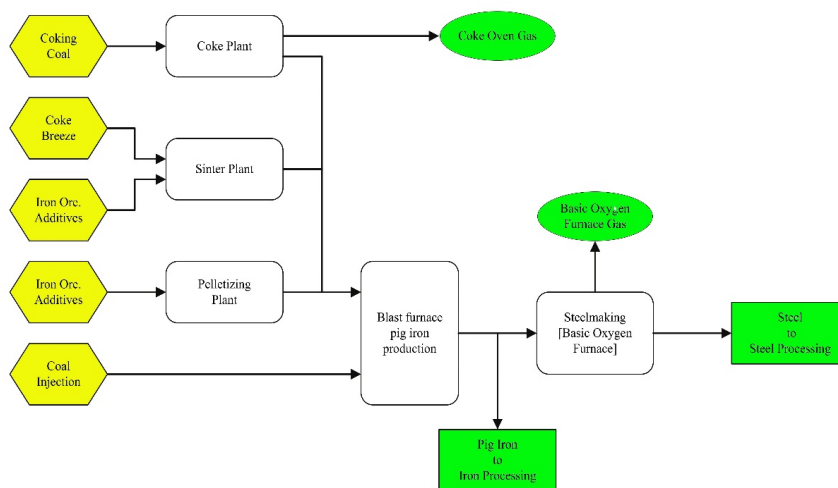

An emission estimation example using the method 3 carbon balance approach is provided below. The example is of an integrated iron and steel facility that uses coke oven coke, coking coal and fuel oil to produce coke, iron and then steel. The facility also produces coal tar and by-products containing carbon, in addition to experiencing fuel stock changes during the year. The relevant data for the integrated iron and steel facility is outlined in the table below.

Table 37:2: Example of data inputs for integrated iron and steel carbon balance

Fuel or product type	Fuels delivered during the year	Products produced and leaving the activity during the year	Change (increase) in stocks during the year	Carbon content factor (CCF)
Coke oven coke		60 000 tonnes	-5 000 tonnes	0.789
Coking coal	750 000 tonnes		3 000 tonnes	0.752
Fuel oil	3 000 kilolitres			0.797
Coal tar		15 000 tonnes	200 tonnes	0.837
Crude steel		920 000 tonnes	1 000 tonnes	0.002

**Step 1:** Calculate the carbon content in fuel types (i) or carbonaceous input material delivered for the activity during the year measured in tonnes of carbon as follows:

Where:

$$\sum_i CCF_i \times Q_i$$

*CCF<sub>i</sub>* is the company specific carbon content factor measured in tonnes of carbon for each appropriate unit of fuel type (i) or carbonaceous input material consumed during the year from the operation of the activity.

*Q<sub>i</sub>* is the quantity of fuel type (i) or carbonaceous input material delivered for the activity during the year measured in tonnes. In this case the quantities of input materials are shown in the table above.

**To calculate the carbon content for the input materials:**

Carbon content of coking coal = (750 000 x 0.752) = 564 000 tonnes of carbon

Carbon content of fuel oil = (3 000 x 0.797) = 2, 391 tonnes of carbon

**Therefore, total carbon = (564 000 + 2 391 = 566 391) tonnes**

**Step 2:** Calculate the carbon content in products (p) leaving the activity during the year measured in tonnes of carbon as follows:

Where:

$$\sum_p CCF_p \times A_p$$

$CCF_p$  is the carbon content factor measured in tonnes of carbon for each tonne of product type (p) produced during the year. In this case the carbon content factor of each product type is shown in the table above:

$A_p$  is the quantity of product types (p) produced leaving the activity during the year measured in tonnes. In this case the quantity of product are shown in the table above:

**To calculate the carbon content for the products leaving the activity during the year:**

Carbon Content of crude steel =  $(920\ 000 \times 0.002) = 1\ 840$  tonnes of carbon

Carbon Content of coke oven coke =  $(60\ 000 \times 0.789) = 47\ 340$  tonnes of carbon

Carbon Content of coal tar =  $(15\ 000 \times 0.837) = 12\ 555$  tonnes of carbon

**Therefore, total carbon =  $(1\ 840 + 47\ 340 + 12\ 555) = 61\ 735$  tonnes**

Step 3 Calculate the carbon content in by-product types (r) leaving the activity, other than as an emission of greenhouse gas, during the year, measured in tonnes of carbon, as follows:

Where:

$$\sum_r CCF_r \times Y_r$$

$CCF_r$  is the carbon content factor measured in tonnes of carbon for each tonne of by-product types (r).

$Y_r$  is the quantity of by-product types (r) leaving the activity during the year measured in tonnes. In this case the quantities of by-products are:

- slag, of which 230 000 tonnes was produced. The facility estimated the carbon content of the slag was 0.0005 tonnes per tonne of slag.
- Other non-oxidised carbon sources (measurement) estimated at 1 500 tonnes.

**To calculate the carbon content for the waste products leaving the activity during the year:**

Carbon Content of slag =  $(230\ 000 \times 0.0005) = 115$  tonnes of carbon

Carbon Content of other non-oxidised carbon = 1 500 tonnes of carbon

**Therefore, total carbon =  $(115 + 1\ 500) = 1\ 615$  tonnes**

Step 4 Calculate the carbon content in the amount of the increase in stocks of inputs, products and waste by products held within the boundary of the activity during the year in tonnes of carbon as follows:

Where:

$$\sum_i CCF_i \times \Delta S_{qi} + \sum_p CCF_p \times \Delta S_{ap} + \sum_r CCF_r \times \Delta S_{yr}$$

$CCF_i$  has the same meaning as in step 1.

$S_{qi}$  is the increase in stocks of fuel type (i) for the activity and held within the boundary of the activity during the year measured in tonnes. In this case the quantities of increases in stocks are shown in the table above:

**To calculate the carbon content for increase of fuel types**

Carbon content of coke oven coke =  $(-5000 \times 0.789) = -3,945$  tonnes of carbon

Carbon content of coking coal =  $(3000 \times 0.752) = 2,256$  tonnes of carbon

**Therefore, total carbon =  $(-3\ 945 + 2\ 256) = -1689$  tonnes**

$CCF_p$  has the same meaning as in step 2.

$\Delta S_{ap}$  is the increase in stocks of product types (p) produced by the activity and held within the boundary of the activity during the year measured in tonnes. In this case the quantities of product types shown in the table above:

**To calculate the carbon content for increase in stock of product type:**

Carbon content of coal tar =  $(200 \times 0.837) = 167.4$  tonnes of carbon

Carbon content of crude steel =  $(1000 \times 0.002) = 2$  tonnes of carbon

**Therefore, total carbon =  $(167.4 + 2) = 169.4$  tonnes**

$CCF_r$  has the same meaning as in step 3.

$\Delta S_{yr}$  is the increase in stocks of by-product types (r) produced from the operation of the activity and held within the boundary of the activity during the year measured in tonnes.

**There was no change in by-product stock produced and held during the year.**

**To calculate the total carbon contained in the change of stock:**

Carbon content of increase in fuel types =  $-1689$  tonnes

Carbon content of increase in product types =  $169.4$  tonnes

Carbon content of increase in by-products =  $0$  tonnes

**Therefore, total carbon =  $(-1\ 689 + 169.4 + 0) = -1\ 519.6$  tonnes**

Step 5 Calculate the emissions of carbon dioxide released from the operation of the activity during the year measured in CO<sub>2</sub> e tonnes as follows:

- (a) add the amounts worked out under steps 2, 3 and 4 to work out a new amount (amount A);

**In this case A is:**

$$= 61\,735 + 1,615 + -1\,519.6$$

$$= 61\,830.4 \text{ tonnes of carbon}$$

- (b) subtract amount A from the amount worked out under step 1 to work out a new amount (amount B);

**In this case:**

$$= 566\,391 - 61\,830.4$$

$$= 504\,560.6 \text{ tonnes of carbon}$$

- (c) multiply amount B by (44/12) to work out the amount of emissions released from the operation of the activity during a year.

$$= 504\,730 \times (44/12)$$

$$= 1\,850\,055.53 \text{ tonnes CO}_2\text{e}$$

**Therefore, total carbon balance CO<sub>2</sub> emissions from the source = 1 850 055.53 tonnes. In this tier 3 mass balance example for an integrated iron and steel plant where coke is also produced, all emissions are considered to be process emissions. Differentiation between energy (small amount) and process emissions is not possible.**

### Metallurgical coke production emissions

The IPCC Guidelines outline three tiers for calculating CO<sub>2</sub> emissions and two tiers for calculating CH<sub>4</sub> emissions from coke production. Metallurgical coke is produced either at the iron and steel facility (onsite) or at separate facilities (offsite). The Tier 1 method multiplies default emission factors by tonnes of coke produced. If the Tier 1 approach is used, emissions should be reported in the Energy Sector.

$$E_{CO_2} = \text{Coke} \cdot EF_{CO_2}^{21}$$

$$E_{CH_4} = \text{Coke} \cdot EF_{CH_4}^{22} \text{ (To be reported in Energy Sector under 1B1c)}$$

Where:

$$E_{CO_2} \text{ or } E_{CH_4} = \begin{matrix} \text{emissions of CO}_2 \text{ or CH}_4 \text{ from coke production, tonnes CO}_2 \text{ or} \\ \text{tonnes} & \text{CH}_4 \end{matrix}$$

$$\text{Coke} = \text{quantity of coke produced for internal use at iron and steel plants or external use, tonnes}$$

$$EF = \text{emission factor, tonnes CO}_2\text{/tonne coke production or tonnes CH}_4\text{/tonne coke production}$$

<sup>21</sup> CO<sub>2</sub> emissions factor available in Annexure C of this document

<sup>22</sup> CH<sub>4</sub> emission factor available in Annexure C of this document

Note: The Tier 1 method assumes that all the coke oven by-products are transferred off site and that all of the coke oven gas produced is burned on site for energy recovery.

Tier 2 estimates CO<sub>2</sub> emissions from onsite coke production separately from off-site production. It produces a more accurate estimate than Tier 1 because it considers the actual quantity of inputs into and outputs rather than making assumptions.

### 37.3. Activity Data

For details on choice of activity data please refer to section 4.2.2.4 in Volume 3 Chapter 4 of the 2006 IPCC Guidelines.

### 37.4. Emission Factors

For details on choice of emission factors please refer to section 4.2.2.3 in Volume 3 Chapter 4 of the 2006 IPCC Guidelines.

In the event of a GHG being recovered from an off-gas stream for further utilisation beyond the reporting boundary, such quantity of GHG shall be subtracted from a company's calculated GHG emissions as it is not emitted to atmosphere. The activity that utilises such GHG beyond the reporting boundary shall be responsible for the reporting thereof if emitted to atmosphere.

The IPCC guidelines (Volume 3, Chapter 4, 2006) do not provide methodologies for N<sub>2</sub>O emissions, as the quantities are likely to be small. Till country specific methods are researched, the N<sub>2</sub>O emissions need not be reported for the iron and steel sector and coke making activities.

A company can apply to revise emission factors which can be submitted to the competent authority for review as per section 10(2) of the Regulations.

Table 37:3 summarises the default carbon content of materials used in Iron and Steel production that can be applied in the Tier 2 methodology. For a Tier 3 methodology, these CCFs will have to be determined at plant-specific level.

**Table 37:3: Carbon content factors for the tier 2 methodology (IPCC 2006)**

Process Materials	Carbon Content (kg C/kg)
Blast furnace Gas	0.17
Charcoal*	0.91
Coal <sup>23</sup>	0.67
Coal Tar	0.62

<sup>23</sup> Assumed other bituminous coal

Process Materials	Carbon Content (kg C/kg)
Coke	0.83
Coke Oven Gas	0.47
Coking Coal	0.73
Direct Reduced Iron (DRI)	0.02
Dolomite	0.13
EAF Carbon Electrodes <sup>24</sup>	0.82
EAF Charge Carbon <sup>25</sup>	0.83
Fuel Oil <sup>26</sup>	0.86
Gas Coke	0.83
Hot Briquetted Iron	0.02
Limestone	0.12
Natural Gas	0.73
Oxygen Steel Furnace Gas	0.35
Petroleum Coke	0.87
Purchased Pig Iron	0.04
Scrap Iron	0.04
Steel	0.01

<sup>24</sup> Assumed 80 percent petroleum coke and 20 percent coal tar

<sup>25</sup> Assumed coke oven coke

<sup>26</sup> Assumed gas/diesel fuel



### 38. Ferrous Alloys and Other Metals Production

Ferrous alloys are defined as alloys of iron with some element other than carbon. Silicon metal production is usually included in the ferrous alloy group because the silicon metal production process is quite similar to the ferrosilicon process. Ferrous alloy production involves a metallurgical reduction process that results in significant CO<sub>2</sub> emissions. In cases where a tier 2/3 method is used to quantify process CO<sub>2</sub> emissions, then CH<sub>4</sub> emissions should not be estimated separately from the carbon balance method used. The tier 2 methodology assumes an oxidation factor of 1 for all carbon containing process materials that are oxidised to form CO<sub>2</sub>.

A specific methodology to determine the emissions associated with ferrous alloy production is detailed in Volume 3, Chapter 4.3 of the 2006 IPCC guidelines. The following subsection details with how direct emissions sources are linked to the relevant IPCC Source Categories for the GHG Reporting Regulations.

This section also includes guidance for reporting emissions produced from Other Metal Production (IPCC code 2C7 Other). Any metal production that does not fall under iron and steel production, ferrous alloys production, aluminium production, magnesium production, lead production, or zinc production must be included under 2C7 Other.

#### 38.1. IPCC Classification

The direct emissions associated with ferrous alloy and other metal production are related to the IPCC source categories for the GHG Reporting Regulations in table 34.1 below.

**Table 38.1: Direct emissions for ferrous alloy and other metal production linked to the IPCC Source Category for the GHG Reporting Regulations.**

Sector	Relevant IPCC code/s	Definition	Relevant IPCC Gases	Tier	Methodology reference	Transitional arrangements
Ferro-alloy and other metal production	1A2a	Fuel combustion activities from a non-specified industry.	CO <sub>2</sub>	2 or 3	Section 12	Yes
			CH <sub>4</sub>	1, 2 or 3	Section 12	No
			N <sub>2</sub> O	1, 2 or 3	Section 12	No
	1A1ci	Emissions arising from fuel combustion for the production of coke, brown coal briquettes and patent fuel as well as recovery of CO syngas	CO <sub>2</sub>	2 or 3	Section 12	Yes
			CH <sub>4</sub>	1, 2 or 3	Section 12	No
			N <sub>2</sub> O	1, 2 or 3	Section 12	No
	1B1c	Charcoal Production	CH <sub>4</sub>	1, 2 or 3	Section 12	No
	2C2 <sup>27</sup>	Ferrous alloy production	CO <sub>2</sub>	2 or 3	Section 38	Yes
			CH <sub>4</sub>	1,2 or 3	Section 36	No

<sup>27</sup> If biomass-based materials are used as feedstock in the process of manufacturing Ferro-alloys, CO<sub>2</sub> emissions from the use of such material shall be treated as memo items.

Greenhouse gas emissions arising due to the use of fuels as reducing agent or for other non-energy use of fuels must be reported as part of process emissions under 2C2 or 2C7.

Please note that the table above details the sectors that should be covered as a minimum. If there are other emission sources, under control of the data provider, that still need to be reported please report them under the relevant categories as listed in Table 5:2 of this document.

### 38.2. Methodology

GHG emissions stem primarily from carbon monoxide, which is produced in the highly reducing environment of the arc furnace and is subsequently converted to CO<sub>2</sub> once it is released into the atmosphere. In addition to emissions originating from reducing agents and electrodes the calcination of carbonate fluxes, such as limestone or dolomite, contributes to the emission of GHGs. The quantity of emissions generated during production depend on type of reducing agent used (char, coke, etc.) in the furnace.

Care should be taken with the calculation of emissions from renewable sources of wood and charcoal, as the associated emission factor is zero.

There are three Tiers that can be used to calculate emissions from ferroalloy and other metals production:

- Tier 1: Uses annual production output in tonnes multiplied by the IPCC default emission factor for the specific ferroalloy product.
- Tier 2: Uses production output multiplied by production based, raw material specific emission factors or country specific carbon contents (C kg/kg material).
- Tier 3: Mass balance approach calculations based on amounts and analyses of reducing agents.

A schematic representation of the emissions pathway associated with ferroalloy production is presented in Figure 38:1.

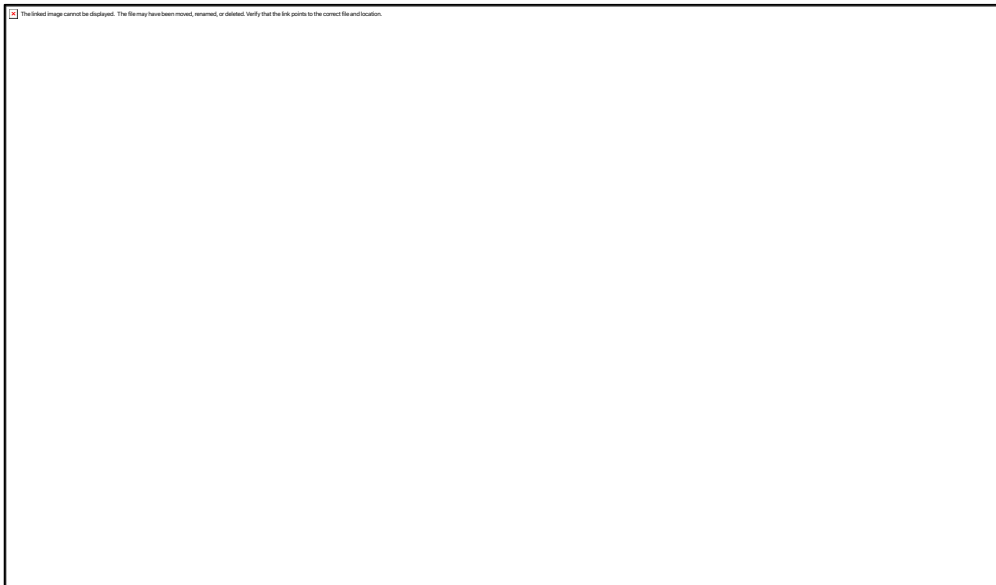

**Figure 38:1: Ferroalloy production process pathway**

Emissions of CO<sub>2</sub> occur during ferroalloy production as a result of the use of carbon reductants such as coke and the oxidation of a fossil fuel electrode.

Methane and nitrous oxide emissions arising from the combustion of reductants should be estimated using methods described in section 2.3 in Volume 2, Chapter 2 – of the 2006 IPCC Guidelines.

### **38.3. Application**

In this section:

**Ferroalloy** means an alloy of one or more elements with iron including, but not limited to, any of the following:

- ferrochrome
- ferromanganese
- ferromolybdenum
- ferronickel
- ferrosilicon
- ferrotitanium
- ferrotungsten
- ferrovanadium

#### **Method 1: IPCC Tier 1 - Ferroalloy metal production**

This is the simplest estimation method. CO<sub>2</sub> emissions are determined by multiplying default emission factors by ferroalloy product type. Tier-1 emission factors are provided in Annexure C of this document.

Emissions from production of ferroalloys result due to the high temperature heating of raw ore, carbon materials. CO<sub>2</sub> is released from the use of a reducing agent, and can be estimated from the Tier 1 approach as follows:

$$\text{ECO}_2 \text{ emissions} = [\text{MPi} \times \text{EFi}]$$

Where:

ECO<sub>2</sub> = CO<sub>2</sub> emissions, tonnes

MPi = production of ferroalloy type *i*, tonnes

EFi = generic emission factor for ferroalloy type *i*, tonnes CO<sub>2</sub>/tonne specific ferroalloy product, Table 4.5 and 4.6 of 2006 IPCC Guidelines V3 Ch4.

A factor of 1000 to convert from kilograms to Gigagrams of the relevant Greenhouse gas.

The ferroalloy production process can also result in methane (CH<sub>4</sub>) emissions when carbon containing materials are heated in the furnace. Methane emissions are estimated as follows;

$$\text{ECH}_4 = [\text{MPi} \times \text{EFi}]$$

Where:

ECH<sub>4</sub> = CH<sub>4</sub> emissions, tonnes

MPi = production of Si-alloy *i*, tonnes

EFi = generic emission factor for Si-alloy *i*, kg CH<sub>4</sub>/ tonne specific Si-alloy product, Table 4.7 and 4.8 of 2006 IPCC Guidelines

### Method 2: IPCC Tier 2 — Ferroalloy metal production

Method 1, based on a carbon mass balance approach, is:

*Step 1* Work out the carbon content in fuel types (*j*) or carbonaceous input material delivered for the activity during the year, measured in tonnes of carbon, as follows:

$$\sum_j \text{CCF}_j \times Q_j$$

Where:

$\sum_j$  means the sum of the carbon content values obtained for all fuel types (*j*) or carbonaceous input material.

**CCF<sub>j</sub>** is the carbon content factor mentioned in table 37 and in Volume 2, Chapter 1 of the 2006 IPCC guidelines, measured in tonnes of carbon, for each appropriate unit of fuel type (*j*) or carbonaceous input material consumed during the year from the operation of the activity.

**Q<sub>j</sub>** is the quantity of fuel type (*j*) or carbonaceous input material delivered for the activity during the year, measured in tonnes.

*Step 2* Work out the carbon content in products (*p*) leaving the activity during the year, measured in tonnes of carbon, as follows:

$$\sum_p \text{CCF}_p \times A_p$$

Where:

$\sum_p$  means the sum of the carbon content values obtained for all product types ( $p$ ).

$CCF_p$  is the carbon content factor, measured in tonnes of carbon, for each tonne of product type ( $p$ ) produced during the year.

$A_p$  is the quantity of product types ( $p$ ) produced leaving the activity during the year, measured in tonnes.

*Step 3* Work out the carbon content in waste by-product types ( $r$ ) leaving the activity, other than as an emission of greenhouse gas, during the year, measured in tonnes of carbon, as follows:

$$\sum_r CCF_r \times Y_r$$

where:

$\sum_r$  means the sum of the carbon content values obtained for all waste by-product types ( $r$ ).

$CCF_r$  is the carbon content factor, measured in tonnes of carbon, for each tonne of waste by-product types ( $r$ ).

$Y_r$  is the quantity of waste by-product types ( $r$ ) leaving the activity during the year, measured in tonnes.

*Step 4* Work out the carbon content in the amount of the change in stocks of inputs, products and waste by-products held within the boundary of the activity during the year, measured in tonnes of carbon, as follows:

$$\sum_i CCF_i \times \Delta S_{qi} + \sum_p CCF_p \times \Delta S_{ap} + \sum_r CCF_r \times \Delta S_{yr}$$

where:

$\sum_i$  has the same meaning as in step 1.

$CCF_i$  has the same meaning as in step 1.

$\Delta S_{qi}$  is the change in stocks of fuel type ( $i$ ) for the activity and held within the boundary of the activity during the year, measured in tonnes.

$\sum_p$  has the same meaning as in step 2.

$CCF_p$  has the same meaning as in step 2.

$\Delta S_{ap}$  is the change in stocks of product types ( $p$ ) produced by the activity and held within the boundary of the activity during the year, measured in tonnes.

$\sum_r$  has the same meaning as in step 3.

$CCF_r$  has the same meaning as in step 3.

$\Delta S_{yr}$  is the change in stocks of waste by-product types ( $r$ ) produced from the operation of the activity and held within the boundary of the activity during the year, measured in tonnes.

- Step 5* Work out the emissions of carbon dioxide released from the operation of the activity during the year, measured in CO<sub>2</sub>-e tonnes, as follows:
- add the amounts worked out under steps 2, 3 and 4 to work out a new amount (**amount A**)
  - subtract amount A from the amount worked out under step 1 to work out a new amount (**amount B**)
  - multiply amount B by (44/12) to convert from carbon to carbon dioxide assuming 100% oxidation

Please see Table 33.2 for default carbon content factors (CCFs) of common materials used in the ferroalloys industry.

### **Method 3: IPCC Tier 3 — Ferroalloy metal production**

Tier 3 methodology is similar to the Tier 2 methodology. The difference is that the Tier 3 methodology requires plant specific information on carbon content of all the input, products and by-products in the ferroalloy process.

#### **38.4. Activity Data**

For details on choice of activity data please refer to section 4.3.2.3 in Volume 3, Chapter 4 of the 2006 IPCC Guidelines.

#### **38.5. Emission Factors**

For details on choice of emission factors please refer to section 4.3.2.2 in Volume 3, Chapter 4 of the 2006 IPCC Guidelines.

## 39. Aluminium Production

Worldwide primary aluminium is produced exclusively by the Hall-Heroult electrolytic process. As part of this process electrolytic reduction cells differ in the form and configuration of the carbon anode and alumina feed system and belong to one of four technology types:

- Centre-Worked Prebake (CWPB)
- Side-Worked Prebake (SWPB)
- Horizontal Stud Søderberg (HSS)
- Vertical Stud Søderberg (VSS)

The most significant process emissions from aluminium production are:

- CO<sub>2</sub> emissions from the consumption of carbon anodes in the reaction to convert aluminium oxide to aluminium metal.
- Perfluorocarbons (PFCs) emissions of CF<sub>4</sub> and C<sub>2</sub>F<sub>6</sub> during anode effects.

### 39.1. IPCC Classification

The table below details the relationship between direct emission sources and the corresponding IPCC source categories for reporting under the National GHG Reporting Regulations.

Table 39:1: IPCC classification of aluminium production

Sector	Relevant IPCC code/s	Definition	Relevant IPCC Gases	Tier	Methodology reference	Transitional arrangements
Aluminium Production	1A2b	Fuel combustion activities from non-ferrous metals.	CO <sub>2</sub>	2 or 3	Section 12	Yes
			CH <sub>4</sub>	1, 2 or 3	Section 12	No
			N <sub>2</sub> O	1, 2 or 3	Section 12	No
	2C3	Aluminium production	CO <sub>2</sub>	2 or 3	Section 39	Yes
			CF <sub>4</sub>	2 or 3	Section 39	Yes
			C <sub>2</sub> F <sub>6</sub>	2 or 3	Section 39	Yes

Please note that the table above details the sectors that should be covered as a minimum. If there are other emission sources, under control of the data provider, that still need to be reported please report them under the relevant categories as listed in Section 5 of this document.

## 39.2. Methodology

### CO<sub>2</sub> emissions from Aluminium production

#### Method 1: IPCC Tier 1 method –CO<sub>2</sub>

The Tier 1 method for calculating CO<sub>2</sub> emissions uses only broad cell technology characterisations (Prebake or Søderberg) as a lower order estimate of CO<sub>2</sub> emissions from aluminium production. Metal production from the Prebake process is multiplied by the prebake technology specific emission factor and then added to metal production from the Søderberg process multiplied by the Søderberg technology specific emission factor. The Tier-1 methodology, though known to have uncertainties, is widely used for calculating CO<sub>2</sub> emissions, as shown below:

$$E_{CO_2} = [EF_P \cdot MP_P + EF_S \cdot MP_S]$$

Where:

$E_{CO_2}$  = CO<sub>2</sub> emissions from anode and/or paste consumption, tonnes CO<sub>2</sub>

$EF_P$  = Prebake technology specific emission factor (tonnes CO<sub>2</sub>/tonne aluminium produced)

$MP_P$  = metal production from Prebake process (tonnes Al)

$EF_S$  = Søderberg technology specific emission factor (tonnes CO<sub>2</sub>/tonne aluminium produced)

$MP_S$  = metal production from Søderberg process (tonnes Al)

A factor of 1000 to convert from tonnes to Gigagrams of the relevant Greenhouse gas

#### Method 2: IPCC Tier 2 method – CO<sub>2</sub>

For the Tier 2 and Tier 3 method a mass balance approach is used that assumes that the carbon content of net anode consumption or paste consumption is ultimately emitted as CO<sub>2</sub>. The Tier 2 methods for both Prebake and Søderberg processes make use of typical industry values for impurities.

#### Method 3: IPCC Tier 3 method – CO<sub>2</sub>

Method 3 is similar to method 2 but uses actual concentrations of impurities.



### Tetrafluoromethane (CF<sub>4</sub>) from Aluminium production

#### Method 1: IPCC Tier 1 methodology - CF<sub>4</sub> and C<sub>2</sub>F<sub>6</sub>

Method 1 can be used to calculate PFC emissions for all the four types of aluminium production technologies (CWPB, SWPB, VSS and HSS).

Tier 1 PFC emissions are estimated as follows:

$$ECF_4 = [EFCF_{4i} \times MP_i]$$

$$EC_2F_6 = [EFC_2F_{6i} \times MP_i]$$

Where:

$ECF_4$  = emissions of CF<sub>4</sub> from aluminium production, tonnes CF<sub>4</sub>

$EC_2F_6$  = emissions of C<sub>2</sub>F<sub>6</sub> from aluminium production, tonnes C<sub>2</sub>F<sub>6</sub>

$EFCF_{4,i}$  = default emission factor by cell technology type *i* for CF<sub>4</sub>, kg CF<sub>4</sub>/tonne Al

$EFC_2F_{6,i}$  = default emission factor by

cell technology type *i* for C<sub>2</sub>F<sub>6</sub>, kg C<sub>2</sub>F<sub>6</sub>/tonne Al

$MP_i$  = metal production by cell technology type *i*, tonnes Al

Default emission factors for CF<sub>4</sub> and C<sub>2</sub>F<sub>6</sub> emissions can be obtained from Annexure C of this document.

#### Method 2: IPCC Tier 2 methodology - CF<sub>4</sub> and C<sub>2</sub>F<sub>6</sub>

Method 2 is the Tier 2 method for estimating perfluorocarbon emissions as set out in the 2006 IPCC Guidelines (V3, Ch4). For detailed activity data requirements, please see table 35.2 below.

#### Method 3: IPCC Tier 2 methodology - CF<sub>4</sub> and C<sub>2</sub>F<sub>6</sub>

Method 3 is the Tier 3 method for estimating facility specific perfluorocarbon emissions as set out in the 2006 IPCC Guidelines (V3, Ch4). For detailed activity data requirements, please see **Table 39:2** below.

### 39.3. Activity Data

For details on choice of activity data, such as production data, please refer to section 4.4.2.5 of Volume 3, Chapter 4 of the 2006 IPCC Guidelines.

**Table 39:2: Aluminium production emissions data requirements for CO<sub>2</sub>, CF<sub>4</sub> and C<sub>2</sub>F<sub>6</sub>**

Tier 1	Tier 2/Tier 3	Other information
i) Amount of aluminium produced, per annum	<p><i>For Prebake smelter</i></p> i) Amount of aluminium produced per annum ii) net prebaked anode consumption per tonne of aluminium iii) Sulphur content in baked anodes iv) Ash content in baked anodes v) Initial weight of green anodes vi) Hydrogen content in green anodes vii) Quantity of baked anode production per annum viii) Quantity of waste tar collected, per annum ix) Packing coke consumption, tonnes/tonne of baked anode x) Sulphur content in packing coke xi) Ash content in packing coke <p><i>For Soderberg cells (VSS and HSS):</i></p> i) Total aluminium production, per annum ii) Total paste consumption, per annum iii) Binder content in paste iv) Sulphur content in pitch v) Emissions of cyclohexane soluble matter, kg/tonne Al vi) Ash content in pitch vii) Hydrogen content in pitch viii) Sulphur content in calcined coke ix) Ash content in calcined coke x) Carbon in skimmed dust from Soderberg cells, tonnes C/tonne Al	i) Technology type (CWPB, SWPB, HSS or VSS). ii) Information on data quality and uncertainty estimates
<p><i>For PFCs emissions;</i></p> i) Amount of aluminium production by cell technology type, per annum	<p><i>For PFCs emissions;</i></p> <p><i>By slope method;</i></p> i) Amount of aluminium production by cell technology type, per annum ii) Anode effect minutes per cell-day, AE-Mins/cell-day <p><i>By Overvoltage method;</i></p> i) Amount of aluminium production by cell technology type, per annum ii) Anode effect overvoltage, mV iii) Aluminium production process current efficiency expressed, percent	

**39.4. Emission Factors**

For details on choice of emission factors please refer to section 4.4.2.2 of Volume 3, Chapter 4 of the 2006 IPCC Guidelines. These emissions factors are also summarised in Annexure C of this document.

## 40. Magnesium Production

The magnesium industry has numerous potential emission sources and gases. The emissions in the magnesium production process depend on the raw material used for primary magnesium metal production and/or the type of cover gas mixture used in the casting and recycling foundries to prevent oxidation of molten magnesium. GHG emissions are associated with primary, and secondary magnesium metal production and casting operations but a data provider only has to report on direct emissions over which they exercise operational control.

There are two types of magnesium, namely primary and secondary magnesium.

Primary magnesium refers to metallic magnesium derived from mineral sources. Dolomite, magnesite, carnalite, serpentine, brines and seawater are the raw materials used in the production of primary magnesium. The processing of carbonate raw materials releases CO<sub>2</sub> during the manufacturing process.

Secondary magnesium production includes the recovery and recycling of metallic magnesium from a variety of magnesium containing scrap materials.

All molten magnesium spontaneously burns in the presence of atmospheric oxygen.

### 40.1. IPCC Classification

The table below details the relationship between direct emission sources and the corresponding IPCC source categories for reporting under the National GHG Reporting Regulations.

**Table 40:1: IPCC classification of emissions for magnesium production**

Sector	Relevant IPCC code/s	Definition	Relevant IPCC Gases	Tier	Methodology reference	Transitional arrangements
Magnesium Production	1A2b	Fuel combustion activities from a non-specified industry.	CO <sub>2</sub>	2 or 3	Section 12	Yes
			CH <sub>4</sub>	1, 2 or 3	Section 12	No
			N <sub>2</sub> O	1, 2 or 3	Section 12	No
	2C4	Magnesium production	CO <sub>2</sub>	2 or 3	Section 40	Yes
			SF <sub>6</sub>	1, 2 or 3	Section 40	No

Please note that the table above details the sectors that should be covered as a minimum. If there are other emission sources, under control of the data provider, that still need to be reported please report them under the relevant categories as listed in Table 5:2of this document.

## 40.2. Methodology

### CO<sub>2</sub> emissions from primary Magnesium production

#### Method 1: IPCC Tier 1 — Magnesium production – CO<sub>2</sub>

The Tier 1 method for estimating emissions from magnesium production is based on primary production data and default emission factors.

$$ECO_2 = [(Pd \cdot Efd) + (Pmg \cdot Efm_g)]$$

Where:

ECO<sub>2</sub> = CO<sub>2</sub> emissions from primary magnesium production, tonnes

Pd = primary magnesium production from dolomite, tonnes

Pmg = primary magnesium production from magnesite, tonnes

EF<sub>d</sub> = Default emission factor for CO<sub>2</sub> emissions from primary magnesium production from dolomite, tonne CO<sub>2</sub>/tonne primary Mg produced

EF<sub>m<sub>g</sub></sub> = Default emission factor for CO<sub>2</sub> emissions from primary magnesium production from magnesite, tonne CO<sub>2</sub>/tonne primary Mg produced

#### Method 2: IPCC Tier 2 — Magnesium production – CO<sub>2</sub>

The Tier 2 method for determining CO<sub>2</sub> emissions from primary magnesium involves collecting company/plant specific emission factors in addition to company specific production data.

#### Method 3: IPCC Tier 3 — Magnesium production – CO<sub>2</sub>

The Tier 3 method is based on actual measured CO<sub>2</sub> emissions data from individual primary magnesium facilities.

For detailed equations and guidance please refer to Magnesium Production section 4.5 in Volume 3, Chapter 4 of the 2006 IPCC Guidelines.

### SF<sub>6</sub> emissions from primary Magnesium production

#### Method 1: IPCC Tier 1 — Magnesium production – SF<sub>6</sub>

The Tier 1 method for estimating emissions of SF<sub>6</sub> from magnesium production is based on primary production data, and default emission factors.

$$ESF_6 = MG_c \cdot EF_{SF_6} / 1000$$

Where;

$ESF_6$  =  $SF_6$  emissions from primary magnesium production, tonnes

$MGc$  = total amount of magnesium casting or handling in the country, tonnes

$EF_{SF_6}$  = Default emission factor for  $SF_6$  emissions from magnesium casting, kg  $SF_6$ /tonne Mg casting

A factor of 1000 to convert from kilograms to tonnes of the relevant greenhouse gas

**Method 2: IPCC Tier 2 — Magnesium production –  $SF_6$**

The Tier 2 method for determining  $SF_6$  emissions from primary and secondary magnesium involves collecting company/plant specific amounts of  $SF_6$  used in the magnesium casting process and assuming that all the  $SF_6$  used is released into the atmosphere.

**Method 3: IPCC Tier 3 — Magnesium production –  $SF_6$**

The Tier 3 method is based on actual measured  $SF_6$  emissions data from individual primary magnesium facilities.

For detailed equations and guidance please refer to Magnesium Production section 4.5 in Volume 3, Chapter 4 of the 2006 IPCC Guidelines.

**40.3. Activity Data**

Activity data requirements for Magnesium production are summarised in Table 40:2 below.

**Table 40:2: Activity data requirements for Magnesium production**

Tier 1	Tier 2	Other information
<i>Primary magnesium production</i> i) Quantity of magnesium produced from dolomite per annum (national level) ii) Quantity of magnesium produced from magnesite per annum (national level)	<i>Primary magnesium production</i> i) Quantity of magnesium produced from dolomite per annum (plant specific) ii) Quantity of magnesium produced from magnesite per annum (plant specific) iii) Plant-specific emission factor for $CO_2$ emissions from primary magnesium production, tonne $CO_2$ /tonne primary Mg produced	i) Raw material used (dolomite, magnesite) ii) Information on production technology, whether magnesium casting takes place iii) Type of cover gas used in production ( $SF_6$ , HFC-134a, FK 5-1-12 and decomposition products (e.g., PFCs) iv) Information on data quality and uncertainty estimates
<i>Magnesium casting process</i> i) Total amount of magnesium casting per annum	<i>Magnesium casting process</i> i) Consumption of $SF_6$ in magnesium smelters and foundries (to be collected from each plant)	

**40.4. Emission Factors**

For details on choice of emission factors please refer to section 4.5.2.2 of Volume 3, Chapter 4 of the 2006 IPCC Guidelines. Emission factors are also presented in Annexure C of this document.

## 41. Lead Production

Lead is produced following one of two processes: sintering and smelting or only smelting. The variation in the process results in different emissions being produced. During the sintering process SO<sub>2</sub> and CO<sub>2</sub> emissions are produced. The emissions from the smelting process depend on the type of furnace used for smelting, and the reducing agent used. CO<sub>2</sub> emissions are the main emissions produced.

In addition, the secondary production of refined lead from recycled products also produces emissions and is to be included in this category. The emissions from the secondary production of lead also vary depending on the furnace and reducing agent used, with CO<sub>2</sub> being the main emission produced.

### 41.1. IPCC Classification

All direct emissions of a company should be reported. The emissions produced within the furnace, along with the emissions from the combustion of fuel used in the sintering and smelting process, should be reported under the IPCC category "2C5 Lead Production".

The IPCC 2006 Guidelines give guidance on where the various emissions should be reported. This has been summarised specifically for lead production companies in the table below.

Table 41:1 IPCC Classification of emissions for lead production

Sector	Relevant IPCC code/s	Definition	Relevant IPCC Gases	Tier	Methodology reference	Transitional arrangements
Lead Production	1A2b	Fuel combustion activities from non-ferrous metals.	CO <sub>2</sub>	2 or 3	Section 12	Yes
			CH <sub>4</sub>	1, 2 or 3	Section 12	No
			N <sub>2</sub> O	1, 2 or 3	Section 12	No
	2C5	Lead production	CO <sub>2</sub>	2 or 3	Section 41	Yes

Please note that the table above details the sectors that should be covered as a minimum. If there are other emission sources, under control of the data provider, that still need to be reported please report them under the relevant categories as listed in Table 5:2 of this document.

### 41.2. Methodology

The Tier 1 approach is based on production values and default emission factors.

#### Method 1: IPCC Tier 1 — Lead production

Tier 1 method provides the simplest estimation method by multiplying default emission factors by lead production.

$$\text{CO}_2 = [(\text{DS} \cdot \text{EFDS}) + (\text{ISF} \cdot \text{EFISF}) + (\text{S} \cdot \text{EFS})]$$

Where;

ECO<sub>2</sub> = CO<sub>2</sub> emissions from lead production, tonnes

DS = quantity of lead produced by Direct Smelting, tonnes

EFDS = emission factor for Direct Smelting, tonne CO<sub>2</sub>/tonne lead product

ISF = quantity of lead produced from the Imperial Smelting Furnace, tonnes

EFISF = emission factor for Imperial Smelting Furnace, tonne CO<sub>2</sub>/tonne lead product

S = quantity of lead produced from secondary materials, tonnes

EFS = emission factor for secondary materials, tonne CO<sub>2</sub>/tonne lead product

The CO<sub>2</sub> emission factors to be used can be obtained from Table 4.21 in Volume 3, Chapter 4 of the 2006 IPCC Guidelines.

A factor of 1000 to convert from tonnes to Gigagrams of the relevant Greenhouse gas

### Method 2: IPCC Tier 2 — Lead production

The Tier 2 approach can be used when plant specific activity data is available, but the carbon content of the materials are unknown and thus default carbon content figures are used.

Table 41:2: Tier 2 - Material-specific carbon content for lead production (IPCC 2006, Volume 3, Chapter 4, Table 4.22)

Process Materials	Carbon Content (kg carbon/kg )
Blast Furnace Gas	0.1
Charcoal*	0.9
Coal <sup>28</sup>	0.6
Coal Tar	0.6
Coke	0.8
Coke Oven Gas	0.4
Coking Coal	0.7
EAF Carbon Electrodes <sup>29</sup>	0.8
EAF Charge Carbon <sup>30</sup>	0.8
Fuel Oil <sup>31</sup>	0.8

<sup>28</sup> Assumed other bituminous coal

<sup>29</sup> Assumed 80 percent petroleum coke and 20 percent coal tar

<sup>30</sup> Assumed coke oven coke

<sup>31</sup> Assumed gas/diesel fuel



Process Materials	Carbon Content (kg carbon/kg )
Gas Coke	0.8
Natural Gas	0.7
Petroleum Coke	0.8

### Method 3: IPCC Tier 3 — Lead production

The Tier 3 approach is similar to the Tier 2 methodology. The difference is that plant-specific carbon contents are used instead of the default carbon contents provided in the 2006 IPCC Guidelines. The carbon content measurement regime followed should be consistent with the requirements of section 4.6 of the 2006 IPCC Guidelines.

#### 41.3. Activity data

For Tier 1 the lead production values are used in the calculation.

For both the Tier 2 and Tier 3 quantification approach the consumption data of reducing agents and process materials used in the lead production process are required.

For the Tier 3 quantification approach, the plant-specific carbon content of all reducing agents and other carbonaceous materials in the lead production process is used.

Further guidance on activity data can be found in Section 4.6.2.3 of the IPCC 2006 Guidelines, Volume 3, Chapter 4.

#### 41.4. Emission Factors

When using the Tier 2 approach and the carbon content of the materials used is unknown, Table 4.21 in Volume 3, Chapter 4 of the IPCC 2006 Guidelines provides default emission factors. When using the Tier 3 approach the emission factor to be used is the carbon content (kg carbon/kg material) of the materials consumed.

Guidance on emission factors can be found in Section 4.6.2.2, Volume 3, Chapter of the IPCC 2006 Guidelines. Emission factors are also provided in Annexure C of this document.

## 42. Zinc Production

Zinc can be produced using one of three processes. The only process which does not produce emissions is the electrolytic process. All other primary and secondary production processes produce emissions and those companies which use these processes should use the guidance in this annexure to report their emissions. The methodology to determine the emissions associated with zinc production is detailed in Volume 3, Chapter 4 of the 2006 IPCC guidelines.

### 42.1. IPCC Classification

All direct emissions of a company should be reported. The emissions produced in the furnace, along with the emissions from the combustion of fuel used in the sintering, smelting and refining process, should be reported under the IPCC category of "2C6 Zinc Production".

The IPCC 2006 Guidelines give guidance on where the various emissions should be reported. This has been summarised specifically for zinc production companies in the table below. The methodology to determine the emissions associated with zinc production is detailed in Volume 3, Chapter 4 of the 2006 IPCC guidelines.

Table 42:1 IPCC Classification of emissions for Zinc Production

Sector	Relevant IPCC code/s	Definition	Relevant IPCC Gases	Tier	Methodology reference	Transitional arrangements
Zinc Production	1A2b	Fuel combustion activities from non-ferrous metals.	CO <sub>2</sub>	2 or 3	Section 12	Yes
			CH <sub>4</sub>	1, 2 or 3	Section 12	No
			N <sub>2</sub> O	1, 2 or 3	Section 12	No
	2C6	Zinc production	CO <sub>2</sub>	2 or 3	Section 42	Yes

Please note that the table above details the sectors that should be covered as a minimum. If there are other emission sources, under control of the data provider, that still need to be reported please report them under the relevant categories as listed in Table 5:2 of this document.

### 42.2. Methodology

#### Method 1: IPCC Tier 1 — Zinc production

CO<sub>2</sub> emissions from zinc production can essentially be estimated using the Tier 1 method, whereby:

$$E_{CO_2} = [Zn \cdot EF_{\text{default}}]$$

Where;

$E_{CO_2}$  = CO<sub>2</sub> emissions from zinc production, tonnes

Zn = quantity of zinc produced, tonnes

EF (default) = default emission factor, tonnes CO<sub>2</sub>/tonne zinc produced (2006 IPCC Guidelines Volume 3, Chapter 4, Table 4.24).

### **Method 2: IPCC Tier 2 — Zinc production**

The Tier 2 approach can be used when plant specific activity data is available including country-specific or plant-specific emission factors.

### **Method 3: IPCC Tier 3 — Zinc production**

The Tier 3 approach is the most accurate and makes use of continuous emissions monitoring (CEM). This is where the actual CO<sub>2</sub> emissions from the zinc facility are measured. When using the Tier 3 approach it is also possible, instead of using CEM, to multiply plant specific activity data by a plant-specific emission factor instead.

Please consult section 7.1 for guidance on direct CO<sub>2</sub> emissions measurement from industrial stacks.

#### **42.3. Activity data**

Guidance on the selection of activity data is provided in the IPCC 2006 Guidelines, please refer to section 4.7.2.3 of Volume 3, Chapter 4.

#### **42.4. Emission Factors**

Guidance on the selection of emission factors is provided in the IPCC 2006 Guidelines, please refer to section 4.7.2.2 of Volume 3, Chapter 4. These emission factors are also listed in Annexure C of this document.

## 43. Other

There are additional metal production processes that may occur where guidance has not been provided however GHGs may be released during the production process. This chapter will provide guidance on how to estimate emissions from these processes.

### 43.1. IPCC Classification

All direct emissions of a company should be reported under IPCC Category "2C7 Other".

Table 43:1 IPCC Classification of emissions for Other

Sector	Relevant IPCC code/s	Definition	Relevant IPCC Gases	Tier	Methodology reference	Transitional arrangements
Other	1A2b	Fuel combustion activities from non-ferrous metals.	CO <sub>2</sub>	2 or 3	Section 12	Yes
			CH <sub>4</sub>	1, 2 or 3	Section 12	No
			N <sub>2</sub> O	1, 2 or 3	Section 12	No
	2C7	Other	CO <sub>2</sub>	2 or 3	Section 43	No

Please note that the table above details the sectors that should be covered as a minimum. If there are other emission sources, under control of the data provider, that still need to be reported please report them under the relevant categories as listed in Table 5:2 of this document.

### 43.2. Methodology

Due to the lack of guidance on the category a Tier 2 or Tier 3 approach is advised to be undertaken when estimating emissions.

#### Method 2: IPCC Tier 2 methodology – Other

Method 2 sets out the estimation of emissions from a facility. It specifies that emissions should be estimated using a carbon mass balance approach for the facility as a whole and emissions are to be reported as process (IPPU) emissions. Method 2 utilises carbon content factors listed in Table 37:3 of this document. These carbon content factors are derived directly from the carbon dioxide emission factors listed in Volume 2, Chapter 1, Table 1.3 of the 2006 IPCC Guidelines.

The carbon mass balance approach requires fuels to be estimated based on quantities of fuels delivered rather than consumed. Stock figures should be used to convert "delivered" figures to "consumption" figures as explained further in the formulas provided under Chapter 37 above.

### Method 3: IPCC Tier 3 — Other

The Tier 3 methodology is similar to the Tier 2 methodology. The difference is that the Tier 3 methodology requires plant specific information on carbon content of all the input, products and by-products in the Iron and Steel Process. In the event of a tier 3 methodology being used for calculating GHG emissions from an iron and steel facility with coke making capacity, all emissions from the iron and steel process arising from the use of coal as a reducing agent fall within the IPPU (process) emission category.

#### 43.3. Activity data

Guidance on the selection of activity data is provided below in Table 43:2

**Table 43:2: Activity data required for emission estimation**

Tier 2 and 3	Other information
i) Quantity and details of different types of carbonates used in the production process ii) Calcination level achieved for each type of used carbonates	i) Implemented GHG emission abatement measures and estimates of abatement ii) Plant specific GHG emission factors iii) Amount of other carbonates, e.g. soda ash iv) Information on data quality and uncertainty estimates

## 44. Other Product and Manufacture Use

Sulphur hexafluoride (SF<sub>6</sub>) is used for electrical insulation and current interruption in equipment used in the transmission and distribution of electricity. Emissions occur at each phase of the equipment life cycle, including manufacturing, installation, use, servicing, and disposal. Most of the SF<sub>6</sub> used in electrical equipment is used in gas insulated switchgear and substations (GIS) and in gas circuit breakers (GCB), though some SF<sub>6</sub> is used in high voltage gas-insulated lines (GIL), outdoor gas-insulated instrument transformers and other equipment. The applications may be divided into two categories of containment.

The chapter provides guidance on estimating emissions of sulphur hexafluoride (SF<sub>6</sub>) from the manufacture and use of electrical equipment and several other products. Electrical equipment is the largest consumer and most important use of SF<sub>6</sub> globally.

### 44.1. IPCC Classification

Emissions of these GHGs can occur during the manufacture and use of electrical equipment. Emissions from this category depend on:

- The installed (banked) quantities of SF<sub>6</sub>
- The tightness of the equipment to prevent leakage
- Handling and maintenance processes
- Designing equipment to require a smaller charge of SF<sub>6</sub> and to be more leak tight
- Improving equipment handling and maintenance processes

Emissions of SF<sub>6</sub> from electrical equipment can be estimated in a variety of ways with varying degrees of complexity and data intensity. Data providers need to report the use of SF<sub>6</sub> and the emission estimates in the IPCC category 2G1 Electrical Equipment.

The minimum relevant emission categories to be reported for petrochemical and carbon black production facilities are presented in the table below:

Table 44:1 IPCC Classification of emissions from SF<sub>6</sub> emissions.

Sector	Relevant IPCC code/s	Definition	Relevant IPCC Gases	Tier	Methodology reference	Transitional arrangements
Other Product Manufacture and Use	1A1ai	Comprises emissions from all fuel use for electricity generation from	CO <sub>2</sub> <sup>32</sup>	2 or 3	Section 12	Yes
			CH <sub>4</sub>	1, 2 or 3	Section 12	No

<sup>32</sup> Note that CO<sub>2</sub> emissions from the use of biomass, biofuels and biogas for electricity generation should be reported but excluded from emission totals.

		main activity producers except those from combined heat and power plants.	N <sub>2</sub> O	1, 2 or 3	Section 12	No
	2G1	Electrical equipment is used in the transmission and distribution of electricity above 1 kV. SF <sub>6</sub> is used in gas-insulated switchgear (GIS), gas circuit breakers (GCB), gas-insulated transformers (GIT), gas-insulated lines (GIL), outdoor gas-insulated instrument transformers, reclosers, switches, ring main units and other equipment	SF <sub>6</sub>	1,2 or 3	Section 44	NA

Please note that the table above details the sectors that should be covered as a minimum. If there are other emission sources, under control of the data provider, that still need to be reported please report them under the relevant categories as listed in Table 5:2 of this document.

#### 44.2. Methodology

##### Method 1: IPCC Tier one – Default emission factor method

The Tier 1 method is the simplest approach for estimating SF<sub>6</sub> emissions from electrical equipment. Emissions are estimated by multiplying default emission factors by the SF<sub>6</sub> consumption of equipment manufacturers and/or by the nameplate SF<sub>6</sub> capacity of the equipment at each life cycle phase after manufacturing:

$$\text{Total emissions} = \text{Manufacturing emissions} + \text{Equipment installation emissions} \\ + \text{Equipment use emissions} + \text{Equipment disposal emissions}$$

Where:

Manufacturing emissions = Manufacturing emission factor x Total SF<sub>6</sub> consumption by equipment manufacturers

Equipment installation emissions = Installation emission factor x Total nameplate capacity of new equipment filled onsite (not at the factory)

Equipment use emissions = Use emission factor x Total nameplate of installed equipment (The "use emission factor" includes emissions due to leakages, servicing, and maintenance as well as failures.)

Equipment disposal emissions = Total nameplate capacity of retiring equipment x Fraction of SF<sub>6</sub> remaining at retirement

### **Method 2: IPCC Tier 2 – Equipment disposal emissions under country specific emission factor method**

The Tier 2 method uses the same basic equation as Tier 1 but requires reliable country-specific emission factors for each life cycle stage. Country-specific emission factors will be more accurate because they reflect the unique circumstances in which electrical equipment is used in each country. In addition, if detailed data for equipment retirement are available, emissions due to retirement can be estimated more accurately.

**Equipment disposal emissions = Total nameplate capacity of retiring equipment x Fraction of SF<sub>6</sub> remaining at retirement x (1 – fraction of retiring equipment whose SF<sub>6</sub> is recovered x recovery efficiency x fraction of recovered SF<sub>6</sub> recycled, reused with no further treatment, or destroyed)**

### **Method 3: IPCC Tier 3 - Life cycle approach**

The Tier 3 method is the most accurate approach for estimating emissions of SF<sub>6</sub> from electrical equipment. The method is implemented at the facility level and includes separate equations for each phase of the life cycle of the equipment, as discussed below.

**Equipment Manufacturing Emissions:** Emissions can be estimated using either a pure mass-balance approach or a mixture (hybrid) of a mass-balance approach for some processes and an emission-factor based approach for others. The pure mass-balance approach is preferred except where a substantial fraction of a manufacturer's emissions come from processes whose emission rates fall below the precision of the measurements required for the mass-balance approach.

#### **Mass Balance:**

**Equipment manufacturing emissions = Decrease in SF<sub>6</sub> inventory + Acquisitions of SF<sub>6</sub> + Disbursements of SF<sub>6</sub>**

**Hybrid approach:** This method first requires that manufacturers separate the gas flows associated with processes for which the mass-balance approach will be used from the gas flows associated with processes for which the emission-factor approach will be used.



**Equipment manufacturing emissions = (Decrease in SF<sub>6</sub> inventory + Acquisitions of SF<sub>6</sub> + Disbursements of SF<sub>6</sub>) + Σ Nameplate capacity of equipment undergoing each process x Emission factor for that process**

**Equipment Installation Emissions:** Equipment installation emissions may be estimated using either a mass-balance or an emission-factor approach.

**Mass Balance:**

**Equipment installation emissions = SF<sub>6</sub> used to fill equipment + Nameplate capacity of new equipment**

**Hybrid approach:** This method first requires that manufacturers separate the gas flows associated with processes for which the mass-balance approach will be used from the gas flows associated with processes for which the emission-factor approach will be used.

**Equipment installation emissions = (SF<sub>6</sub> used to fill equipment + Nameplate capacity of new equipment) + Nameplate capacity of new equipment filled on-site x Installation emission factor**

**Equipment Use Emissions:** Equipment use emissions may be estimated using either a mass-balance or an emission-factor approach.

**Mass Balance:**

**Equipment use emissions = SF<sub>6</sub> used to recharge closed pressure equipment at serving + SF<sub>6</sub> used to recovered pressure equipment at serving**

**Hybrid approach:** This method first requires that users separate the gas flows associated with equipment for which the mass-balance approach will be used from the gas flows associated with equipment for which the emission-factor approach will be used.

**Equipment use emissions = (SF<sub>6</sub> used to recharge closed pressure equipment at serving + SF<sub>6</sub> used to recovered pressure equipment at serving) + Σ Nameplate capacity of equipment installed x Use emission factor**

**Equipment Disposal and Final Use Emissions:** Equipment disposal and final use emissions may be estimated using either a pure mass-balance or a hybrid approach, based on country-specific circumstances. In both the pure mass-balance and hybrid approaches, emissions from closed-pressure equipment are estimated using a mass-balance equation.

**Mass balance:** In countries where the gas-collection infrastructure (including recovery equipment, technician training, and economic or legal incentives to recover) is not very well-developed or widely applied, it is good practice to use the pure mass-balance approach:

$$\text{Disposal and final use emissions} = \text{Emissions from closed pressure equipment} + \text{Emissions from sealed pressure equipment (MB)}$$

Where:

Emissions from closed pressure equipment = Nameplate capacity of retired closed pressure equipment – SF<sub>6</sub> recovered from retired closed pressure equipment

Emissions from sealed pressure equipment (MB) = Nameplate capacity of retired sealed pressure equipment – SF<sub>6</sub> recovered from retired sealed pressure equipment

**Hybrid approach:** In countries where the disposal of equipment is well controlled and understood (i.e., where an efficient gas collection infrastructure is in place) the hybrid approach may be used, as follows:

$$\text{Disposal and final use emissions} = \text{Emissions from closed pressure equipment} + \text{Emissions from sealed pressure equipment (EF)}$$

Where:

Emissions from closed pressure equipment = Nameplate capacity of retired closed pressure equipment – SF<sub>6</sub> recovered from retired closed pressure equipment

Emissions from sealed pressure equipment (EF) = (Nameplate capacity of retired sealed pressure systems) – (Nameplate capacity of retired sealed pressure systems x Use emission factor x Lifetime of equipment) x (1 – fraction of retiring equipment whose SF<sub>6</sub> is recovered x recovery efficiency)

**Emissions from SF<sub>6</sub> recycling and destruction:** Some SF<sub>6</sub> emissions occur after the chemical is recovered. These emissions include emissions associated with recycling of SF<sub>6</sub>, as well as emissions associated with the destruction of SF<sub>6</sub>. Recycling may occur in three places, the site of the equipment manufacturer or user, or at a recycling facility.

Emissions associated with the destruction of SF<sub>6</sub> depend on the destruction efficiency of the process and the quantity of SF<sub>6</sub> fed into the process. Emissions from recycling of SF<sub>6</sub> may be estimated using the following equation:

$$\text{Emissions from recycling} = \text{Recycling emission factor} \times \text{Quantity SF}_6 \text{ fed into recycling process}$$

Emissions from the destruction of SF<sub>6</sub> may be estimated using the following equation:

$$\text{Emissions from Destruction} = \text{Destruction emission factor} \times \text{Quantity SF}_6 \text{ fed into destruction process}$$

#### 44.3. Activity data

Guidance on the selection of activity data is provided according to the petrochemical product produced. Please refer to section 3.9.2.3 of Volume 3, Chapter 3 of the 2006 IPCC Guidelines.

Table 44:2: SF<sub>6</sub> activity data

Tier 1	Tier 2	Other information
i) SF <sub>6</sub> consumption by equipment manufacturers ii) Total nameplate capacity of new equipment filled on site iii) Total nameplate capacity of installed equipment. iv) Total nameplate capacity of retiring equipment v) Fraction of SF <sub>6</sub> remaining at retirement	i) Total nameplate capacity of retiring equipment ii) Fraction of SF <sub>6</sub> remaining at retirement iii) fraction of retiring equipment whose SF <sub>6</sub> is recovered iv) recovery efficiency v) fraction of recovered SF <sub>6</sub> recycled, reused with no further treatment, or destroyed.	i) SF <sub>6</sub> stored in containers at the beginning of the year ii) SF <sub>6</sub> stored in containers at the end of the year iii) SF <sub>6</sub> purchased from chemical producers or distributors in bulk iv) SF <sub>6</sub> returned by equipment users or distributors with or inside of equipment v) SF <sub>6</sub> returned to site after off-site recycling vi) SF <sub>6</sub> contained in new equipment delivered to customers vii) SF <sub>6</sub> delivered to equipment users in containers viii) SF <sub>6</sub> returned to suppliers ix) SF <sub>6</sub> sent off-site for recycling x) SF <sub>6</sub> destroyed xi) Nameplate capacity of equipment undergoing each process xii) SF used to fill equipment xiii) SF used to recharge closed pressure equipment at servicing xiv) SF recovered from closed pressure equipment at servicing xv) Quantity SF <sub>6</sub> fed into recycling process xvi) Quantity SF <sub>6</sub> fed into destruction process

#### 44.4. Emission Factors

Factors that influence emission rates include the design of the equipment (which varies depending on when and where the equipment was manufactured), SF<sub>6</sub> handling practices, availability of state-of-the-art handling equipment, SF<sub>6</sub> prices, and regulations (e.g., recovery requirements). Variation of any one of these can change emission rates over time

or among countries. Suggested default emission factors have been developed for some regions based on recent research.

Table 44:3: Default emission factors for SF<sub>6</sub> lifecycle (IPCC, 2006)

Phase/Region	Manufacturing (Fraction SF <sub>6</sub> Consumption by Manufacturers)	Use (Includes leakage, major failures/arc faults and maintenance losses)  (Fraction per Year of Nameplate Capacity of All Equipment Installed)	Disposal (Fraction Nameplate Capacity of Disposed Equipment)	
			Lifetime (years)	Fraction of charge remaining at retirement <sup>c</sup>
Europe <sup>a</sup>	0.085 <sup>b</sup>	0.026	>35	0.95
Japan <sup>d</sup>	0.29 <sup>b</sup>	0.007	Not reported	0.95
U.S. <sup>e</sup>	<sup>f</sup>	0.14 <sup>g</sup>	>35	<sup>h</sup>

<sup>a</sup> Source: 'Reductions of SF<sub>6</sub> Emissions from High and Medium Voltage Electrical Equipment in Europe,' Ecofys, June 2005.  
<sup>b</sup> Includes emissions from installation  
<sup>c</sup> This refers to the percentage of the original charge or nameplate capacity remaining in the equipment at end of life; it represents the fraction of the nameplate capacity emitted before the equipment is recycled or disposed.  
<sup>d</sup> Based on data reported by the Federation of Electric Power Companies (FEPC) and the Japan Electrical Manufacturers' Association (JEMA) (FEPC and JEMA, 2004). These organisations reported average emission factors that include emissions from all equipment types, including sealed pressure systems, closed pressure systems, and gas-insulated transformers.  
<sup>e</sup> From the U.S. Inventory of Greenhouse Gases and Sinks, 1990-2002. (U.S. EPA, 2004). Value is from 1999, first year for which representative country-specific data were available.  
<sup>f</sup> No country-specific value available.  
<sup>g</sup> Includes emissions from installation.  
<sup>h</sup> Disposal emissions are included in use emission factor in the US.

Note: The emission factors above reflect the practices and technologies in place in 1995, i.e., before mitigation measures were implemented. References per footnotes a and d show how these developed further upon successive implementation of various voluntary measures later on. Schwarz (2006) relates state-of-the-art emission factors to mitigation measures in Germany.

## 45. Pulp and Paper Industry

The pulp and paper industry acts both as a source and a sink of GHG emissions.

Pending finalisation of the methodology this section does not include guidance to estimate sequestration.

### 45.1. IPCC Classification

The table below details the relationship between direct emission sources and the corresponding IPCC source categories for reporting under the National GHG Reporting Regulations.

Table 45:1 IPCC classification of emissions for the pulp and paper industry

Sector	Relevant IPCC code/s	Definition	Relevant IPCC Gases	Tier	Methodology reference	Transitional arrangements
Pulp and Paper	1A1ai	Comprises emissions from all fuel use for electricity generation from main activity producers.	CO <sub>2</sub>	2 or 3	Section 12	Yes
			CH <sub>4</sub>	1, 2 or 3	Section 12	No
			N <sub>2</sub> O	1, 2 or 3	Section 12	No
	1A2d	Stationary fuel combustion activities from pulp, paper and print including those from combined heat and power plants	CO <sub>2</sub>	2 or 3	Section 12	Yes
			CH <sub>4</sub>	1, 2 or 3	Section 12	No
			N <sub>2</sub> O	1, 2 or 3	Section 12	No
	4A1	A managed solid waste disposal site must have controlled placement of waste (i.e. waste directed to specific deposition areas, a degree of control of scavenging and fires) and will include at least one of the following: cover material; mechanical compaction; or levelling of the waste. This category can be subdivided into aerobic and anaerobic.	CH <sub>4</sub>	1, 2 or 3	Section 46	Yes

Please note that the table above details the sectors that should be covered as a minimum. If there are other emission sources, under control of the data provider, that still need to be reported please report them under the relevant categories as listed in Section 5 of this document.

The schematic below explains the emissions process flow for the pulp and paper industry.

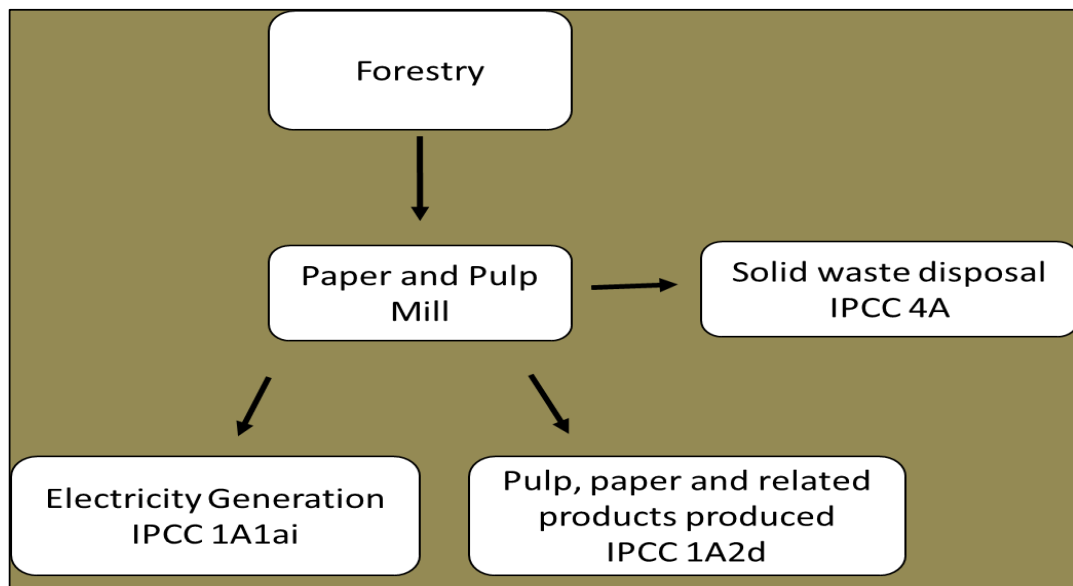

Figure 45:1: Process flow for pulp and paper industry.

#### 45.2. Methodology

There is no sector specific guidance on process emissions for the pulp and paper industry in the 2006 IPCC Guidelines. Please refer to the relevant sections of this guideline listed below for other emission sources from pulp and paper industry:

- Electricity generation and pulp, paper and related products produced – Section 12;
- Landfilling of bark and other organic waste – Section 40.

Sequestration should be calculated separately using the Methodological Guidelines for Quantification of Greenhouse Gas Emissions – Carbon Sequestration in the Forestry Industry.

#### 45.3. Activity Data

Activity data could include purchase receipts, delivery receipts or production reports.

#### 45.4. Emission Factors

For default IPCC emission factors please refer to Annexure A and for South African specific calorific values please refer to Annexure C of this document.

## 46. Solid Waste Disposal (industrial sites)

The treatment and subsequent disposal of solid waste originating from municipal or industrial sources produce methane (CH<sub>4</sub>). Solid waste disposal sites (SWDSs) also produce emissions that include non-methane volatile organic compounds (NMVOCs), biogenic carbon dioxide (CO<sub>2</sub>) and smaller quantities of carbon monoxide (CO), nitrous oxide (N<sub>2</sub>O) and nitrogen oxides (NO<sub>x</sub>). However, of these emissions only CH<sub>4</sub> emissions are required for reporting.

### 46.1. IPCC Classification

In the table below, direct emission sources are correlated to the respective IPCC reporting categories as relevant for the GHG Reporting Regulations.

Table 46:1 IPCC classification for Solid Waste

Sector	Relevant IPCC code/s	Definition	Relevant IPCC Gases	Tier	Methodology reference	Transitional arrangements
Solid Waste	1A1ai	Comprises emissions from all fuel use for electricity generation from main activity producers.	CO <sub>2</sub>	2 or 3	Section 12	Yes
			CH <sub>4</sub>	1, 2 or 3	Section 12	No
			N <sub>2</sub> O	1, 2 or 3	Section 12	No
	4A1	A managed solid waste disposal site must have controlled placement of waste (i.e. waste directed to specific deposition areas, a degree of control of scavenging and fires) and will include at least one of the following: cover material; mechanical compaction; or levelling of the waste. This category can be subdivided into aerobic and anaerobic.	CH <sub>4</sub>	2 or 3	Section 46	Yes

Please note that the table above details the sectors that should be covered as a minimum. If there are other emission sources, under control of the data provider, that still need to be reported please report them under the relevant categories as listed in Section 5 of this document.

### 46.2. Methodology

The IPCC methodology for estimating CH<sub>4</sub> emissions from SWDS is based on the First Order Decay (FOD) method. It is important to note that the methodology assumes that the degradable

organic carbon (DOC) in the waste at the SWDSs degrades over an extended period of a few decades, during which the CH<sub>4</sub> emissions are generated.

The CH<sub>4</sub> emissions can be calculated in accordance with the 2006 IPCC Guidelines Volume 6, Chapter 3, in Section 3.2.1. A brief overview of the available Tiered methodological options for emissions estimations and important aspects which require consideration are discussed below:

#### **Method 1: IPCC Tier 1 — Solid Waste Disposal**

The Tier 1 method applies default values for the emission factor and activity parameters and is considered good practice if there is limited data available.

To accurately calculate emissions from solid waste, it is suggested that the IPCC Waste Model is used. The tool can be downloaded from the IPCC website: <http://www.ipcc-nggip.iges.or.jp/public/2006gl/vol5.html>. This tool was created for country SWDS emission estimations and thus for the calculation of company specific SWDS emissions certain aspects should be taken into consideration:

- The tool requests that a data provider enters the amount of solid waste in Gigagrams disposed directly in a landfill site directly (industrial sites) or population and waste per capita in case of municipal landfill sites.

The tool provides results in Gigagrams (1 Gigagrams is equivalent to 1000 tonnes). As a result, the final answer can come out at zero. Therefore, the final result needs to be converted from Gigagrams to tonnes by multiplying by 1000

#### **Method 2: IPCC Tier 2 — Solid Waste Disposal**

The Tier 2 method is similar to Tier 1 except it allows for incorporation of country specific emission factors and country specific activity data.

#### **Method 3: IPCC Tier 3 — Solid Waste Disposal**

The Tier 3 method is a country specific method based on site specific data.

### **46.3. Activity Data**

For detailed guidance on choice of activity data please refer to section 3.2.2 in Volume 5, Chapter 3 of the 2006 IPCC Guidelines.

### **46.4. Emission Factors**

For detailed guidance on choice of emission factors please refer to section 3.2.3 in Volume 5 Chapter 3 of the 2006 IPCC Guidelines.



An important aspect that requires mention is the methane correction factor (MCF) as this factor greatly influences the estimated emissions. The MCF is influenced by the type of SWDS. Information relating to the types of SWDS and the MCF is presented in Table 40.2.

**Table 46:2: Type of Solid Waste Disposal Site and methane correction factors (MCF)**

Type of Site	Comment	Methane Correction Factor
<b>Managed - anaerobic</b>	These must have controlled placement of waste and include at least one of the following: (i) cover material; (ii) mechanical compacting; or (iii) levelling of the waste.	1.0
<b>Managed – semi-aerobic</b>	These must have controlled placement of waste and include all of the following structures for introducing air to waste layer: (i) permeable cover material; (ii) leachate drainage system; (iii) regulating pondage; and (iv) gas ventilation system.	0.5
<b>Unmanaged – deep (&gt;5m waste) and/or high water table</b>	All SWDS not meeting the criteria of managed SWDS and which have depths of greater than or equal to 5 metres and/or high water table at near ground level.	0.8
<b>Unmanaged – shallow(&lt;5m waste)</b>	All SWDS not meeting the criteria of managed SWDS and which have depths of less than 5 metres.	0.4
<b>Uncategorised SWDS</b>	Only if companies cannot categorise their SWDS into above four categories of managed and unmanaged SWDS, the MCF for this category can be used.	0.6

## 47. Industrial Wastewater Treatment

Treatment or disposal of wastewater through anaerobic digestion can result in a source of methane (CH<sub>4</sub>) being released. It can also be a source of nitrous oxide (N<sub>2</sub>O) emissions. Carbon dioxide (CO<sub>2</sub>) emissions from wastewater are not considered in the IPCC Guidelines because these are of biogenic origin and should not be included in national total emissions. This sector refers to wastewater that originates from commercial and industrial sources and which is treated on site.

Industries that must report in terms of this guidance are as listed below:<sup>33</sup>

- dairy products
- pulp, paper and paperboard
- meat and poultry
- organic chemicals
- raw sugar
- beer
- wine and other alcoholic beverages
- fruit and vegetables

### 47.1. IPCC Classification

In the table below, direct emission sources are correlated to the respective IPCC reporting categories as relevant for the GHG Reporting Regulations.

Table 47:1: IPCC classification for industrial wastewater treatment

Sector	Relevant IPCC code/s	Definition	Relevant IPCC Gases	Tier	Methodology reference	Transitional arrangements
Industrial Wastewater	1A1aii	Emissions from production of both heat and electrical power from main activity producers for sale to the public at a single CHP facility.	CO <sub>2</sub>	2 or 3	Section 12	Yes
			CH <sub>4</sub>	1, 2 or 3	Section 12	No
			N <sub>2</sub> O	1, 2 or 3	Section 12	No

<sup>33</sup> Industrial companies that have on-site sewage treatment plants must apply the IPCC methodology in section 4.D.1 of Volume 5 Chapter 4 of the 2006 IPCC Guidelines. In such cases, industries must apply biochemical oxygen demand (BOD), a measure of biodegradable organic matter, instead of chemical oxygen demand (COD).

Sector	Relevant IPCC code/s	Definition	Relevant IPCC Gases	Tier	Methodology reference	Transitional arrangements
Industrial Wastewater	4D2	Treatment and discharge of liquid wastes and sludge from industrial processes such as: food processing, textiles, or pulp and paper production. This includes anaerobic lagoons, anaerobic reactors, and discharge into surface waters.	CH <sub>4</sub> N <sub>2</sub> O	1, 2 or 3	Section 47	No

Please note that the table above details the sectors that should be covered as a minimum. If there are other emission sources, under control of the data provider, that still need to be reported please report them under the relevant categories as listed in table 5.2 of this document.

## 47.2. Methodology<sup>34</sup>

### Methane emissions from industrial wastewater treatment

The methane potential from industrial wastewater streams is based on the concentration of degradable organic matter in the wastewater, the volume of wastewater, and the technology employed to treat the wastewater streams.

The methane emissions can be calculated in accordance with 2006 IPCC Volume 5, Chapter 6 Wastewater treatment and discharge.

There are two possible methods of treatment for wastewater, namely: anaerobic digestion or aerobic digestion. If the wastewater plant is a well-managed aerobic treatment plant, then the emissions associated with the treatment process are zero and no further calculation is required

If a wastewater plant is not well managed, or is overloaded, or if the treatment plant is anaerobic, then the emissions from the treatment of wastewater can be estimated if the following three parameters are known or chosen

- chemical oxygen demand of the wastewater
- total wastewater volume treated
- methane correction factor for the type of treatment and discharge pathway (according to the table below)

<sup>34</sup> If CH<sub>4</sub> generated is flared for energy purposes, CO<sub>2</sub> generated needs to be reported under IPCC source 1A1 in the energy sector.

$$\text{Total CH}_4 \text{ emissions from wastewater} = \sum_f \left[ (W_f \times \text{COD}_f) \times \left( 0.25 \frac{\text{kg CH}_4}{\text{kg COD}} \times \text{MCF} \right) \right]$$

$W_f$  = Wastewater generated (m<sup>3</sup> per year)

$\text{COD}_f$  = Chemical oxygen demand (kg COD per m<sup>3</sup>)

MCF = methane correction factor

f = number of facilities

The methane correction factor (MCF) can be sourced from table Table 47:2:

Table 47:2: Type of treatment and discharge pathway with corresponding methane correction factor (MCF)

Type of Treatment and Discharge Pathway or System	Comment	Methane Correction Factor
Untreated and discharged to sea, river or lake	Rivers with high organics loadings may turn anaerobic, however this is not considered here.	0.1
Aerobic treatment plant	Must be well managed. Some methane can be emitted from settling basins and other pockets.	0
Aerobic treatment plant	Not well managed. Overloaded	0.3
Anaerobic digester or reactor	Methane recovery not considered	0.8
Anaerobic shallow lagoon	Depth less than 2 metres	0.2
Anaerobic deep lagoon	Depth more than 2 metres	0.8

Further refinement of the methane estimations from industrial waste water treatment can be done in accordance with the calculations in 2006 IPCC Volume 5, Chapter 6 Waste water treatment and discharge, these could include

- deduction of the organic fraction of the sludge if it is removed
- deduction of any recovered methane from the total
- expert calculations of the actual methane correction factor

### Nitrous Oxide emissions from industrial wastewater treatment and discharged treated water

Nitrous oxide emissions from industrial WWTPs, from wastewater after disposal of untreated wastewater and from wastewater treatment effluent into aquatic environments must be estimated for Industrial Wastewater Treatment.

To estimate N<sub>2</sub>O emissions from industrial wastewater treatment plants the following equation, from Vol 5 Ch 6 of the 2019 IPCC Refinements, is used:

$$N_2O_{plants\_IND} = \left[ \sum_i (T_{i,j} * EF_{plants,j} * TN_{IND,i}) \right] * \frac{44}{28}$$

$N_2O_{plants\_IND}$

=  $N_2O$  emissions from industrial wastewater treatment plants in reporting period (kg  $N_2O$ /yr)

$T_{i,j}$  = degree of utilisation of treatment system j for each industry i in the reporting period

$EF_j$  = emission factor for treatment system (kg  $N_2O - N$ /kg N)

$TN_{IND,i}$  = total nitrogen in wastewater from industry in reporting period (kg N/yr)

44/28 = conversion of kg  $N_2O - N$  into kg  $N_2O$

Where  $TN_{IND,i}$  is calculated as follows:

$$TN_{IND,i} = P_i * W_i * TN_i$$

$TN_{IND,i}$  = total nitrogen in wastewater from industry in reporting period (kg N/yr)

i = industrial sector

$P_i$  = total industrial product for industrial sector i (t/yr)

$W_i$  = wastewater generated for industrial sector i ( $m^3/t_{product}$ )

$TN_{IND,i}$  = total nitrogen in wastewater entering for industry i (kg TN/yr)

Default values for wastewater generated and total nitrogen for industrial sectors are shown in Table 47:3 below.

Table 47:3: Default Industrial Wastewater Data (Table 6.12, 2019 IPCC Refinement)

Industry Type	Default IPCC parameters			
	Wastewater Generation W ( $m^3/t$ )	Range for W	Total Nitrogen TN ( $kg/m^3$ )	TN Range ( $kg/m^3$ )
Alcohol refining	24	16–22	2.4	0.94-3.86
Beer and Malt	6.3	5–9	0.055	0.025-0.08
Fish processing	5	2-8	0.6	0.21-0.98
Iron & Steel	5	0.004-10.4	0.25	0.0004-0.524
Meat & Poultry	13	8–18	0.19	0.17-0.2
Nitrogen fertiliser	2.89	0.46-8.3	0.5	0.1-0.8
Plastics & resins	0.6	0.3-1.2	0.25	Not provided
Starch production	9	4-18	0.9	0.8-1.1

To estimate  $N_2O$  emissions from industrial wastewater effluent the following equation, from Vol 5 Ch 6 of the 2019 IPCC Refinements, is used:

$$N_2O_{effluent\_IND} = N_{effluent\_IND} * EF_{effluent} * 44/28$$

$N_2O_{effluent\_IND}$  =  $N_2O$  emissions from industrial wastewater effluent in reporting period (kg  $N_2O$ /yr)

$N_{effluent\_IND}$  = nitrogen in industrial wastewater effluent (kg N/yr)

$EF_{effluent}$  = emission factor for  $N_2O$  emissions from industrial wastewater effluent (kg  $N_2O - N$ /kg N)

44/28 = conversion of kg N<sub>2</sub>O – N into kg N<sub>2</sub>O

Where N<sub>effluent\_IND</sub> is calculated as follows:

$$N_{effluent\_IND} = \sum_j [TN_{IND,i} * T_j * (1 - N_{REM,j})]$$

N<sub>effluent\_IND</sub> = nitrogen in industrial wastewater effluent (kg N/yr)

TN<sub>IND,i</sub> = total nitrogen in wastewater from industry in reporting period (kg N/yr)

T<sub>j</sub> = degree of utilisation of treatment system j in the reporting period

N<sub>REM</sub>

= fraction of total wastewater nitrogen removed during wastewater treatment per treatment type

The fractions of total wastewater nitrogen removed during wastewater treatment (N<sub>REM</sub>) can be sourced from Table 47:4

**Table 47:4: Wastewater treatment nitrogen removal fractions (N<sub>REM</sub>) according to treatment type (Table 6.10c, 2019 IPCC Refinements)**

Treatment Type	N <sub>REM</sub>	Range
No treatment	0	0
Primary (mechanical)	0.1	0.05-0.2
Secondary (biological)	0.4	0.35-0.55
Tertiary (advanced biological)	0.8	0.45-0.85
Septic tank	0.15	0.1-0.25
Septic tank + land dispersal field	0.68	0.62-0.73
Latrine	0.12	0.07-0.21

### 47.3. Activity Data

The following activity data needs to be monitored per wastewater facility:

- wastewater generated (m<sup>3</sup> per year)
- chemical oxygen demand (kg COD per m<sup>3</sup>)

**Table 47:5:** Default IPCC activity data that could be used to quantify GHG emissions if plant-specific data is not available (Doorn et al, 1997)

Industry Type	Default IPCC parameters			
	Wastewater Generation (m <sup>3</sup> /t)	Range for W	COD (kg/m <sup>3</sup> )	COD Range (kg/m <sup>3</sup> )
Alcohol refining	24	16–22	11	5–22
Beer and Malt	6.3	5–9	2.9	2–7
Coffee	Not available	Not available	9	3–15
Dairy products	7	3–10	2.7	15–52
Fish processing	Not available	8–18	2.5	Not available
Meat & Poultry	13	8–18	4.1	2–7

Industry Type	Default IPCC parameters			
	Wastewater Generation (m <sup>3</sup> /t)	Range for W	COD (kg/m <sup>3</sup> )	COD Range (kg/m <sup>3</sup> )
Organic chemicals	67	0–400	3	0.8–5
Petroleum refineries	0.6	0.3–1.2	1	0.4–1.6

#### 47.4. Emission Factors

The CH<sub>4</sub> emission factor is determined by multiplying the methane correction factor by 0.25 in the equation described above.

The N<sub>2</sub>O emissions factors for both industrial wastewater treatment and discharged treated water are shown below.

Table 47:6: Default N<sub>2</sub>O emission factor values for industrial wastewater (Table 6.8A, 2019 IPCC Refinement)

Type of Treatment System	Comment	Emission Factor (kg N <sub>2</sub> O-N/kg N)	Range
<b>Discharge from treated or untreated system, EF<sub>effluent</sub></b>			
Freshwater, estuarine & marine discharge (Tier 1)	Based on limited field data and on specific assumptions regarding the occurrence of nitrification and denitrification in rivers and in estuaries	0.005	0.0005-0.075
Nutrient-impacted and/or hypoxic freshwater, estuarine, & marine environments (Tier 3, if needed)	Higher emissions are associated with nutrient-impacted/hypoxic water such as eutrophic lakes, estuaries and rivers, or locations where stagnant conditions occur.	0.019	0.0041-0.091
<b>Wastewater treatment system, EF<sub>plants</sub></b>			
Centralised, aerobic treatment plant	N <sub>2</sub> O variable and can be significant	0.016	0.00016-0.045
Anaerobic reactor	N <sub>2</sub> O is not significant	0	0-0.001
Anaerobic lagoons	N <sub>2</sub> O is not significant	0	0-0.001
Septic tank	N <sub>2</sub> O is not significant	0	0-0.001
Septic tank + land dispersal field	N <sub>2</sub> O is emitted by the soil dispersal system	0.0045	
Latrine	N <sub>2</sub> O is not significant	0	0-0.001
<b>Sludge treatment system</b>			
Anaerobic digester for sludge	N <sub>2</sub> O is not significant	0	0

## 48. Domestic Wastewater Treatment

Treatment or disposal of wastewater through anaerobic digestion can result in a source of methane (CH<sub>4</sub>) being released. It can also be a source of nitrous oxide (N<sub>2</sub>O) emissions. Carbon dioxide (CO<sub>2</sub>) emissions from wastewater are not considered in the IPCC Guidelines because these are of biogenic origin and should not be included in national total emissions. This sector refers to wastewater that originates from domestic sources.

### 48.1. IPCC Classification

In the table below, direct emission sources are correlated to the respective IPCC reporting categories as relevant for the GHG Reporting Regulations.

Table 48:1: IPCC classification for domestic wastewater treatment

Sector	Relevant IPCC code/s	Definition	Relevant IPCC Gases	Tier	Methodology reference	Transitional arrangements
Domestic Wastewater	1A1aii	Emissions from production of both heat and electrical power from main activity producers for sale to the public at a single CHP facility.	CO <sub>2</sub>	2 or 3	Section 12	Yes
			CH <sub>4</sub>	1, 2 or 3	Section 12	No
			N <sub>2</sub> O	1, 2 or 3	Section 12	No
	4D1	Treatment and discharge of liquid wastes and sludge from housing and commercial sources (including human waste) through: wastewater sewage systems collection and treatment systems, open pits / latrines, anaerobic lagoons, anaerobic reactors and discharge into surface waters.	CH <sub>4</sub> N <sub>2</sub> O	1, 2 or 3	Section 48	No

Please note that the table above details the sectors that should be covered as a minimum. If there are other emission sources, under control of the data provider, that still need to be reported please report them under the relevant categories as listed in Section 5 of this document.



## 48.2. Methodology<sup>35</sup>

### Methane emissions from domestic wastewater treatment and discharged treated water

The methane potential from domestic wastewater streams is based on the concentration of degradable organic matter in the domestic wastewater, the population of the community, and the type of treatment system.

The methane emissions can be calculated in accordance with 2006 IPCC Volume 5, Chapter 6 Wastewater treatment and discharge.

If the domestic wastewater plant is a well-managed aerobic treatment plant, then the emissions associated with the treatment process are zero and no further calculation is required. If a domestic wastewater plant is not well managed, or is overloaded, or if the treatment plant is anaerobic, then the emissions from the treatment of domestic wastewater can be estimated if the following three parameters are known or chosen:

- biochemical oxygen demand of the domestic wastewater
- total domestic wastewater volume treated
- methane correction factor for the type of treatment and discharge pathway (according to the table below)

$$\text{CH}_4_{\text{domestic wastewater treatment}} = \left[ \sum_{i,j} U_i * T_{i,j} * 0.6 * MCF \right] * [(P * BOD * 0.001 * I * 365) - S] - R$$

$U_i$  = fraction of population in income group  $i$  in the community<sup>36</sup>

$T_{i,j}$   
= degree of utilisation of  $\frac{\text{treatment}}{\text{discharge}}$  pathway system  $j$  for each incomegroup fraction  $i$  in the community<sup>37</sup>

0.6 = the default maximum  $\text{CH}_4$  producing capacity ( $B_o$ , kg  $\text{CH}_4/\text{kg BOD}$ ) for domestic water

MCF = methane correction factor

P = community population in reporting period (person)

BOD = biochemical oxygen demand (g/person/day)<sup>38</sup>

0.001 = conversion of grams BOD to kg BOD

I = correction factor for additional industrial BOD discharged into sewers<sup>39</sup>

S = organic component removed as sludge in reporting period (kg BOD/yr)

R = amount of  $\text{CH}_4$  recovered in the inventory year (kg  $\text{CH}_4/\text{yr}$ )

<sup>35</sup> If  $\text{CH}_4$  generated is flared for energy purposes,  $\text{CO}_2$  generated needs to be reported under IPCC source 1A1 in the energy sector.

<sup>36</sup> The sum of U should equal 1 for each community. Hence if the entire community served by the treatment plant is the same income group then the value of U should equal 1.

<sup>37</sup> The sum of T should equal 1 for each community. Hence if only one treatment/discharge pathway or system is used T should equal 1.

<sup>38</sup> Default BOD for Africa is 37 g/person/day

<sup>39</sup> For collected use 1.25, for uncollected use 1

The methane correction factor (MCF) for domestic wastewater treatment can be sourced from Table 48:2.

Table 48:2: Type of treatment system with corresponding methane correction factor (MCF) (Table 6.3, 2006 IPCC Guidelines)

Type of Treatment System	Comment	Methane Correction Factor
<b>Wastewater Treatment System</b>		
Centralised, aerobic treatment plant	Must be well managed. Some CH <sub>4</sub> can be emitted from settling basins and other pockets.	0
Centralised, aerobic treatment plant	Not well managed. Overloaded.	0.3
Anaerobic digester for sludge	CH <sub>4</sub> recovery is not considered here.	0.8
Anaerobic reactor	CH <sub>4</sub> recovery is not considered here.	0.8
Anaerobic shallow lagoon	Depth less than 2 meters	0.2
Anaerobic deep lagoon	Depth more than 2 meters	0.8
Septic system	Half od BOD settles in anaerobic tank	0.5
Latrine	Dry climate, ground water table lower than latrine, small family (3-5 persons)	0.1
Latrine	Dry climate, ground water table lower than latrine, communal (many users)	0.5
Latrine	Wet climate/flush water use, ground water table higher than latrine	0.7
Latrine	Regular sediment removal for fertiliser	0.1

Further emissions need to be estimated and reported for discharges of treated water using the equation below.

$$CH_4_{effluent} = \left[ \sum_{i,j} U_i * T_{i,j} * 0.6 * MCF \right] * \{ [P * BOD * 0.001 * I * 365 * T_j * (1 - TOW_{REM,j})] - S \} - R$$

U<sub>i</sub> = fraction of population in income group *i* in the community<sup>40</sup>

<sup>40</sup> The sum of U should equal 1 for each community. Hence if the entire community served by the treatment plant is the same income group then the value of U should equal 1.

- $T_{i,j}$  = degree of utilisation of treatment  
/discharge pathway system  $j$  for each group fraction  $i$  in the community<sup>41</sup>
- 0.6 = the default maximum CH<sub>4</sub> producing capacity ( $B_o$ , kg CH<sub>4</sub>/kg BOD) for domestic water
- MCF = methane correction factor
- P = community population in reporting period (person)
- BOD = biochemical oxygen demand (g/person/day)<sup>42</sup>
- 0.001 = conversion of grams BOD to kg BOD
- I = correction factor for additional industrial BOD discharged into sewers<sup>43</sup>
- $TOW_{REM,j}$   
= fraction of total wastewater organics removed during wastewater treatment per treatment type  $j$
- S = organic component removed as sludge in reporting period (kg BOD/yr)
- R = amount of CH<sub>4</sub> recovered in the inventory year (kg CH<sub>4</sub>/yr)

The methane correction factor (MCF) for discharged treated water can be sourced from Table 48:3 below.

**Table 48:3: Type of discharge pathway with corresponding methane correction factor (MCF) (Table 6.3, 2019 IPCC Refinements)**

Type of Discharge Pathway	Comment	Methane Correction Factor
<b>Discharge from treated or untreated systems</b>		
Discharge to aquatic environments (Tier 1)	Most aquatic environments including rivers are supersaturated in CH <sub>4</sub> . Nutrient oversupply will increase CH <sub>4</sub> emissions. Environments where carbon accumulates in sediments have higher potential for methane generation.	0.11
Discharge to aquatic environments other than reservoirs, lakes and estuaries (Tier 2)	Most aquatic environments including rivers are supersaturated in CH <sub>4</sub> . Nutrient oversupply will increase CH <sub>4</sub> emissions.	0.035
Discharge to reservoirs, lakes and estuaries (Tier 2)	Environments where carbon accumulates in sediments have higher potential for methane generation.	0.19
Stagnant sewer	Open and warm	0.5
Flowing sewer (open or closed)	Fast moving, clean. (Insignificant amounts of CH <sub>4</sub> from pump stations, etc)	0

The fractions of total wastewater organics removed during wastewater treatment ( $TOW_{REM}$ ) can be sourced from Table 48:4.

<sup>41</sup> The sum of T should equal 1 for each community. Hence if only one treatment/discharge pathway or system is used T should equal 1.

<sup>42</sup> Default BOD for Africa is 37 g/person/day

<sup>43</sup> For collected use 1.25, for uncollected use 1

Table 48:4: Wastewater treatment organics removal fractions ( $TOW_{REM}$ ) according to treatment type (Table 6.6B, 2019 IPCC Refinements)

Treatment Type	$TOW_{REM}$
Untreated systems	0
Primary (mechanical treatment plants)	0.4
Primary + Secondary (biological treatment plants)	0.85
Primary + Secondary + Tertiary (advanced biological treatment plants)	0.9
Septic tank/septic system	0.625
Latrines – Dry climate, groundwater table lower than latrines, small family (3-5 persons)	0.1
Latrines – Dry climate, groundwater table lower than latrines, communal (many users)	0.5
Latrines – Wet climate/flush water use, groundwater table higher than latrine	0.7

### Nitrous Oxide emissions from domestic wastewater treatment and discharged treated water

Nitrous oxide emissions from domestic wastewater treatment are emitted as direct emissions from treatment plants or as indirect emissions from disposed wastewater into waterways, lakes or the sea. Typically, the direct emissions from the wastewater treatment plant are much less than the indirect emissions from wastewater treatment effluent that is discharged into aquatic environments.

To estimate indirect  $N_2O$  emissions from wastewater effluent the following equation, from Vol 5 Ch 6 of the 2006 IPCC Guidelines, is used:

$$N_2O_{\text{emissions from wastewater effluent}} = N_{\text{effluent}} * EF_{\text{effluent}} * 44/28$$

- $N_2O_{\text{emissions from wastewater effluent}}$  =  $N_2O$  emissions in reporting period (kg  $N_2O$ /yr)
- $N_{\text{effluent}}$  = nitrogen in the effluent discharged to aquatic environments (kg N/yr)
- $EF_{\text{effluent}}$  = emission factor for  $N_2O$  emissions from discharged to wastewater (kg  $N_2O$ / kg N)
- 44/28 = conversion of kg  $N_2O - N$  into kg  $N_2O$

Where  $N_{\text{effluent}}$  is estimated, as per Vol 5 Ch 6 of the 2006 IPCC Guidelines, as follows:

$$N_{\text{effluent}} = (P * Protein * F_{NPR} * F_{NON-CON} * F_{IND-COM}) - N_{\text{sludge}}$$

- $N_{\text{effluent}}$  = nitrogen in the effluent discharged to aquatic environments (kg N/yr)
- P = population served by the treatment plant
- Protein = annual per capita protein consumption (kg/person/yr)<sup>44</sup>
- $F_{NPR}$  = fraction of nitrogen in protein (kg N/kg protein)<sup>45</sup>

<sup>44</sup> Use national statistics, literature sources or the FAOSTAT Food Balance Sheets

<sup>45</sup> Default value for  $F_{NPR}$  is 0.16 kg N/kg protein

$F_{\text{NON-COM}}$  = factor for non – consumed protein added to the wastewater<sup>46</sup>

$F_{\text{IND-COM}}$  = factor for industrial and commercial co  
– discharged protein into the sewere system<sup>47</sup>

$N_{\text{sludge}}$  = nitrogen removed with sludge (kg N/yr)<sup>48</sup>

To estimate direct  $N_2O$  emissions from centralised wastewater treatment processes the following equation, from Vol 5 Ch 6 of the 2006 IPCC Guidelines, is used:

$$N_2O_{\text{plants}} = P * T_{\text{plant}} * F_{\text{IND-COM}} * EF_{\text{plant}}$$

$N_2O_{\text{plants}}$  =  $N_2O$  emissions from plants in the reporting period (kg  $N_2O$ /yr)

P = population served by the treatment plant

$T_{\text{plant}}$  = degree of utilisation of modern, centralised WWT plant (%)

$F_{\text{IND-COM}}$  = factor for industrial and commercial co  
– discharged protein into the sewere system<sup>49</sup>

$EF_{\text{plant}}$  = emission factor for  $N_2O$  emissions from wastewater treatment (g  $N_2O$ /person /year)

It should be noted that when  $N_2O$  emissions from plants are estimated, the amount of nitrogen associated with the emissions must be calculated (i.e.  $N_2O_{\text{plants}} * 28/44$ ) and subtracted from the  $N_{\text{effluent}}$  value that will be used to determine  $N_2O$  emissions from wastewater effluent.

### 48.3. Activity Data

The following activity data needs to be monitored per domestic wastewater treatment facility:

- Population of the community/communities served
- Income demographics of the community/communities served
- Degree of utilisation of treatment/ discharge pathway or system

### 48.4. Emission Factors

The  $CH_4$  emission factors, for both domestic wastewater treatment and discharged treated water, is determined by multiplying the methane correction factor by 0.6 ( $B_0$ ) in the equation described above.

The  $N_2O$  emissions factors for both domestic wastewater treatment and discharged treated water are shown below.

<sup>46</sup> Default value for  $F_{\text{NON-COM}}$  is 1.1 for countries without garbage disposals and 1.4 for countries with garbage disposals

<sup>47</sup>  $F_{\text{IND-COM}}$  is considered because wastewater from industrial or commercial sources that are discharged into the sewer may contain protein. The default value for  $F_{\text{IND-COM}}$  is 1.25

<sup>48</sup> Default value for  $N_{\text{sludge}}$  is 0 kg N/yr

<sup>49</sup>  $F_{\text{IND-COM}}$  is considered because wastewater from industrial or commercial sources that are discharged into the sewer may contain protein. The default value for  $F_{\text{IND-COM}}$  is 1.25

Table 48:5: N<sub>2</sub>O Emission Factors for domestic wastewater (Table 6.11, 2006 IPCC Guidelines)

N <sub>2</sub> O Emission Factor	Default
EF <sub>effluent</sub>	0.005 kg N <sub>2</sub> O-N/kg-N
EF <sub>plants</sub>	3.2 g N <sub>2</sub> O/person/year

## 49. Waste Incineration

Two combustion processes, incineration in combustion chambers and open burning of waste are considered in this section.

The open burning of waste is defined as a combustion process that is carried out in an open-air environment, where smoke and other emissions that are released during combustion, are released directly into the atmosphere. Open combustion may also include incineration devices which do not provide sufficient residence time for complete combustion of the waste (resulting from inadequate temperature control and insufficient air flow among other factors).

Emissions associated with waste incineration and open burning are CO<sub>2</sub>, N<sub>2</sub>O and CH<sub>4</sub>. The most significant among these three emissions are CO<sub>2</sub> and this would be the only gas that would require reporting.

### 49.1. IPCC Classification

In the table below, direct emission sources are correlated to the respective IPCC reporting categories as relevant for the GHG Reporting Regulations. The methodology to determine the emissions associated with waste incineration is detailed in Volume 5, Chapter 5 of the 2006 IPCC Guidelines.

Table 49:1: IPCC classification for Solid Waste

Sector	Relevant IPCC code/s	Definition	Relevant IPCC Gases	Tier	Methodology reference	Transitional arrangements
Waste Incineration	1A1aii	Emissions from production of both heat and electrical power from main activity producers.	CO <sub>2</sub> (fossil fraction)	2 or 3	Section 12	Yes
			CH <sub>4</sub>	1, 2 or 3	Section 12	No
			N <sub>2</sub> O	1, 2 or 3	Section 12	No
	4C1	Combustion of solid wastes in controlled incineration facilities.	CO <sub>2</sub>	1, 2 or 3	Section 49	No
			CH <sub>4</sub>	1, 2 or 3	Section 49	No

Please note that the table above details the sectors that should be covered as a minimum. If there are other emission sources, under control of the data provider, that still need to be reported please report them under the relevant categories as listed in table 5.2 of this document.

## 49.2. Methodology

The IPCC methodology for estimating emissions depends on the nature of the combustion process used to incinerate the waste and the type of waste incinerated.

### Carbon dioxide emissions

#### Method 1: IPCC Tier 1 — Waste Incineration – CO<sub>2</sub>

The Tier 1 method of estimating emissions is based on waste quantities and default emission factors. The calculation of CO<sub>2</sub> emissions from waste incineration is based on an estimate of the amount of waste (wet weight) incinerated, taking into account the dry matter content, the total carbon content, the fraction of fossil carbon and the oxidation factor. Default values for these factors can be found in Table 49:2.

$$\text{CO}_2 \text{ Emissions} = \sum_i (\text{SW}_i \times \text{dm}_i \times \text{CF}_i \times \text{FCF}_i \times \text{OF}_i) \times \frac{44}{12}$$

CO<sub>2</sub> Emissions = CO<sub>2</sub> emissions in inventory year, Gg/yr

SW<sub>i</sub> = total amount of solid waste of type i (wet weight) incinerated, Gg/yr

dm<sub>i</sub> = dry matter content in the waste (wet weight) incinerated, (fraction)

CF<sub>i</sub> = fraction of carbon in the dry matter (total carbon content), (fraction)

FCF<sub>i</sub> = fraction of fossil carbon in the total carbon, (fraction)

OF<sub>i</sub> = oxidation factor, (fraction)

$\frac{44}{12}$  = conversion factor from C to CO<sub>2</sub>

i = type of waste incinerated<sup>50</sup>

#### Method 2: IPCC Tier 2 — Waste Incineration – CO<sub>2</sub>

The Tier 2 method is based on country specific data regarding waste generation, composition and management practices of the data provider. The same equation from Tier 1 is used but this time with country specific data on waste composition and amount of waste incinerated.

#### Method 3: IPCC tier 3 — Waste Incineration – CO<sub>2</sub>

The Tier 3 method uses plant-specific data to estimate emissions from waste incineration. Parameters that affect both the fossil carbon content and the oxidation factor need to be considered. Factors affecting the oxidation factor include:

- type of installation/technology (fixed bed, stoker, fluidised bed, kiln)
- operation mode (continuous, semi-continuous, batch type)
- size of installation
- parameters such as the carbon content in the ash

<sup>50</sup> ISW: industrial solid waste, SS: sewage sludge, HW: hazardous waste, CW: clinical waste, other (that must be specified)



The total fossil CO<sub>2</sub> emissions from waste incineration are calculated as the sum of all plant specific fossil CO<sub>2</sub> emissions. It is suggested that all waste types are included as well as the entire amount incinerated and all types of incinerators in the inventory. The estimation is done similarly to the Tier 1 and Tier 2 methods.

### Methane emissions

#### Method 1: IPCC Tier 1 — Waste Incineration – CH<sub>4</sub>

The Tier 1 methodology is based on the amount of waste incinerated multiplied by a default emission factor.

#### Method 2: IPCC tier 2 — Waste Incineration – CH<sub>4</sub>

Tier 2 uses the same method as Tier 1, however, country specific data is used for emission factors.

#### Method 3: IPCC Tier 3 — Waste Incineration – CH<sub>4</sub>

The Tier 3 methodology uses plant specific data and sums the emissions derived from calculations such as mass balance calculations.

### 49.3. Activity Data

The activity data is the waste inputs into the incinerator expressed in mass of waste consumed. It is important to record the nature of the data – whether it is based on wet matter or dry matter.

### 49.4. Parameters/Emission Factors

Tier 1 emission factors for waste incineration for CO<sub>2</sub> are listed below:

**Table 49:2:** Default data for CO<sub>2</sub> emission factors for incineration (based on table 5.2 IPCC 2006 Volume 5, Chapter 5)

Parameters	Industrial Waste (%)	Clinical Waste (%)	Sewage Sludge (%) Note 4	Fossil liquid waste (%) Note 5
Dry matter content in % of wet weight	NA	NA	NA	NA
Total carbon content in % of dry weight	50	60	40 – 50	80
Fossil carbon fraction in % of total carbon content	90	40	0	100
Oxidation factor in % of carbon input	100	100	100	100

Tier 1 emission factors for waste incineration for CH<sub>4</sub> are listed below:

**Table 49:3:** CH<sub>4</sub> Emission factors for incineration of municipal solid waste (MSW)

Type of incineration/technology		CH <sub>4</sub> Emission Factors (kg/Gg waste incinerated on a wet weight basis)
Continuous incineration	stoker	0.2
	fluidised bed	~0
Semi-continuous incineration	stoker	6
	fluidised bed	188
Batch type incineration	stoker	60
	fluidised bed	237

Parameters and emission factors for Tier 2 and Tier 3 methodologies respectively will depend on site specific data and analysis.

## 50. Poultry (Installations for the intensive rearing of poultry)

The threshold for Poultry (Installations for the intensive rearing of poultry) is 40 000 places for poultry. This means that if the data provider has 40 000 places for poultry farming, they have to report the methane and nitrous oxide emissions from the manure management from poultry including chicken, broilers, turkeys, and duck. Poultry activities include breeding, hatching, laying and etc.

Poultry manure are produced on poultry farming and are a significant contributor to greenhouse gas emissions. This includes CH<sub>4</sub> and N<sub>2</sub>O emissions produced during the storage and treatment of manure. Manure management systems includes:

- Poultry manure with litter- Similar to deep bedding systems. Typically used for all poultry breeder flocks and for the production of meat type chickens (broilers) and other fowl.
- Poultry manure without litter- May be similar to open pits in enclosed animal confinement facilities or may be designed and operated to dry the manure as it accumulates.

Methane, a greenhouse gas, is produced from the decomposition of livestock manure under anaerobic conditions. These conditions often occur when large numbers of poultry such as chickens, turkeys, ducks, and geese are managed in a confined area (e.g., poultry farms) where manure is typically stored in large piles or disposed of in lagoons. Nitrous oxide (N<sub>2</sub>O, also a greenhouse gas, is produced during the nitrification-denitrification of nitrogen contained in poultry manure.

### 50.1. IPCC Classification

In the table below, emission source is correlated to the IPCC reporting category as relevant for the GHG Reporting Regulations.

Table 50:1: IPCC classification for Poultry (Installations for the intensive rearing of poultry)

Sector	Relevant IPCC code/s	Definition	Relevant IPCC gases	Tier	Methodology reference	Transitional arrangements (regulation 15)
AFOLU-Poultry (Installations for the	3A2i	Methane and nitrous oxide emissions	CH <sub>4</sub>	Tier 1, 2 or 3	Volume 4, Chapter 10 of the 2006 IPCC Guidelines.	No

Sector	Relevant IPCC code/s	Definition	Relevant IPCC gases	Tier	Methodology reference	Transitional arrangements (regulation 15)
intensive rearing of poultry)		from Manure Management.	N <sub>2</sub> O	Tier 1, 2 or 3	Volume 4, Chapter 10 of the 2006 IPCC Guidelines.	No
1A Fuel Combustion Activities	1A4c	Agriculture / Forestry / Fishing / Fish Farms	CO <sub>2</sub>	Tier 1, 2 or 3	Section 12	Yes
			CH <sub>4</sub>	Tier 1, 2 or 3	Section 12	No
			N <sub>2</sub> O	Tier 1, 2 or 3	Section 12	No

## 50.2. Methodology

### CH<sub>4</sub> emissions from poultry manure management

The main factors affecting CH<sub>4</sub> emissions are the amount of manure produced and the portion of the manure that decomposes anaerobically. This also depends on the rate of waste production per animal and the number of animals, and the latter on how the manure is managed. When manure is stored or treated as a liquid (e.g., in lagoons, ponds, tanks, or pits), it decomposes anaerobically and can produce a significant quantity of CH<sub>4</sub>. The temperature and the retention time of the storage unit greatly affect the amount of methane produced. When manure is handled as a solid (e.g., in stacks or piles) or when it is deposited on pastures and rangelands, it tends to decompose under more aerobic conditions and less CH<sub>4</sub> is produced. The methodology to determine the emissions associated with Poultry (Installations for the intensive rearing of poultry) is detailed in Volume 4, Chapter 10 of the 2006 IPCC Guidelines.

#### Method 1: IPCC Tier 1

When using the Tier 1 method, default emission factors by average annual temperature are used.

Step 1: Estimates the annual average of livestock population.

$$AAP = \text{Days alive} * (\text{NAPA}/365)$$

Where:

AAP = annual average population

NAPA = number of animals produced annually

Broiler chickens are typically grown approximately 60 days before slaughter. Estimating the average annual population as the number of birds grown and slaughtered over the course

of a year would greatly overestimate the population, as it would assume each bird lived the equivalent of 365 days. Instead, one should estimate the average annual population as the number of animals grown divided by the number of growing cycles per year. For example, if broiler chickens are typically grown in flocks for 60 days, an operation could turn over approximately 6 flocks of chickens over the period of one year. Therefore, if the operation grew 60,000 chickens in a year, their average annual population would be 9,863 chickens. For this example, the equation would be: Annual average population = 60 days • 60,000 / 365 days / yr<sup>-1</sup> = 9,863 chickens

Step 2: Estimate CH<sub>4</sub> emissions from manure management

$$CH_{4manure} = \sum_{(T)} \frac{(EF_{(T)} \cdot N_{(T)})}{10^6}$$

Where:

CH<sub>4</sub> Manure = CH<sub>4</sub> emissions from manure management, for a defined population, Gg CH<sub>4</sub> yr<sup>-1</sup>

EF(T) = emission factor for the defined livestock population, kg CH<sub>4</sub> head<sup>-1</sup> yr<sup>-1</sup>

N(T) = the number of head of livestock species/category T in the country

T = species/category of livestock

To accurately calculate CH<sub>4</sub> and N<sub>2</sub>O emissions from Poultry (Installations for the intensive rearing of poultry), it is suggested that the templates is used. The templates can be downloaded from the SAGERS landing page.

### Method 2: IPCC Tier 2

The Tier 2 method is similar to Tier 1 except it allows for incorporation of country specific emission factors and country specific activity data. This method requires detailed information on animal characteristics and manure management practices, which is used to develop emission factors specific to the conditions of the country. The Tier 2 method relies on two primary types of inputs that affect the calculation of methane emission factors from manure:

Manure characteristics: Includes the amount of volatile solids (VS) produced in the manure and the maximum amount of methane able to be produced from that manure (Bo). Production of manure VS can be estimated based on feed intake and digestibility. Alternatively, VS production rates can be based on laboratory measurements of livestock manure. Bo varies by animal species and feed regimen and is a theoretical methane yield based on the amount of VS in the manure.

Manure management system characteristics: Includes the types of systems used to manage manure and a system-specific methane conversion factor (MCF) that reflects the portion of  $B_o$  that is achieved. Regional assessments of manure management systems are used to estimate the portion of the manure that is handled with each manure management technique. A description of manure management systems is included in Table 10.18. The system MCF varies with the manner in which the manure is managed and the climate, and can theoretically range from 0 to 100%. Both temperature and retention time play an important role in the calculation of the MCF. Manure that is managed as a liquid under warm conditions for an extended period of time promotes methane formation. These manure management conditions can have high MCFs, of 65 to 80%. Manure managed as dry material in cold climates does not readily produce methane, and consequently has an MCF of about 1%.

Development of Tier 2 emission factors involves determining a weighted average MCF using the estimates of the manure managed by each waste system within each climate region. The average MCF is then multiplied by the VS excretion rate and the  $B_o$  for the livestock categories. In equation form, the estimate is as follows:

#### CH<sub>4</sub> EMISSION FACTOR FROM MANURE MANAGEMENT

$$EF_{(T)} = (VS_T \cdot 365) \cdot \left[ B_{o(T)} \cdot 0.67 \text{ kg m}^{-3} \cdot \sum_{S,k} \frac{MCF_{S,k}}{100} \cdot MS_{(T,S,k)} \right]$$

Where:

$EF(T)$  = annual CH<sub>4</sub> emission factor for livestock category T, kg CH<sub>4</sub> animal<sup>-1</sup> yr<sup>-1</sup>

$VS(T)$  = daily volatile solid excreted for livestock category T, kg dry matter animal<sup>-1</sup> day<sup>-1</sup>

365 = basis for calculating annual VS production, days yr<sup>-1</sup>

$B_o(T)$  = maximum methane producing capacity for manure produced by livestock category T, m<sup>3</sup> CH<sub>4</sub> kg<sup>-1</sup> of VS excreted

0.67 = conversion factor of m<sup>3</sup> CH<sub>4</sub> to kilograms CH<sub>4</sub>

$MCF(S,k)$  = methane conversion factors for each manure management system S by climate region k, %

$MS(T,S,k)$  = fraction of livestock category T's manure handled using manure management system S in climate region k, dimensionless

#### VS excretion rates

Volatile solids (VS) are the organic material in livestock manure and consist of both biodegradable and nonbiodegradable fractions. The best way to obtain average daily VS excretion rates is to use data from nationally published sources. If average daily VS excretion rates are not available, country-specific VS excretion rates can be estimated from feed intake levels.

The VS content of manure equals the fraction of the diet consumed that is not digested and thus excreted as fecal material which, when combined with urinary excretions, constitutes manure. Countries should estimate gross energy (GE) intake and its fractional digestibility, DE, in the process of estimating enteric methane emissions. Once these are estimated, the VS excretion rate is estimated as:

#### **VOLATILE SOLID EXCRETION RATES**

$$VS_T = \left[ GE \cdot \left( 1 - \frac{DE\%}{100} \right) + (UE \cdot GE) \right] \cdot \left[ \left( \frac{1 - ASH}{18.45} \right) \right]$$

Where:

VS = volatile solid excretion per day on a dry-organic matter basis, kg VS day<sup>-1</sup>

GE = gross energy intake, MJ day<sup>-1</sup>

DE% = digestibility of the feed in percent

(UE • GE) = urinary energy expressed as fraction of GE

ASH = the ash content of manure calculated as a fraction of the dry matter feed intake

18.45 = conversion factor for dietary GE per kg of dry matter (MJ kg<sup>-1</sup>). This value is relatively constant across a wide range of forage and grain-based feeds commonly consumed by livestock.

Representative DE% values for various livestock categories are provided in Section 10.2, Table 10.2, Volume 4, Chapter 10 of 2006 IPCC guidelines.

#### **Bo values**

The maximum methane-producing capacity of the manure (Bo) varies by species and diet. The preferred method to obtain Bo measurement values is to use data from country-specific published sources, measured with a standardised method. It is important to standardise the Bo measurement, including the method of sampling, and to confirm if the value is based on total as-excreted VS or biodegradable VS, since the Tier 2 calculation is based on total as-excreted VS.

#### **MCFs**

MCFs are determined for a specific manure management system and represent the degree to which Bo is achieved. The amount of methane generated by a specific manure management system is affected by the extent of anaerobic conditions present, the temperature of the system, and the retention time of organic material in the system. Therefore, country-specific MCFs that reflect the specific management systems used in particular countries or regions should be developed if possible.

Measurements should include the following factors:

- Timing of storage/application;
- Feed and animal characteristics at the measurement site (see Section 10.2 for the type of data that would be pertinent);
- Length of storage;

- Manure characteristics (e.g., VS influent and effluent concentrations for liquid systems);
- Determination of the amount of manure left in the storage facility (methanogenic inoculum);
- Time and temperature distribution between indoor and outdoor storage;
- Daily temperature fluctuation; and
- Seasonal temperature variation.

### Method 3: IPCC Tier 3

The Tier 3 method is a country specific method based on site specific data. The data provider can go beyond the Tier 2 method and develop models for country-specific methodologies or use measurement-based approaches to quantify emission factors. This include accurate and well designed emission measurements from well characterised types of manure and manure management systems. These measurements must account for temperature, moisture conditions, aeration, VS content, duration of storage, and other aspects of treatment.

### Direct N<sub>2</sub>O emissions from Manure Management

#### Method 1: IPCC Tier 1

The Tier 1 method entails multiplying the total amount of N excretion from poultry in each type of manure management system by an emission factor for that type of manure management system. Emissions are then summed over all manure management systems. The Tier 1 method is applied using IPCC default N<sub>2</sub>O emission factors, default nitrogen excretion data, and default manure management system data (see Annex H for default management system allocations).

The calculation of direct N<sub>2</sub>O emissions from manure management is based on the following equation:

$$N_2OD (mm) = ((s \sum(T \sum(N(T) * Nex(T) * MS(S,T))) * EF3) * 44/28$$

Where:

N<sub>2</sub>OD(mm) = direct N<sub>2</sub>O emissions from Manure Management in the country, kg N<sub>2</sub>O yr<sup>-1</sup>  
<sup>1</sup>N(T) = number of head of livestock species/category T in the country

Nex(T) = annual average N excretion per head of species/category T in the country, kg N animal<sup>-1</sup> yr<sup>-1</sup>

MS(T,S) = fraction of total annual nitrogen excretion for each livestock species/category T that is managed in manure management system S in the country, dimensionless

EF3(S) = emission factor for direct N<sub>2</sub>O emissions from manure management system S in the country, kg N<sub>2</sub>O-N/kg N in manure management system S



S = manure management system

T = species/category of livestock

44/28 = conversion of (N<sub>2</sub>O-N) (mm) emissions to N<sub>2</sub>O(mm) emissions

### Method 2: IPCC Tier 2

A Tier 2 method follows the same calculation equation as Tier 1 but would include the use of country-specific data for some or all of these variables. For example, the use of country-specific nitrogen excretion rates for livestock categories would constitute a Tier 2 methodology.

$$Nex_T = Nintake_T \cdot (1 - Nretention_{frac_T}) \cdot 365$$

Where

Nex (T) is the annual N excretion rates (Kg N animal<sup>-1</sup> yr<sup>-1</sup>),

N intake (T) is the annual N intake per head of animal of species/category T (Kg N animal<sup>-1</sup> yr<sup>-1</sup>),

Nretention (T) is the fraction of annual N intake that is retained by animal of species/category T (dimensionless).

N intake rates is calculated using:

$$N_{intake} = \frac{GE}{18.45} \cdot \left( \frac{CP\%}{6.25} \right)$$

Nintake(T) is daily N consumed per animal of category T, kg N animal<sup>-1</sup> day<sup>-1</sup>,

CP% is percent crude protein in diet, input; 6.25 is conversion from kg of dietary protein to kg of dietary N, kg feed protein (kg N)<sup>-1</sup>;

### Method 3: IPCC Tier 3

A Tier 3 method utilizes alternative estimation procedures based on a country-specific methodology. For example, a process-based, mass balance approach which tracks nitrogen throughout the system starting with feed input through final use/disposal could be utilized as a Tier 3 procedure. Tier 3 methods should be well documented to clearly describe estimation procedures.

### **50.3. Activity Data**

For detailed guidance on choice of activity data please refer to section 10.4.3 and 10.5.3 in Volume 4, Chapter 10 of the 2006 IPCC Guidelines.

### **50.4. Emission Factors**

For detailed guidance on choice of emission factors please refer to section 10.4.2 and 10.5.2 in Volume 4, Chapter 10 of the 2006 IPCC Guidelines. The default factors to estimate poultry manure management emissions can be sourced from Annexure H.

## 51. Forestland Remaining Forestland

- (a) The “forest” definition from the National Forest Act (Act 84 of 1998) (NFA) which states that:
- i) “forest” includes a natural forest, a woodland and a plantation (Section 1(2)(x) of NFA);
  - ii) “natural forest” means a group of trees whose crowns are largely contiguous, or which have been declared by the Minister to be a natural forest (Section 1(2)(xx) of NFA);
  - iii) “plantation” means a group of trees cultivated for exploitation of the wood, bark, leaves or essential oils (Section 1(2)(xxii) of NFA); and
  - iv) “woodland” means a group of indigenous trees which are not a natural forest, but whose crowns cover more than five percent of the area bounded by the trees forming the perimeter of the group (Section 1(2)(xxxix) of NFA).

However, in order to facilitate a robust reporting and accounting system for forestry under the Greenhouse Gas (GHG) Reporting Regulations, using the Marrakech accord as a guide, a forest is defined as follows:

“Forest” is defined as having a minimum area of land of 1.0 ha with tree crown cover (or equivalent stocking level) of more than 30 % with trees with the potential to reach a minimum height of 5 metres at maturity in situ. A forest may consist either of closed forest formations where trees of various storeys and undergrowth cover a high proportion of the ground or open forest. Young natural stands and all plantations which have yet to reach a crown density of 30 % or tree height of 5 metres are included under forest, as are areas normally forming part of the forest area which are temporarily unstocked as a result of human intervention such as harvesting or natural causes but which are expected to revert to forest.

This section deals with managed forests that have been under Forest Land for over 20 years (default), or for over a country-specific transition period. Greenhouse gas inventory for Forest Land Remaining Forest Land (FF) involves estimation of changes in carbon stock from five carbon pools (i.e., above-ground biomass, belowground biomass, dead wood, litter, and soil organic matter), as well as emissions of non-CO<sub>2</sub> gases.

### 51.1. IPCC Classification

In the table below, emission source is correlated to the IPCC reporting category as relevant for the GHG Reporting Regulations.

Table 51.1: IPCC classification for Forestland Remaining Forestland

Sector	Relevant IPCC code/s	Definition	Relevant IPCC gases	Tier	Methodology reference	Transitional arrangements (regulation 15)
AFOLU- Forestland Remaining Forestland	3B1a	Forest Land Remaining Forest Land (FF) involves estimation of changes in carbon stock from five carbon pools (i.e., above-ground biomass, belowground biomass, dead wood, litter, and soil organic matter), as well as emissions of non-CO <sub>2</sub> gases.	CO <sub>2</sub>	Tier 1, 2 or 3	Carbon Sequestration guidelines	Yes

### 51.2. Methodology

The methodology to determine the emissions associated with Forestland Remaining Forestland is detailed in the Methodological Guidelines for Quantification of Greenhouse Gas Emissions – Carbon Sequestration in the Forestry Industry. To accurately calculate emissions from Forestland Remaining Forestland, the MRV tool for carbon sequestration guidelines must be used. The tool can be downloaded from the SAGERS landing page: <https://ghgreporting-public.environment.gov.za/GHGLanding/SAGERSHome.html>.

## 52. Land Converted to Forest Land

The emission factors required for estimating carbon stock changes for Land Converted to Forest Land are nearly identical to those required for Forest Land Remaining Forest Land but refers to lands converted to forests within 20 years of the inventory year (default period of conversion).

### 52.1. IPCC Classification

Table 52:1: IPCC classification for Land converted to Forest land

Sector	Relevant IPCC code/s	Definition	Relevant IPCC gases	Tier	Methodology reference	Transitional arrangements (regulation 15)
AFOLU-Land converted to Forestland	3B1b	Land converted to Forestland involves annual estimation of emissions and removals of greenhouse gases, which occur on lands converted to Forest Land from different land-uses, including Cropland, Grassland, Wetlands, Settlements, and Other land, through afforestation and reforestation, either by natural or artificial regeneration (including plantations). The emissions and removals on abandoned lands, which are regenerating to forest due to human activities, should be also estimated under this section.	CO <sub>2</sub>	Tier 1, 2 or 3	Volume 4, Chapter 4 of the 2006 IPCC Guidelines.	Yes

### 52.2. Methodology

The methodology to determine the emissions associated with Forestland Remaining Forestland is detailed in the Methodological Guidelines for Quantification of Greenhouse Gas Emissions – Carbon Sequestration in the Forestry Industry.

CONTINUES ON PAGE 258 OF BOOK 3

Printed by and obtainable from the Government Printer, Bosman Street, Private Bag X85, Pretoria, 0001  
Contact Centre Tel: 012-748 6200. eMail: info.egazette@gpw.gov.za  
Publications: Tel: (012) 748 6053, 748 6061, 748 6065



# Government Gazette Staatskoerant

REPUBLIC OF SOUTH AFRICA  
REPUBLIEK VAN SUID AFRIKA

Vol. 688

7

October  
Oktober

2022

No. 47257

**PART 3 OF 4**

N.B. The Government Printing Works will not be held responsible for the quality of "Hard Copies" or "Electronic Files" submitted for publication purposes

ISSN 1682-5845



9 771682 584003



**AIDS HELPLINE: 0800-0123-22 Prevention is the cure**

### 53. Biomass Burning in Forest Lands

Biomass burning entails the emissions of CO<sub>2</sub>, CH<sub>4</sub> and N<sub>2</sub>O gases. Two types of fires are described below: wildfires and controlled burning:

- Controlled burning is limited to the burning of the remaining residue and litter following the removal of wood to mills. Emissions from burning of vegetation in firebreaks are not considered to be significant and therefore are not reported.
- Wildfires are limited to those affected forest areas within the plantation, i.e. wildfires occurring in grassland areas within the plantation are not estimated nor reporting.

#### 53.1. IPCC Classification

In the table below, emission source is correlated to the IPCC reporting category as relevant for the GHG Reporting Regulations.

Table 53:1: IPCC classification for Biomass Burning in Forest Lands

Sector	Relevant IPCC code/s	Definition	Relevant IPCC gases	Tier	Methodology reference	Transitional arrangements (regulation 15)
AFOLU-Biomass Burning in Forest Lands	3C1a	Non-CO <sub>2</sub> greenhouse gas emissions from forests	CO <sub>2</sub>	Tier 1, 2 or 3	Carbon Sequestration guidelines	No
			CH <sub>4</sub>	Tier 1, 2 or 3	Carbon Sequestration guidelines	No
			N <sub>2</sub> O	Tier 1, 2 or 3	Carbon Sequestration guidelines	No

#### 53.2. Methodology

The methodology to determine the emissions associated with Biomass Burning in Forest Lands is detailed in the Methodological Guidelines for Quantification of Greenhouse Gas Emissions – Carbon Sequestration in the Forestry Industry.



## 54. Direct N<sub>2</sub>O Emissions from Managed Soils

The application of fertilisers results in human-induced net N additions to soils (e.g. organic fertilisers such as deposited manure, crop residues, sewage sludge and synthetic fertilisers) and consequentially N<sub>2</sub>O emissions. Formally termed “direct emissions from the application of fertiliser”, it does not include the emissions generated through the production and supply of the fertiliser, only the N<sub>2</sub>O emissions generated where they are applied. Only synthetic N fertilisers are assumed to be used, i.e. methodology to estimate emissions due to the use of organic fertilisers is not included.

### 54.1. IPCC Classification

In the table below, direct emission source is correlated to the IPCC reporting category as relevant for the GHG Reporting Regulations.

Table 54:1: IPCC classification for Direct N<sub>2</sub>O Emissions from Managed Soils

Sector	Relevant IPCC code/s	Definition	Relevant IPCC gases	Tier	Methodology reference	Transitional arrangements (regulation 15)
AFOLU-Direct N <sub>2</sub> O Emissions from Managed Soils	3C4	N <sub>2</sub> O emissions synthetic N fertilisers	N <sub>2</sub> O	Tier 1, 2 or 3	Carbon Sequestration guidelines	No

### 54.2. Methodology

The methodology to determine the emissions associated with Direct N<sub>2</sub>O Emissions from Managed Soils is detailed in the Methodological Guidelines for Quantification of Greenhouse Gas Emissions – Carbon Sequestration in the Forestry Industry.

## 55. Indirect N<sub>2</sub>O Emissions from Managed Soils

The direct emissions of N<sub>2</sub>O from managed soils that occur through a direct pathway (i.e., directly from the soils to which N is applied), emissions of N<sub>2</sub>O also take place through two indirect pathways. The first of these pathways is the volatilisation of N as NH<sub>3</sub> and oxides of N (NO<sub>x</sub>), and the deposition of these gases and their products NH<sub>4</sub><sup>+</sup> and NO<sub>3</sub><sup>-</sup> onto soils and the surface of lakes and other waters. Thus, these processes cause N<sub>2</sub>O emissions in an exactly analogous way to those resulting from deposition of agriculturally derived NH<sub>3</sub> and NO<sub>x</sub>, following the application of synthetic and organic N fertilisers and. The second pathway is the leaching and runoff from land of N from synthetic and organic fertiliser additions.

### 55.1. IPCC Classification

In the table below, indirect emission source is correlated to the IPCC reporting category as relevant for the GHG Reporting Regulations.

**Table 55.1: IPCC classification for Indirect N<sub>2</sub>O Emissions from Managed Soils**

Sector	Relevant IPCC code/s	Definition	Relevant IPCC gases	Tier	Methodology reference	Transitional arrangements (regulation 15)
AFOLU- Indirect N <sub>2</sub> O Emissions from Managed Soils	3C5		N <sub>2</sub> O	Tier 1, 2 or 3	Carbon Sequestration guidelines	No

### 55.2. 50.2 Methodology

The methodology to determine the emissions associated with Indirect N<sub>2</sub>O Emissions from Managed Soils is detailed in the Methodological Guidelines for Quantification of Greenhouse Gas Emissions – Carbon Sequestration in the Forestry Industry.

## 56. Harvested Wood Products (HWP)

HWP includes all wood material (including bark) that leaves harvest sites. Slash and other material left at harvest sites should be regarded as dead organic matter in the associated land-use category.

### 56.1. IPCC Classification

In the table below, emission source is correlated to the IPCC reporting category as relevant for the GHG Reporting Regulations.

Table 56:1: IPCC classification for Harvested Wood Products

Sector	Relevant IPCC code/s	Definition	Relevant IPCC gases	Tier	Methodology reference	Transitional arrangements (regulation 15)
AFOLU-Harvested Wood Products	3D1	Emissions from all wood material (including bark) that leaves harvest sites.	CO <sub>2</sub>	Tier 1, 2 or 3	Carbon Sequestration guidelines	NO

### 56.2. Methodology

The methodology to determine the emissions associated with Harvested Wood Products is detailed in the Methodological Guidelines for Quantification of Greenhouse Gas Emissions – Carbon Sequestration in the Forestry Industry.

## References

- DEA, 2011. National Climate Change Response White Paper. Pretoria, RSA.  
[https://www.environment.gov.za/sites/default/files/legislations/national\\_climate\\_change\\_response\\_whitepaper.pdf](https://www.environment.gov.za/sites/default/files/legislations/national_climate_change_response_whitepaper.pdf)
- Department of Environmental Affairs (DEA), 2014. GHG National Inventory Report South Africa 2000–2010. Pretoria: DEA.
- DEA, 2016. National Environmental Management: Air Quality Act, 2004 (Act No. 39 of 2004): National Greenhouse Gas Emission Reporting Regulations. In Government Gazette, Republic of South Africa, Vol. 612, 7 June 2016, No. 40054. Pretoria: Government Printing Works.  
[https://www.environment.gov.za/sites/default/files/gazetted\\_notices/nemaqa39of2004\\_draftnationalgreenhousegas\\_emissionreportingregulations\\_gn40054.pdf](https://www.environment.gov.za/sites/default/files/gazetted_notices/nemaqa39of2004_draftnationalgreenhousegas_emissionreportingregulations_gn40054.pdf)
- de Beer J, Phylipsen D and Bates J, 2001. Economic evaluation of carbon dioxide and nitrous oxide emission reductions in industry in the EU: Bottom-up analysis. Contribution to a Study for DG Environment, European Commission by Ecofys Energy and Environment, AEA Technology Environment and National Technical University of Athens.  
[http://ec.europa.eu/environment/enveco/climate\\_change/pdf/industry.pdf](http://ec.europa.eu/environment/enveco/climate_change/pdf/industry.pdf)
- Doorn et al, 1997. Estimate of Global Greenhouse Gas Emissions from Industrial and Domestic Wastewater Treatment, Final Report, EPA-600/R-97-091, Prepared for United States Environmental Protection Agency, Research Triangle Park, NC, USA.
- Dunn, R, 2001. Diesel fuel quality and locomotive emissions in Canada. Transport Canada Publication number Tp 13783e (Table 8).
- European Environmental Agency (EEA), 2005. Emission Inventory Guidebook – 2005 European Environment Agency, Technical report No 30. Copenhagen, Denmark, (December 2005). Available from web site:  
[http://reports.eea.eu.int/EMEP\\_CORINAIR4/en](http://reports.eea.eu.int/EMEP_CORINAIR4/en)
- European Fertilizer Producers' Association (EFMA), 2000. Best Available Techniques for Pollution Prevention and Control in the European fertilizer Industry: Production of Ammonia, Booklet No. 1 of 8. Brussels, EFMA.  
[http://www.fertilizerseurope.com/fileadmin/user\\_upload/user\\_upload\\_prodste/w/documents/Booklet\\_nr\\_1\\_Production\\_of\\_Ammonia.pdf](http://www.fertilizerseurope.com/fileadmin/user_upload/user_upload_prodste/w/documents/Booklet_nr_1_Production_of_Ammonia.pdf)
- IPCC, 1996. Chapter 1: Energy in Revised 1996 IPCC Guidelines for National Greenhouse Gas Inventories: Reference Manual (Vol 3) <http://www.ipcc-nggip.iges.or.jp/public/gl/invs6.html>
- IPCC, 2001. Climate Change 2001 – Third Assessment Report. Working Group 1: The Scientific Basis. Chapter 6: Radiative Forcing of Climate Change.  
[http://www.grida.no/publications/other/ipcc\\_tar/?src=/climate/ipcc\\_tar/wg1/247.htm](http://www.grida.no/publications/other/ipcc_tar/?src=/climate/ipcc_tar/wg1/247.htm)
- IPCC, 2006. 2006 IPCC Guidelines for National Greenhouse Gas Inventories. Geneva; IPCC. <http://www.ipcc-nggip.iges.or.jp/public/2006gl/>

- GHG Protocol, 2004. Corporate Accounting and Reporting Standard. Geneva: World Business Council; Washington DC, World Resources Institute.
- Lloyd P and Cook A, 2005. Methane release from South African coal mines J SA Inst Min Metall.105pp 483-490 Aug 2005.
- National Planning Commission (NPC), 2011. National Development Plan 2030: Vision for 2030. Pretoria: Government Printer. Available at [http://www.gov.za/sites/www.gov.za/files/devplan\\_2.pdf](http://www.gov.za/sites/www.gov.za/files/devplan_2.pdf)
- Singh, Neelam; Bacher, Kathryn; Song, Ranping; Sotos, Mary; Yin, Lei. 2015. Guide for designing mandatory greenhouse gas reporting programs. Washington, D.C. : World Bank Group.  
<http://documents.worldbank.org/curated/en/166511467986284360/Guide-for-designing-mandatory-greenhouse-gas-reporting-programs>
- Raanes, O 1991. Silisiumkarbid og CO<sub>2</sub>, STF34 A91134. SINTEF.
- UNFCCC, 1992. United Nations Framework Convention on Climate Change. New York: United Nations.
- UNFCCC, 2003. Report of the Conference of the Parties on its eighth session, held at New Delhi from 23 October to 1 November 2002. fccc/cp/2002/7/add.2, p2. <http://unfccc.int/resource/docs/cop8/07a02.pdf>

## ANNEXURES

## Annexure A: Stationary Combustion – Emission factors

The table below details the default emission factors for energy (Tables 1.4 and 2.2 in Volume 2 Energy Chapters 1&2 of the 2006 IPCC Guidelines.)

Table A.1: Default Emission Factors and Net Calorific Values for **Stationary** Combustion – (solid, liquid and gaseous fuels)

Fuel Type	CO <sub>2</sub> (kgCO <sub>2</sub> /TJ)	CH <sub>4</sub> (kgCH <sub>4</sub> /TJ)	N <sub>2</sub> O (kgN <sub>2</sub> O/TJ)	Default Calorific Value (TJ/Tonne)
Anthracite	98,300	1	1.5	0.0267
Aviation Gasoline	70,000	3	0.6	0.0443
Acetylene <sup>51</sup>	67,870	NA	NA	0.049818
Biodiesel	70,800	3	0.6	0.027
Biogasoline	70,800	3	0.6	0.027
Bitumen	80,700	3	0.6	0.0402
BLast Furnace Gas	260,000	1	0.1	0.00247
Brown Coal Briquettes	97,500	1	1.5	0.0207
Charcoal	112,000	200	4	0.0295
Coal Tar	80,700	1	1.5	0.028
Coke Oven Coke & Lignite Coke	107,000	1	1.5	0.0282
Coke Oven Gas	44,400	1	0.1	0.0387
Coking Coal	94,600	1	1.5	0.0282
Crude Oil	73,300	3	0.6	0.0438
Diesel	74,100	3	0.6	0.043
Ethane	61,600	1	0.1	0.0464
Gas Coke	107,000	1	0.1	0.0173
Gas Works Gas	44,400	1	0.1	0.0387
Industrial Wastes	143,000	30	4	NA
Jet Gasoline	70,000	3	0.6	0.0443
Jet Kerosene	71,500	3	0.6	0.0441
Landfill Gas	54,600	1	0.1	0.0504
Lignite	101,000	1	1.5	0.0119
Liquefied Petroleum Gases	63,100	1	0.1	0.0473
Lubricants	73,300	3	0.6	0.0402
Municipal Wastes (Biomass Fraction)	100,000	30	4	0.0116
Municipal Wastes (Non Biomass Fraction)	91,700	30	4	0.01
Naphtha	73,700	3	0.6	0.0445
Natural Gas	56,100	1	0.1	0.048
Natural Gas Liquids	64,200	3	0.6	0.041

<sup>51</sup> Not available in the IPCC Emissions Factor database but it is available in this study (<https://www2.gov.bc.ca/assets/gov/environment/climate-change/cng/methodology/2011-pso-methodology.pdf>) and this is the assumed emissions factor for South Africa until further dedicated study is conducted for the country.

Fuel Type	CO <sub>2</sub> (kgCO <sub>2</sub> /TJ)	CH <sub>4</sub> (kgCH <sub>4</sub> /TJ)	N <sub>2</sub> O (kgN <sub>2</sub> O/TJ)	Default Calorific Value (TJ/Tonne)
Oil Shale & Tar Sands	107,000	1	1.5	0.0089
Orimulsion	77,000	3	0.6	0.0275
Other Biogas	54,600	1	0.1	0.0504
Other Bituminous Coal	94,600	1	1.5	0.0192
Other Kerosene	71,900	3	0.6	0.037
Other Liquid Biofuels	79,600	3	0.6	0.0274
Other Petroleum Products	73,300	3	0.6	0.0402
Other Primary Solid Biomass	100,000	30	4	0.0116
Oxygen Steel Furnace Gas	182,000	1	0.1	0.00706
Paraffin	71,900	3	0.6	0.0438
Paraffin Waxes	73,300	3	0.6	0.0402
Patent Fuel	97,500	1	1.5	0.0207
Peat	106,000	1	1.5	0.00976
Petrol	69,300	3	0.6	0.0443
Petroleum Coke	97,500	3	0.6	0.0325
Refinery Feedstock	73,300	3	0.6	0.043
Refinery Gas	57,600	1	0.1	0.0495
Residual Fuel Oil (Heavy Fuel Oil)	77,400	3	0.6	0.0404
Shale Oil	73,300	3	0.6	0.0381
Sludge Gas	54,600	1	0.1	0.0504
Sub-Bituminous Coal	96,100	1	1.5	0.0192
Sulphite Lyes (Black Liquor)	95,300	3	2	0.0118
Waste Oils	73,300	30	4	0.0402
Waste Tyre	88,400	1	1,5	0.0325 <sup>52</sup>
White Spirit & SBP	73,300	3	0.6	0.0402
Wood/Wood Waste	112,000	30	4	0.0156

<sup>52</sup> This is based on the results of a study conducted in South Africa found at <https://ujcontent.uj.ac.za/vital/access/services/Download/uj:4939/CONTENT1>. There is a current study under the GHG Improvement programme that is looking at enhancing the emission factor and net calorific value for alternative fuels in South Africa. Once the study is concluded, the factors will be updated on SAGERS.



Table A.2: Default emission factors and net calorific values for mobile combustion

Fuel Type	CO <sub>2</sub> (kgCO <sub>2</sub> /TJ)	CH <sub>4</sub> (kgCH <sub>4</sub> /TJ)	N <sub>2</sub> O (kgN <sub>2</sub> O/TJ)	Default Calorific Value (TJ/Tonne)
Aviation Gasoline	70,000	0.5	2	0.0443
Compressed Natural Gas	56,100	92	3	N/A
Diesel	74,100	4.15	28.6	0.0381
Diesel - (Ocean-Going Ships)	74,100	7	2	0.0381
Diesel -Offroad	74,100	3.9	3.9	0.0381
Diesel-Rail	74,100	4.15	28.6	0.0381
Jet Kerosene	71,500	0.5	2	0.0441
Kerosene	71,900	3	0.6	0.037
Liquefied Natural Gases	56,100	92	3	NA
Liquefied Petroleum Gas	63,100	62	0.2	0.0473
Lubricants	73,300	3	0.6	0.0402
Natural Gas	56,100	92	3	0.048
(Paraffin) Other Kerosene	71,900	3	0.6	0.0438
Other Petroleum Products	73,300	3	0.6	0.0402
Paraffin Waxes	73,300	3	0.6	0.0402
Petrol	69,300	3.5	5.7	0.0443
Petrol-Oxidation Catalyst	69,300	25	8	0.0443
Petrol-Uncontrolled	69,300	33	3.2	0.0443
Refinery Gas	57,600	1	0.1	0.0495
Residual Fuel Oil - (Heavy Fuel Oil)	77,400	7	2	0.0404
Sub-bituminous Coal – Rail	96,100	2	1.5	0.0192
White Spirit & SBP	73,300	3	0.6	0.0402
Biodiesel	70,800	4.15	28.6	0.027
Biogasoline	70,800	3.5	5.7	0.027

Table A.3: Country specific CO<sub>2</sub> emission factors for stationary and mobile combustion: from the 2022 Liquid & Gas Fuel Study and 2022 Cement Study)

Fuel Type <sup>53</sup>	CO <sub>2</sub> (kgCO <sub>2</sub> /TJ)
Aviation Gasoline	65,752
Diesel	74,638
Heavy Fuel Oil	73,090
Jet Kerosene	73,463
LPG	64,852
Paraffin	64,640
Petrol	72,430
Refuse Derived Fuel	83,000
Sasol Methane Rich Gas (MRG)	54,888

<sup>53</sup> Development of Country-Specific CO<sub>2</sub> Emission Factors for Liquid and Gaseous Fuels in South Africa study report, 2022& 2022 Cement Study (Global Cement and Concrete Association (GCCA) The Cement CO<sub>2</sub> and Energy Protocol, Version 3 CO<sub>2</sub> and Energy Accounting and Reporting Standard for the Cement Industry)

Fuel Type <sup>53</sup>	CO <sub>2</sub> (kgCO <sub>2</sub> /TJ)
Sawdust	110,000
Waste Tyres	85,000

Note that the calorific values of the above fuels are found in Annexure D.

## Annexure B: Fugitive Emissions – Emission Factors

### Solid Fuels

Table B.1: Country specific emission factors for fugitive emissions from coal mining (Lloyd and Cook, 2005)

Mining method	Activity	GHG	South African specific Emission Factor (m <sup>3</sup> tonne <sup>-1</sup> )	
Underground Mining	Coal Mining	CH <sub>4</sub>	0.77	
	Post-mining (handling and transport)		0.18	
Surface Mining	Coal mining		0	
	Post-mining (storage and transport)		0	
Underground Mining	Coal mining		CO <sub>2</sub>	0.077
	Post-mining (storage and transport)			0.018
Surface Mining	Coal mining	0		
	Post-mining (storage and transport)	0		

### Fugitive Emissions

Table B.2: Default emission factors for fugitive emissions from coal mining, oil and gas operations (IPCC 2006)

IPCC Code	SOURCE CATEGORY ACTIVITY	CO <sub>2</sub>	CH <sub>4</sub>	N <sub>2</sub> O
1B1	<b>SOLID FUELS (M<sup>3</sup> / TONNE)</b>			
1B1a	<b>COAL MINING AND HANDLING</b>			
1B1ai	UNDERGROUND COAL MINING	0.077	0.77	
	UNDERGROUND POST-MINING (HANDLING & TRANSPORT)	0.018	0.18	
1B1aia	SURFACE COAL MINING	N/A	0	
	SURFACE POST-MINING (STORAGE AND TRANSPORT)	N/A	0	
1B1c2	Charcoal production (Fuel wood input) (kgCH <sub>4</sub> /TJ)	N/A	300	
	Charcoal production (Charcoal produced) (kgCH <sub>4</sub> /TJ)	N/A	1000	
1B2	<b>OIL AND NATURAL GAS (Gg/ 10<sup>3</sup>M<sup>3</sup> TOTAL OIL PRODUCTION)</b>			
1B2b	<b>NATURAL GAS</b>			
1B2b	<b>FLARING AND VENTING</b>			
1.B.2.b.ii	WELL DRILLING	0.0001	0.000033	ND
1.B.2.b.ii	WELL TESTING	0.009	0.000051	0.000000068
1.B.2.b.ii	WELL SERVICING	0.0000019	0.00011	ND

IPCC Code	SOURCE CATEGORY ACTIVITY	CO <sub>2</sub>	CH <sub>4</sub>	N <sub>2</sub> O
1B2b	<b>GAS PRODUCTION (Gg/ 10<sup>6</sup>M<sup>3</sup> TOTAL OIL PRODUCTION)</b>			
1.B.2.b.iii.2	FUGITIVES	1.40E-05	3.80E-04	NA
		to	to	
		8.20E-05	2.30E-03	
1.B.2.b.ii	FLARING	0.0012	0.00000076	0.000000021
	<b>GAS PROCESSING (Gg/ 10<sup>6</sup>M<sup>3</sup> RAW GAS FEED)</b>			
1.B.2.b.iii.3	SWEET GAS PLANTS-FUGITIVES	1.50E-04	4.80E-04	NA
		to	to	
		3.20E-04	1.03E-03	
1.B.2.b.ii	SWEET GAS PLANTS-FLARING	0.0018	0.0000012	0.000000025
1.B.2.b.iii.3	SOUR GAS PLANTS-FUGITIVES	0.0000079	0.000097	NA
1.B.2.b.ii	SOUR GAS PLANTS-FLARING	0.0036	0.0000024	0.000000054
1.B.2.b.i	SOUR GAS PLANTS -RAW CO <sub>2</sub> VENTING	0.063	NA	NA
1.B.2.b.iii.3	DEEP CUT EXTRACTION-FUGITIVES	0.0000016	0.000011	NA
1.B.2.b.ii	DEEP CUT EXTRACTION-FLARING	0.00011	0.000000072	0.000000012
1.B.2.b.iii.3	DEFAULT-FUGITIVES	1.20E-05	1.50E-04	NA
		to	to	
		3.20E-04	1.03E-03	
1.B.2.b.ii	DEFAULT-FLARING	0.003	0.000002	0.000000033
1.B.2.b.i	DEFAULT- RAW CO <sub>2</sub> VENTING	0.04	NA	NA
1B2b	<b>GAS TRANSMISSION &amp; STORAGE (Gg/year/km)</b>			
1.B.2.b.iii.4	TRANSMISSION - FUGITIVES	0.000016	0.0025	NA
1.B.2.b.i	TRANSMISSION - VENTING	0.0000085	0.0010	NA
1.B.2.b.iii.4	STORAGE (Gg-CO <sub>2</sub> /year/M <sup>3</sup> )		2.32E-09	ND
1B2b	<b>GAS DISTRIBUTION (Gg/ 10<sup>6</sup>M<sup>3</sup> OF UTILITY SALES)</b>			
1.B.2.b.iii.5	ALL	0.000051	0.0011	ND
1B2b	<b>NATURAL GAS LIQUIDS TRANSPORT (Gg/ 10<sup>3</sup>M<sup>3</sup> CONDENSATE AND PENTANES PLUS)</b>			
1.B.2.a.iii.3	CONDENSATE	0.0000072	0.00011	ND
1.B.2.a.iii.3	LIQUEFIED PETROLEUM GAS (Gg/ 10 <sup>3</sup> M <sup>3</sup> LPG)	0.00043	NA	2.20E-09
1.B.2.a.iii.3	LIQUEFIED NATURAL GAS (Gg/ 10 <sup>6</sup> M <sup>3</sup> MARKETABLE GAS)	ND	ND	ND
1B2a	<b>OIL</b>			
1B2a	<b>OIL PRODUCTION (Gg/ 10<sup>3</sup>M<sup>3</sup> CONVENTIONAL OIL PRODUCTION)</b>			
1.B.2.a.iii.2		1.10E-07	1.50E-06	NA

IPCC Code	SOURCE CATEGORY ACTIVITY	CO <sub>2</sub>	CH <sub>4</sub>	N <sub>2</sub> O
	CONVENTIONAL OIL-FUGITIVES (ONSHORE)	2.60E-04	3.60E-03	
1.B.2.a.iii.2	CONVENTIONAL OIL-FUGITIVES(OFFSHORE)	0.000000043	0.00000059	NA
1.B.2.a.i	CONVENTIONAL OIL-VENTING	0.000095	0.00072	NA
1.B.2.a.ii	CONVENTIONAL OIL-FLARING	0.041	0.000025	0.00000064
1B2a	<b>OIL PRODUCTION (Gg/ 10<sup>3</sup>M<sup>3</sup> HEAVY OIL PRODUCTION)</b>			
1.B.2.a.iii.2	HEAVY OIL/COLD BITUMEN - FUGITIVES	0.00054	0.0079	NA
1.B.2.a.i	HEAVY OIL/COLD BITUMEN - VENTING	0.0053	0.017	NA
1.B.2.a.ii	HEAVY OIL/COLD BITUMEN - FLARING	0.022	0.00014	0.00000046
1B2a	<b>OIL PRODUCTION (Gg/ 10<sup>3</sup>M<sup>3</sup> THERMAL BITUMEN PRODUCTION)</b>			
1.B.2.a.iii.2	THERMAL OIL PRODUCTION - FUGITIVES	0.000029	0.00018	NA
1.B.2.a.i	THERMAL OIL PRODUCTION - VENTING	0.00022	0.0035	NA
1.B.2.a.ii	THERMAL OIL PRODUCTION - FLARING	0.027	0.000016	0.00000024
1B2a	<b>OIL PRODUCTION (Gg/ 10<sup>3</sup>M<sup>3</sup> SYNTHETIC CRUDE PRODUCTION FROM OILSANDS)</b>			
1.B.2.a.iii.2	SYNTHETIC CRUDE (FROM OILSANDS)	ND	0.0023	ND
1.B.2.a.iii.2	SYNTHETIC CRUDE (OIL SHALE)	ND	ND	ND
1B2a	<b>OIL PRODUCTION (Gg/ 10<sup>3</sup>M<sup>3</sup> TOTAL OIL PRODUCTION)</b>			
1.B.2.a.iii.2	DEFAULT TOTAL - FUGITIVES	0.00028	0.0022	NA
1.B.2.a.i	DEFAULT TOTAL - VENTING	0.0018	0.0087	NA
1.B.2.a.ii	DEFAULT TOTAL - FLARING	0.034	0.000021	0.00000054
1B2a	<b>OIL UPGRADING (Gg/ 10<sup>3</sup>M<sup>3</sup> OIL UPGRADED)</b>			
1.B.2.a.iii.2	ALL	ND	ND	ND
1B2a	<b>OIL TRANSPORT (Gg/ 10<sup>3</sup>M<sup>3</sup> OIL TRANSPORTED BY PIPELINE)</b>			
1.B.2.a.iii.3	PIPELINES	0.00000049	0.0000054	NA
1B2a	<b>OIL TRANSPORT (Gg/ 10<sup>3</sup>M<sup>3</sup> OIL TRANSPORTED BY TANKER TRUCK)</b>			
1.B.2.a.i	TANKER TRUCKS AND RAIL CARS - VENTING	0.0000023	0.000025	NA
1B2a	<b>OIL TRANSPORT (Gg/ 10<sup>3</sup>M<sup>3</sup> OIL TRANSPORTED BY TANKER SHIPS)</b>			
1.B.2.a.i	LOADING OFF-SHORE PRODUCTION ON TANKER SHIPS - VENTING	ND	ND	ND
1B2a	<b>OIL REFINING (tonnes/ 10<sup>3</sup>M<sup>3</sup> OIL REFINED)</b>			
1.B.2.a.iii.4	ALL <sup>54</sup>	ND	2.6 x 10 <sup>-6</sup> to 4.1 x 10 <sup>-5</sup>	ND

<sup>54</sup> The factors include fugitive equipment leaks, flaring, storage of crude oil, handling and calcination

Table B.3: Default emission factors for fugitive emissions from coal mining, oil and gas operations (IPCC 2019 Refinements)

IPCC Code	SOURCE CATEGORY ACTIVITY	CO <sub>2</sub>	CH <sub>4</sub>	N <sub>2</sub> O
<b>1B1</b>	<b>SOLID FUELS (M<sup>3</sup> /TONNE)</b>			
<b>1B1cii</b>	Charcoal production ( per Charcoal produced) (Tonne GHG/Tonne Charcoal)	1.57	0.0403	8 x 10 <sup>-5</sup>
<b>1B1ciii</b>	Biochar production ( per biochar produced) (Tonne GHG/Tonne biochar)	4.3	0.03	ND
<b>1B1ci</b>	Coke production (per coke produced) (Tonnes GHG/ Tonne coke)	ND	4.9 x 10 <sup>-5</sup>	ND
<b>1B1civ</b>	<b>COAL TO LIQUIDS (TONNE GHG/TJ TOTAL OUTPUT)</b>			
<b>1B1civ</b>	Coal to Liquids - Syngas	55	0.0061	0
<b>1B1civ</b>	Coal to Liquids – Syngas/H <sub>2</sub>	55	0.0061	0
<b>1B1civ</b>	Coal to Liquids – SNG (synthetic natural gas)	78	0.0061	0
<b>1B1civ</b>	<b>GAS TO LIQUIDS (TONNE GHG/TJ NATURAL GAS INPUT)</b>			
<b>1B1civ</b>	Gas to liquids	12.73	ND	ND
	<b>OIL TRANSPORT (TONNE/ 10<sup>3</sup>M<sup>3</sup> OIL LOADED ONTO TANKER SHIPS)</b>			
<b>1.B.2.a.i</b>	LOADING OFF-SHORE PRODUCTION ON TANKER SHIPS – WITHOUT VRU - ALL	ND	0.065	ND
<b>1.B.2.a.i</b>	LOADING OFF-SHORE PRODUCTION ON TANKER SHIPS - WITH VRU - ALL	ND	0.040	ND
<b>1B2a</b>	<b>OIL REFINING (tonnes/ 10<sup>3</sup>M<sup>3</sup> OIL REFINED)</b>			
<b>1.B.2.a.iii.4</b>	ALL <sup>55</sup>	5.85	See Table B.2 <sup>56</sup>	8.77 x 10 <sup>-5</sup>

<sup>55</sup> The factors include fugitive equipment leaks, flaring, storage of crude oil, handling and calcination

<sup>56</sup> Use the 2006 IPCC Guideline value found in Table Table B.2

## Annexure C: Default IPCC Emission Factors for Industrial Processes and Product Use

Table C.1: Default IPCC emissions factors for Industrial Process and Product Use (IPCC 2006)

IPCC Code	Source Category Activity / Raw Material / Product	Tonne CO <sub>2</sub> /tonne product	Tonne CH <sub>4</sub> /tonne product	Tonne N <sub>2</sub> O/tonne product	Tonne C <sub>2</sub> F <sub>6</sub> /tonne product	Tonne CF <sub>4</sub> /tonne product	Tonne SF <sub>6</sub> /tonne product
2A1	<b><i>CEMENT PRODUCTION (PER TONNE OF CLINKER)</i></b>						
	Cement	0.52					
2A2	<b><i>LIME PRODUCTION (PER TONNE OF LIME)</i></b>						
	Quicklime/High Calcium Lime	0.75					
	Dolomitic Lime	0.77					
	Hydrated Lime	0.59					
2A3	<b><i>GLASS PRODUCTION (PER TONNE GLASS)</i></b>						
	Glass Production	0.2					
2A4	<b><i>OTHER PROCESS USES OF CARBONATES</i></b>						
2A4a	<b><i>CERAMICS (PER TONNE CARBONATE)</i></b>						
	Calcite/Aragonite (CaCO <sub>3</sub> )	0.43971					
	Magnesite (MgCO <sub>3</sub> )	0.52197					
	Dolomite (CaMg(CO <sub>3</sub> ) <sub>2</sub> )	0.47732					
	Siderite (FeCO <sub>3</sub> )	0.37987					
		0.40822					
	Ankerite (Ca(Fe,Mg,Mn)(CO <sub>3</sub> ) <sub>2</sub> )	to					
		0.47572					
	Rhodochrosite (MnCO <sub>3</sub> )	0.38286					
	Sodium Carbonate/Soda Ash (Na <sub>2</sub> CO <sub>3</sub> )	0.41492					
	2A4b	<b><i>OTHER USES OF SODA ASH (PER TONNE CARBONATE)</i></b>					
Calcite/Aragonite (CaCO <sub>3</sub> )		0.43971					
Magnesite (MgCO <sub>3</sub> )		0.52197					
Dolomite (CaMg(CO <sub>3</sub> ) <sub>2</sub> )		0.47732					
Siderite (FeCO <sub>3</sub> )		0.37987					
		0.40822					
Ankerite (Ca(Fe,Mg,Mn)(CO <sub>3</sub> ) <sub>2</sub> )		to					
		0.47572					
Rhodochrosite (MnCO <sub>3</sub> )		0.38286					
Sodium Carbonate/Soda Ash (Na <sub>2</sub> CO <sub>3</sub> )		0.41492					
2A4c		<b><i>NON METALLURGICAL MAGNESIA</i></b>					

IPCC Code	Source Category Activity / Raw Material / Product	Tonne CO <sub>2</sub> /tonne product	Tonne CH <sub>4</sub> /tonne product	Tonne N <sub>2</sub> O/tonne product	Tonne C <sub>2</sub> F <sub>6</sub> /tonne product	Tonne CF <sub>4</sub> /tonne product	Tonne SF <sub>6</sub> /tonne product
	<b>PRODUCTION (PER TONNE CARBONATE)</b>						
	Calcite/Aragonite (CaCO <sub>3</sub> )	0.43971					
	Magnesite (MgCO <sub>3</sub> )	0.52197					
	Dolomite (CaMg(CO <sub>3</sub> ) <sub>2</sub> )	0.47732					
	Siderite (FeCO <sub>3</sub> )	0.37987					
	Ankerite (Ca(Fe,Mg,Mn)(CO <sub>3</sub> ) <sub>2</sub> )	0.40822 to 0.47572					
	Rhodochrosite (MnCO <sub>3</sub> )	0.38286					
	Sodium Carbonate/Soda Ash (Na <sub>2</sub> CO <sub>3</sub> )	0.41492					
2A4d/2A5	<b>OTHER (PER TONNE CARBONATE)</b>						
	Calcite/Aragonite (CaCO <sub>3</sub> )	0.43971					
	Magnesite (MgCO <sub>3</sub> )	0.52197					
	Dolomite (CaMg(CO <sub>3</sub> ) <sub>2</sub> )	0.47732					
	Siderite (FeCO <sub>3</sub> )	0.37987					
	Ankerite (Ca(Fe,Mg,Mn)(CO <sub>3</sub> ) <sub>2</sub> )	0.40822 to 0.47572					
	Rhodochrosite (MnCO <sub>3</sub> )	0.38286					
	Sodium Carbonate/Soda Ash (Na <sub>2</sub> CO <sub>3</sub> )	0.41492					
2B1	<b>AMMONIA PRODUCTION (PER TONNE NH<sub>3</sub>)</b>						
	Modern Plants-Conventional Reforming (Natural Gas)	1.694					
	Excess Air Reforming (Natural Gas)	1.666					
	Autothermal Reforming (Natural Gas)	1.694					
	Partial Oxidation	2.772					
	Average Value Natural Gas (Mixture Of Modern & Old)	2.104					
	Average Value (Partial Oxidation)	3.273					
2B2	<b>NITRIC ACID PRODUCTION (PER TONNE NITRIC ACID)</b>						
	Plants With Nscr (All Processes)			0.002			
	Plants With Process (Integrated Or Tailgas NO <sub>2</sub> Destruction)			0.0025			
	Atmospheric Pressure Plants (Low Pressure Plants)			0.005			
	Medium Pressure Combustion Plants (Medium Pressure)			0.007			
	High Pressure Plants (High Pressure)			0.009			



IPCC Code	Source Category Activity / Raw Material / Product	Tonne CO <sub>2</sub> /tonne product	Tonne CH <sub>4</sub> /tonne product	Tonne N <sub>2</sub> O/tonne product	Tonne C <sub>2</sub> F <sub>6</sub> /tonne product	Tonne CF <sub>4</sub> /tonne product	Tonne SF <sub>6</sub> /tonne product
2B3	<b>ADIPIC ACID PRODUCTION (PER TONNE ADIPIC ACID UNCONTROLLED)</b>						
	Nitric Acid Oxidation (Adipic Acid)			0.3			
2B4	<b>CAPROLACTAM, GLYOXAL AND GLYOXYLIC ACID PRODUCTION (PER TONNE PRODUCED)</b>						
	Caprolactam Production (Raschig)			0.009			
	Glyoxal Production			0.1			
	Glyoxylic Acid Production			0.02			
2B5	<b>CARBIDE PRODUCTION (PER TONNE RAW MATERIAL USED)</b>						
	Silicon Carbide Production	2.3	0.0102				
	Petroleum Coke Use (Calcium Carbide Production)	1.7					
2B5	<b>CARBIDE PRODUCTION (PER TONNE CARBIDE PRODUCED)</b>						
	Silicon Carbide Production (Carbide Produced)	2.62	0.0116				
	Petroleum Coke Use (Calcium Carbide Produced)	1.09					
	Use Of Product	1.1					
2B6	<b>TITANIUM DIOXIDE PRODUCTION (PER TONNE PRODUCT)</b>						
	Titanium Slag	Not Available					
	Synthetic Rutile	1.43					
	Rutile Titanium Dioxide (Chloride Route)	1.34					
2B7	<b>SODA ASH PRODUCTION (PER TONNE OF SODA ASH OR TRONA)</b>						
	Natural Soda Ash Output	0.138					
	Natural Soda Ash (Trona Used)	0.097					
2B8	<b>PETROCHEMICAL AND CARBON BLACK PRODUCTION</b>						
2B8a	<b>METHANOL PRODUCTION (PER TONNE METHANOL PRODUCED)</b>						
	Conventional Steam Reforming Without Primary Reformer (Natural Gas Feedstock)	0.67	0.0023				

IPCC Code	Source Category Activity / Raw Material / Product	Tonne CO <sub>2</sub> /tonne product	Tonne CH <sub>4</sub> /tonne product	Tonne N <sub>2</sub> O/tonne product	Tonne C <sub>2</sub> F <sub>6</sub> /tonne product	Tonne CF <sub>4</sub> /tonne product	Tonne SF <sub>6</sub> /tonne product
	Conventional Steam Reforming With Primary Reformer (Natural Gas Feedstock)	0.497	0.0023				
	Conventional Steam Reforming Lurgi Conventional Process (Natural Gas Feedstock)	0.385	0.0023				
	Conventional Steam Reforming Lurgi Conventional Process (Natural Gas+Co2CO <sub>2</sub> Feedstock)	0.267	0.0023				
	Conventional Steam Reforming Lurgi Low Pressure Process (Natural Gas Feedstock)	0.267	0.0023				
	Conventional Steam Reforming Lurgi Combined Process (Natural Gas Feedstock)	0.396	0.0023				
	Conventional Steam Reforming Lurgi Mega Methanol Process (Natural Gas Feedstock)	0.31	0.0023				
	Partial Oxidation Process (Oil Feedstock)	1.376	0.0023				
	Partial Oxidation Process (Coal Feedstock)	5.285	0.0023				
	Partial Oxidation Process (Lignite Feedstock)	5.02	0.0023				
	Conventional Steam Reforming With Integrated Ammonia Production (Natural Gas Feedstock)	1.02	0.0023				
<b>2B8b</b>	<b>STEAM CRACKING ETHYLENE PRODUCTION (PER TONNE ETHYLENE PRODUCED)</b>						
	Ethylene (Total Process & Energy Feedstock Use) - Naptha	1.73	0.003				
	Ethylene (Total Process & Energy Feedstock Use) - Gas Oil	2.29	0.003				
	Ethylene (Total Process & Energy Feedstock Use) - Ethane	0.95	0.006				
	Ethylene (Total Process & Energy Feedstock Use) - Propane	1.04	0.003				
	Ethylene (Total Process & Energy Feedstock Use) - Butane	1.07	0.003				
	Ethylene (Total Process & Energy Feedstock Use) - Other	1.73	0.003				
	Ethylene ( Process Feedstock Use) - Naphtha	1.73	0.003				
	Ethylene ( Process Feedstock Use) - Gas Oil	2.17	0.003				
	Ethylene ( Process Feedstock Use) - Ethane	0.76	0.006				
	Ethylene ( Process Feedstock Use) - Propane	1.04	0.003				
	Ethylene ( Process Feedstock Use) - Butane	1.07	0.003				
	Ethylene ( Process Feedstock Use) -Other	1.73	0.003				

IPCC Code	Source Category Activity / Raw Material / Product	Tonne CO <sub>2</sub> /tonne product	Tonne CH <sub>4</sub> /tonne product	Tonne N <sub>2</sub> O/tonne product	Tonne C <sub>2</sub> F <sub>6</sub> /tonne product	Tonne CF <sub>4</sub> /tonne product	Tonne SF <sub>6</sub> /tonne product
	Ethylene ( Supplemental Fuel-Energy Feedstock) Use - Gas Oil	0.12	0.003				
	Ethylene ( Supplemental Fuel-Energy Feedstock) Use - Ethane	0.19	0.006				
2B8c	<b>ETHYLENE DICHLORIDE AND VINYL CHLORIDE MONOMER (PER TONNE EDC PRODUCED OR TONNE VCM PRODUCT PRODUCED)</b>						
	Direct Chlorination Process (EDC)	0.191	0.0000226				
	Oxychlorination Process (EDC)	0.202	0.0000226				
	Balanced Process (Default) - EDC	0.196	0.0000226				
2B8c	<b>ETHYLENE DICHLORIDE AND VINYL CHLORIDE MONOMER (PER TONNE VCM PRODUCED OR TONNE VCM PRODUCT PRODUCED)</b>						
	Direct Chlorination-Process (VCM)	0.286	0.0000226				
	Oxychlorination Process (VCM)	0.302	0.0000226				
	Balanced Process (Default) - VCM	0.294	0.0000226				
2B8d	<b>ETHYLENE OXIDE (PER TONNE ETHYLENE OXIDE PRODUCED)</b>						
	Air Process (Default) - Catalyst Default (70)	0.863	0.00179				
	Air Process (Default) - Catalyst (75)	0.663	0.00179				
	Air Process (Default) - Catalyst (80)	0.5	0.00179				
	Oxygen Process (Default) - Catalyst Default (75)	0.663	0.00179				
	Oxygen Process - Catalyst (80)	0.5	0.00179				
	Oxygen Process - Catalyst (85)	0.35	0.00179				
	All Ethylene Oxide Processes - Thermal Treatment	NA	0.00079				
2B8e	<b>ACRYLONITRILE (PER TONNE ACRYLONITRILE PRODUCED)</b>						
	Direct Ammoxidation With Secondary Products Burned For Energy Recovery Or Flared (Default)	1	0.00018				
	Direct Ammoxidation With Acetonitrile Burned For Energy Recovery Or Flared	0.83	0.00018				

IPCC Code	Source Category Activity / Raw Material / Product	Tonne CO <sub>2</sub> /tonne product	Tonne CH <sub>4</sub> /tonne product	Tonne N <sub>2</sub> O/tonne product	Tonne C <sub>2</sub> F <sub>6</sub> /tonne product	Tonne CF <sub>4</sub> /tonne product	Tonne SF <sub>6</sub> /tonne product
	Direct Ammoxidation With Acetonitrile & Hydrogen Cyanide Recovered As Product	0.79	0.00018				
<b>2B8f</b>	<b>CARBON BLACK PRODUCTION (PER TONNE CARBON BLACK PRODUCED)</b>						
	Furnace Black Process (Default) - Primary Feedstock	1.96	0.00006				
	Thermal Black Process - Primary Feedstock	4.59	0.00006				
	Acetylene Black Process - Primary Feedstock	0.12	0.00006				
	Furnace Black Process (Default) - Secondary Feedstock	0.66	0.00006				
	Thermal Black Process - Secondary Feedstock	0.66	0.00006				
	Acetylene Black Process - Secondary Feedstock	0.66	0.00006				
	Furnace Black Process (Default) - Total Feedstock	2.62	0.00006				
	Thermal Black Process - Total Feedstock	5.25	0.00006				
	Acetylene Black Process - Total Feedstock	0.78	0.00006				
	All Carbon Black Processes (No Thermal Treatment)	NA	0.0287				
<b>2C1</b>	<b>IRON AND STEEL PRODUCTION (PER TONNE PRODUCT PRODUCED)</b>						
	Sinter Production	0.2	0.00007				
	Coke Oven	0.56	0.0000001				
	Pig Iron Production	1.35					
	Direct Reduced Iron (DRI) Production	0.7	0.001/TJ (NG)				
	Pellet Production	0.03					
	Basic Oxygen Furnace	1.46					
	Electric Arc Furnace	0.08					
	Open Hearth Furnace	1.72					
	Global Average	1.06					
<b>2C2</b>	<b>FERROALLOYS PRODUCTION (PER TONNE PRODUCTION)</b>						
	Ferrosilicon (45% Si)	2.5					
	Ferrosilicon (65% Si)	3.6	0.001				
	Ferrosilicon (75% Si)	4	0.001				
	Ferrosilicon (90% Si)	4.8	0.0011				
	Ferromanganese (7% C)	1.3					
	Ferromanganese (1% C)	1.5					
	Silicomanganese	1.4					
	Silicon Metal	5	0.0012				

IPCC Code	Source Category Activity / Raw Material / Product	Tonne CO <sub>2</sub> /tonne product	Tonne CH <sub>4</sub> /tonne product	Tonne N <sub>2</sub> O/tonne product	Tonne C <sub>2</sub> F <sub>6</sub> /tonne product	Tonne CF <sub>4</sub> /tonne product	Tonne SF <sub>6</sub> /tonne product
	Ferrochromium (Stand Alone)	1.3					
	Ferrochromium (With Sinter Plant)	1.6					
2C3	<b>ALUMINIUM PRODUCTION (PER TONNE ALUMINIUM PRODUCED)</b>						
	Prebake	1.6					
	Soderberg	1.7					
	CWPB				0.00004	0.0004	
	SWPB				0.0004	0.0016	
	VSS				0.00004	0.0008	
	HSS				0.00003	0.0004	
2C4	<b>MAGNESIUM PRODUCTION (PER TONNE MAGNESIUM PRODUCED)</b>						
	Dolomite	5.13					0.001
	Magnesite	2.83					0.001
2C5	<b>LEAD PRODUCTION (PER TONNE PRODUCT)</b>						
	Imperial Smelt Furnace (ISF) Production	0.59					
	Direct Smelting Production	0.25					
	Treatment Of Secondary Raw Materials	0.2					
	Default EF	0.52					
2C6	<b>ZINC PRODUCTION (PER TONNE PRODUCT)</b>						
	Waelz Kiln	3.66					
	Pyrometallurgical	0.43					
	Default EF	1.72					

## Annexure D: Country-specific Net Caloric Values of fuels

The net calorific values for liquid, gaseous and solid fuels are provided in the table below.

Table D.1: Net calorific values for liquid, gaseous and solid fuels (provided by the South African Petroleum Industry Association and from the 2022 Liquid & Gas Fuel Study and 2022 Cement Study)

	Fuel	Net Calorific Value	Unit	Density (kg/l)
<b>Liquid fuels</b>	Paraffin	37.5	MJ/l	0.765
	Diesel <sup>57</sup>	35.5	MJ/l	0.8255
	Heavy Fuel Oil	43	MJ/kg	0.994
	Fuel Oil 180	42	MJ/kg	0.99
	Petrol <sup>57</sup>	32.5	MJ/l	0.7405
	Avgas (100LL)	33.9	MJ/l	0.714
	Jet Fuel (Jet-A1)	37.5	MJ/l	0.79
	Jet Kerosene <sup>57</sup>	34.4	MJ/l	0.794
	Polyfuel <sup>58</sup>	44.2	MJ/kg	0.8
<b>Gaseous fuels</b>	LPG <sup>57</sup>	46.29	MJ/kg	0.555
	Sasol Gas (MRG)	33.6	MJ/Nm <sup>3</sup>	
	Natural Gas	38.1	MJ/Nm <sup>3</sup>	
	Blast furnace gas	3.1	MJ/Nm <sup>3</sup>	
	Refinery gas	20	MJ/Nm <sup>3</sup>	
	Coke oven gas	17.3	MJ/Nm <sup>3</sup>	
<b>Solid fuels</b>	Bagasse	6.7 <sup>58</sup>	MJ/kg	
	Coal Power Generation Average	19. <sup>2958</sup>	MJ/kg	
	Coal General Purpose	24.3	MJ/kg	
	Coal (coking)	30.1	MJ/kg	
	Coke	27.9	MJ/kg	
	Biomass (wood dry typical)	17	MJ/kg	
	Wood Charcoal	31	MJ/kg	16
	Waste Tyres <sup>59</sup>	33.7	MJ/kg	
Sawdust <sup>59</sup>	14.6	MJ/kg		
Refuse derived Fuel	23.8	MJ/kg		

<sup>57</sup> Based on the data from the Development of Country-Specific CO<sub>2</sub> Emission Factors for Liquid and Gaseous Fuels in South Africa study report, 2022

<sup>58</sup> The Data is based on Latest SAGERS system. If new data comes and the value needs to be corrected, please use SAGERS system for the latest number. SAGERS system will always be pre-populated with country specific NCV values in every reporting period. As new and improved values become available, the NCVs will be updated within SAGERS every reporting period, therefore SAGERS will always have the latest and newest value.

## Annexure E: Basic information on Units

### Prefixes and multiplication factors

Multiplication Factor	Abbreviation	Prefix	Symbol
1 000 000 000 000 000	10 <sup>15</sup>	peta	<b>P</b>
1 000 000 000 000	10 <sup>12</sup>	tera	<b>T</b>
1 000 000 000	10 <sup>9</sup>	giga	<b>G</b>
1 000 000	10 <sup>6</sup>	mega	<b>M</b>
1 000	10 <sup>3</sup>	kilo	<b>k</b>
100	10 <sup>2</sup>	hecto	<b>h</b>
10	10 <sup>1</sup>	deca	<b>da</b>
0.1	10 <sup>-1</sup>	deci	<b>d</b>
0.01	10 <sup>-2</sup>	centi	<b>c</b>
0.001	10 <sup>-3</sup>	milli	<b>m</b>
0.000 001	10 <sup>-6</sup>	micro	<b>µ</b>

### Units and abbreviations

Cubic metre	m <sup>3</sup>
Gram	g
Tonne	t
Joule	J
Year	yr
Dry Matter	dm

### Standard Equivalents

1 tonne of oil equivalent (toe)	1 x 10 <sup>10</sup> calories
10 <sup>3</sup> toe	41.868 TJ
1 short ton	0.9072 tonne
1 tonne	1.1023 short tons
1 tonne	1 megagram
1 kilotonne	1 gigagram
1 megatonne	1 teragram
1 gigatonne	1 petagram
1 kilogram	2.2046 lbs
1 hectare	10 <sup>4</sup> m <sup>2</sup>
1 calorie	4.1868 Joules
1 atmosphere	101.325 kPa

## Annexure F: IPCC Source Codes and Definitions (GHG Activities listed in Annexure 1 of the National Greenhouse Gas Emissions Reporting Regulations (DEA 2016))

**Table F.1:** IPCC source codes and definitions

IPCC Source Codes (GHG Activities in terms of Annexure 1 of the Reporting Regulations)	Name	Definition
1	<b>ENERGY</b>	This category includes all GHG emissions arising from combustion and fugitive releases of fuels. Emissions from the non-energy uses of fuels are generally not included here, but reported under Industrial Processes and Product Use Sector.
1 A	<b>Fuel Combustion Activities</b>	Emissions from the intentional oxidation of materials within an apparatus that is designed to raise heat and provide it either as heat or as mechanical work to a process or for use away from the apparatus.
1 A 1	<i>Energy Industries</i>	Comprises emissions from fuels combusted by the fuel extraction or energy-producing industries.
1 A 1 a	Main Activity Electricity and Heat Production	Sum of emissions from main activity producers of electricity generation, combined heat and power generation, and heat plants. Main activity producers (formerly known as public utilities) are defined as those undertakings whose primary activity is to supply the public. They may be in public or private ownership. Emissions from own on-site use of fuel should be included. Emissions from auto producers (undertakings which generate electricity/heat wholly or partly for their own use, as an activity that supports their primary activity) should be assigned to the sector where they were generated and not under 1 A 1 a. Auto producers may be in public or private ownership.
1 A 1 a i	<i>Electricity Generation</i>	Comprises emissions from all fuel use for electricity generation from main activity producers except those from combined heat and power plants.
1 A 1 a ii	<i>Combined Heat and Power Generation (CHP)</i>	Emissions from production of both heat and electrical power from main activity producers for sale to the public, at a single CHP facility.
1 A 1 a iii	<i>Heat Plants</i>	Production of heat from main activity producers for sale by pipe network.
1 A 1 b	Petroleum Refining	All combustion activities supporting the refining of petroleum products including on-site combustion for the generation of electricity and heat for own use. Does not include evaporative emissions occurring at the refinery. These emissions should be reported separately under 1 B 2 a.
1 A 1 c	Manufacture of Solid Fuels and Other Energy Industries	Combustion emissions from fuel use during the manufacture of secondary and tertiary products from solid fuels including production of charcoal. Emissions from own on-site fuel use should be included. Also includes combustion for the generation of electricity and heat for own use in these industries.
1 A 1 c i	<i>Manufacture of Solid Fuels</i>	Emissions arising from fuel combustion for the production of coke, brown coal briquettes and patent fuel.
1 A 1 c ii	<i>Other Energy Industries</i>	Combustion emissions arising from the energy-producing industries own (on-site) energy use not mentioned above or for which separate data are not available. This includes the emissions from own-energy use for the production of charcoal, bagasse, saw dust, cotton stalks and carbonizing of biofuels as well as fuel used for coal mining, oil and gas extraction and the processing and upgrading of natural gas. This category also includes emissions from pre-combustion processing



IPCC Source Codes (GHG Activities in terms of Annexure 1 of the Reporting Regulations)				Name	Definition
					for CO <sub>2</sub> capture and storage. Combustion emissions from pipeline transport should be reported under 1 A 3 e.
1	A	2		<i>Manufacturing Industries and Construction</i>	Emissions from combustion of fuels in industry. Also includes combustion for the generation of electricity and heat for own use in these industries. Emissions from fuel combustion in coke ovens within the iron and steel industry should be reported under 1 A 1 c and not within manufacturing industry. Emissions from the industry sector should be specified by sub-categories that correspond to the International Standard Industrial Classification of all Economic Activities (ISIC). Energy used for transport by industry should not be reported here but under Transport (1 A 3). Emissions arising from off-road and other mobile machinery in industry should, if possible, be broken out as a separate subcategory. For each country, the emissions from the largest fuel-consuming industrial categories ISIC should be reported, as well as those from significant emitters of pollutants. A suggested list of categories is outlined below.
1	A	2	a	Iron and Steel	ISIC Group 271 and Class 2731.
1	A	2	b	Non-Ferrous Metals	ISIC Group 272 and Class 2732.
1	A	2	c	Chemicals	ISIC Division 24.
1	A	2	d	Pulp, Paper and Print	ISIC Divisions 21 and 22.
1	A	2	e	Food Processing, Beverages and Tobacco	ISIC Divisions 15 and 16.
1	A	2	f	Non-Metallic Minerals	Includes products such as glass ceramic, cement, etc. ISIC Division 26.
1	A	2	g	Transport Equipment	ISIC Divisions 34 and 35.
1	A	2	h	Machinery	Includes fabricated metal products, machinery and equipment other than transport equipment. ISIC Divisions 28, 29, 30, 31 and 32.
1	A	2	i	Mining (excluding fuels) and Quarrying	ISIC Divisions 13 and 14.
1	A	2	j	Wood and Wood Products	ISIC Division 20.
1	A	2	k	Construction	ISIC Division 45.
1	A	2	l	Textile and Leather	ISIC Divisions 17, 18 and 19.
1	A	2	m	Brick Manufacturing	Any manufacturing industry/construction not included above or for which separate data are not available. Includes ISIC Divisions 25, 33, 36 and 37.
1	A	2	n	Manufacture of ceramic products by firing, in particular roofing tiles, tiles, stoneware or porcelain	Manufacture of refractory ceramic goods, see ISIC Code - 2391
1	A	3		<i>Transport</i>	Emissions from the combustion and evaporation of fuel for all transport activity (excluding military transport), regardless of the sector, specified by sub-categories below. Emissions from fuel sold to any air or marine vessel engaged in international transport (1 A 3 a i and 1 A 3 d i) should as far as possible be excluded from the totals and subtotals in this category and should be reported separately.

IPCC Source Codes (GHG Activities in terms of Annexure 1 of the Reporting Regulations)	Name	Definition
1 A 3 a	Civil Aviation	Emissions from international and domestic civil aviation, including take-offs and landings. Comprises civil commercial use of airplanes, including: scheduled and charter traffic for passengers and freight, air taxiing, and general aviation. The international/domestic split should be determined on the basis of departure and landing locations for each flight stage and not by the nationality of the airline. Exclude use of fuel at airports for ground transport which is reported under 1 A 3 e Other Transportation. Also exclude fuel for stationary combustion at airports; report this information under the appropriate stationary combustion category.
1 A 3 a i	<i>International Aviation (International Bunkers)</i>	Emissions from flights that depart in one country and arrive in a different country. Include take-offs and landings for these flight stages. Emissions from international military aviation can be included as a separate sub-category of international aviation provided that the same definitional distinction is applied and data are available to support the definition.
1 A 3 a ii	<i>Domestic Aviation</i>	Emissions from civil domestic passenger and freight traffic that departs and arrives in the same country (commercial, private, agriculture, etc.), including take-offs and landings for these flight stages. Note that this may include journeys of considerable length between two airports in a country (e.g. San Francisco to Honolulu). Exclude military, which should be reported under 1 A 5 b.
1 A 3 b	Road Transportation	All combustion and evaporative emissions arising from fuel use in road vehicles, including the use of agricultural vehicles on paved roads.
1 A 3 b i	<i>Cars</i>	Emissions from automobiles so designated in the vehicle registering country primarily for transport of persons and normally having a capacity of 12 persons or fewer.
1 A 3 b i 1	Passenger Cars With 3-way Catalysts	Emissions from passenger car vehicles with 3-way catalysts.
1 A 3 b i 2	Passenger Cars Without 3-way Catalysts	Passenger car emissions from vehicles without 3-way catalysts.
1 A 3 b ii	<i>Light-duty Trucks</i>	Emissions from vehicles so designated in the vehicle registering country primarily for transportation of light-weight cargo or which are equipped with special features such as four-wheel drive for off-road operation. The gross vehicle weight normally ranges up to 3500-3900 kg or less.
1 A 3 b ii 1	Light-duty Trucks With 3-way Catalysts	Emissions from light duty trucks with 3-way catalysts.
1 A 3 b ii 2	Light-duty Trucks Without 3-way Catalysts	Emissions from light duty trucks without 3-way catalysts.
1 A 3 b iii	<i>Heavy-duty Trucks and Buses</i>	Emissions from any vehicles so designated in the vehicle registering country. Normally the gross vehicle weight ranges from 3500-3900 kg or more for heavy duty trucks and the buses are rated to carry more than 12 persons.
1 A 3 b iv	<i>Motorcycles</i>	Emissions from any motor vehicle designed to travel with not more than three wheels in contact with the ground and weighing less than 680 kg.
1 A 3 b v	<i>Evaporative Emissions from Vehicles</i>	Evaporative emissions from vehicles (e.g. hot soak, running losses) are included here. Emissions from loading fuel into vehicles are excluded.
1 A 3 b vi	<i>Urea-based Catalysts</i>	CO <sub>2</sub> emissions from use of urea-based additives in catalytic converters (non-combustive emissions).
1 A 3 c	Railways	Emissions from railway transport for both freight and passenger traffic routes.
1 A 3 d	Water-borne Navigation	Emissions from fuels used to propel water-borne vessels, including hovercraft and hydrofoils, but <b>excluding fishing vessels</b> . The international/domestic

IPCC Source Codes (GHG Activities in terms of Annexure 1 of the Reporting Regulations)				Name	Definition
					split should be determined on the basis of port of departure and port of arrival, and not by the flag or nationality of the ship.
1	A	3	d i	<i>International Water-borne Navigation (International Bunkers)</i>	Emissions from fuels used by vessels of all flags that are engaged in international water-borne navigation. The international navigation may take place at sea, on inland lakes and waterways and in coastal waters. Includes emissions from journeys that depart in one country and arrive in a different country. Including fishing and shipping vessels. Please note that the definition from the IPCC excludes consumption by fishing vessels. DFFE has included consumption by fishing and shipping vessels to aid with our local reporting. Emissions from international military water-borne navigation can be included as a separate sub-category of international water-borne navigation provided that the same definitional distinction is applied and data are available to support the definition.
1	A	3	d ii	<i>Domestic Water-borne Navigation</i>	Emissions from fuels used by vessels of all flags that depart and arrive in the same country (including fishing and shipping vessels). Please note that the definition from the IPCC excludes consumption by fishing vessels. DFFE has included consumption by fishing and shipping vessels to aid with our local reporting. Note that this may include journeys of considerable length between two ports in a country (e.g. San Francisco to Honolulu).
1	A	3	e	Other Transportation	Combustion emissions from all remaining transport activities including pipeline transportation, ground activities in airports and harbours, and off-road activities not otherwise reported under 1 A 4 c Agriculture or 1 A 2. Manufacturing Industries and Construction. Military transport should be reported under 1 A 5 (see 1 A 5 Non-specified).
1	A	3	e i	<i>Pipeline Transport</i>	Combustion related emissions from the operation of pump stations and maintenance of pipelines. Transport via pipelines includes transport of gases, liquids, slurry and other commodities via pipelines. Distribution of natural or manufactured gas, water or steam from the distributor to final users is excluded and should be reported in 1 A 1 c ii or 1 A 4 a.
1	A	3	e ii	<i>Off-road</i>	Combustion emissions from Other Transportation excluding Pipeline Transport.
1	A	4		<i>Other Sectors</i>	Emissions from combustion activities as described below, including combustion for the generation of electricity and heat for own use in these sectors.
1	A	4	a	Commercial/Institutional	Emissions from fuel combustion in commercial and institutional buildings; all activities included in ISIC Divisions 41,50, 51, 52, 55, 63-67, 70-75, 80, 85, 90-93 and 99.
1	A	4	b	Residential	All emissions from fuel combustion in households.
1	A	4	c	Agriculture/Forestry/Fishing/Fish Farms	Emissions from fuel combustion in agriculture, forestry, fishing and fishing industries such as fish farms. Activities included in ISIC Divisions 01, 02 and 05. Highway agricultural transportation is excluded.
1	A	4	c i	<i>Stationary</i>	Emissions from fuels combusted in pumps, grain drying, horticultural greenhouses and other agriculture, forestry or stationary combustion in the fishing industry.
1	A	4	c ii	<i>Off-road Vehicles and Other Machinery</i>	Emissions from fuels combusted in traction vehicles on farm land and in forests.
1	A	4	c iii	<i>Fishing (stationary combustion)</i>	Emissions from fuels combusted for inland, coastal and deep-sea fishing. Fishing should cover vessels of all flags that have refuelled in the country (include international fishing). Please note that DFFE has assigned this code

IPCC Source Codes (GHG Activities in terms of Annexure 1 of the Reporting Regulations)	Name	Definition
		to stationary activities related to fishing (e.g. any fish processing activities onsite or onboard) to aid with local reporting.
1 A 5	<i>Non-Specified</i>	All remaining emissions from fuel combustion that are not specified elsewhere. Include emissions from fuel delivered to the military in the country and delivered to the military of other countries that are not engaged in multilateral operations. Emissions from fuel sold to any air or marine vessel engaged in multilateral operation pursuant to the Charter of the United Nations should be excluded from the totals and subtotals of the military transport, and should be reported separately.
1 A 5 a	Stationary	Emissions from fuel combustion in stationary sources that are not specified elsewhere.
1 A 5 b	Mobile	Emissions from vehicles and other machinery, marine and aviation (not included in 1 A 4 c ii or elsewhere).
1 A 5 b i	<i>Mobile (Aviation Component)</i>	All remaining aviation emissions from fuel combustion that are not specified elsewhere. Include emissions from fuel delivered to the country's military not otherwise included separately in 1 A 3 a i as well as fuel delivered within that country but used by militaries of other countries that are not engaged in multilateral operation pursuant to the Charter of the United Nations.
1 A 5 b ii	<i>Mobile (Water-borne Component)</i>	All remaining water-borne emissions from fuel combustion that are not specified elsewhere. Include emissions from fuel delivered to the country's military not otherwise included separately in 1 A 3 d i as well as fuel delivered within that country but used by militaries of other countries that are not engaged in multilateral operation pursuant to the Charter of the United Nations.
1 A 5 b iii	<i>Mobile (Other)</i>	All remaining emissions from mobile sources not included elsewhere.
1 A 5 c	Multilateral Operations	Emissions from fuel sold to any air or marine vessel engaged in multilateral operations pursuant to the Charter of the United Nations should be excluded from the totals and subtotals of the military transport, and should be reported separately.
1 B	<b>Fugitive Emissions from Fuels</b>	Includes all intentional and unintentional emissions from the extraction, processing, storage and transport of fuel to the point of final use.
1 B 1	<i>Solid Fuels</i>	Includes all intentional and unintentional emissions from the extraction, processing, storage and transport of fuel to the point of final use.
1 B 1 a	Coal Mining and Handling	Includes all fugitive emissions from coal.
1 B 1 a i	<i>Underground Mines</i>	Includes all emissions arising from mining, post-mining, abandoned mines and flaring of drained methane.
1 B 1 a i 1	Mining	Includes all seam gas emissions vented to atmosphere from coal mine ventilation air and degasification systems.
1 B 1 a i 2	Post-mining Seam Gas Emissions	Includes methane and CO <sub>2</sub> emitted after coal has been mined, brought to the surface and subsequently processed, stored and transported.
1 B 1 a i 3	Abandoned Underground Mines	Includes methane emissions from abandoned underground mines.
1 B 1 a i 4	Flaring of Drained Methane or Conversion of Methane to CO <sub>2</sub>	Methane drained and flared, or ventilation gas converted to CO <sub>2</sub> by an oxidation process should be included here. Methane used for energy production should be included in Volume 2, Energy, Chapter 2 'Stationary Combustion'.
1 B 1 a ii	<i>Surface Mines</i>	Includes all seam gas emissions arising from surface coal mining.

IPCC Source Codes (GHG Activities in terms of Annexure 1 of the Reporting Regulations)						Name	Definition
1	B	1	a	ii	1	Mining	Includes methane and CO <sub>2</sub> emitted during mining from breakage of coal and associated strata and leakage from the pit floor and high wall.
1	B	1	a	ii	2	Post-mining Seam Gas Emissions	Includes methane and CO <sub>2</sub> emitted after coal has been mined, subsequently processed, stored and transported.
1	B	1	b			<b>Uncontrolled Combustion, and Burning Coal Dumps</b>	Includes fugitive emissions of CO <sub>2</sub> from uncontrolled combustion in coal.
1	B	1	c			Solid Fuel Transformation	Fugitive emissions arising during the manufacture of secondary and tertiary products from solid fuels.
1	B	1	c	i		<i>Coke Production</i>	Fugitive emissions arising from the production of coke.
1	B	1	c	ii		<i>Charcoal and Biochar Production</i>	Fugitive emissions arising from the production of charcoal and biochar.
1	B	1	c	iii		<i>Coal to Liquids</i>	Fugitive emissions arising from the production of liquids from coal.
1	B	2				<i>Oil and Natural Gas</i>	Comprises fugitive emissions from all oil and natural gas activities. The primary sources of these emissions may include fugitive equipment leaks, evaporation losses, venting, flaring and accidental releases.
1	B	2	a			Oil	Comprises emissions from venting, flaring and all other fugitive sources associated with the exploration, production, transmission, upgrading, and refining of crude oil and distribution of crude oil products.
1	B	2	a	i		<i>Venting</i>	Emissions from venting of associated gas and waste gas/vapour streams at oil facilities.
1	B	2	a	ii		<i>Flaring</i>	Emissions from flaring of natural gas and waste gas/vapour streams at oil facilities.
1	B	2	a	iii		<i>All Other</i>	Fugitive emissions at oil facilities from equipment leaks, storage losses, pipeline breaks, well blowouts, land farms, gas migration to the surface around the outside of wellhead casing, surface casing vent bows, biogenic gas formation from tailings ponds and any other gas or vapour releases not specifically accounted for as venting or flaring.
1	B	2	a	iii	I	Exploration	Fugitive emissions (excluding venting and flaring) from oil well drilling, drill stem testing, and well completions.
1	B	2	a	iii	2	Production and Upgrading	Fugitive emissions from oil production (excluding venting and flaring) occur at the oil wellhead or at the oil sands or shale oil mine through to the start of the oil transmission system. This includes fugitive emissions related to well servicing, oil sands or shale oil mining, transport of untreated production (i.e., well effluent, emulsion, oil shale and oil sands) to treating or extraction facilities, activities at extraction and upgrading facilities, associated gas re-injection systems and produced water disposal systems. Fugitive emission from upgraders are grouped with those from production rather than those from refining since the upgraders are often integrated with extraction facilities and their relative emission contributions are difficult to establish. However, upgraders may also be integrated with refineries, co-generation plants or other industrial facilities and their relative emission contributions can be difficult to establish in these cases.
1	B	2	a	iii	3	Transport	Fugitive emissions (excluding venting and flaring) related to the transport of marketable crude oil (including conventional, heavy and synthetic crude oil and bitumen) to upgraders and refineries. The transportation systems may comprise pipelines, marine tankers, tank trucks and rail cars. Evaporation losses from storage, filling and unloading activities and fugitive

IPCC Source Codes (GHG Activities in terms of Annexure 1 of the Reporting Regulations)						Name	Definition
							equipment leaks are the primary sources of these emissions.
1	B	2	a	iii	4	Refining	Fugitive emissions (excluding venting and flaring) at petroleum refineries. Refineries process crude oils, natural gas liquids and synthetic crude oils to produce final refined products (e.g., primarily fuels and lubricants). Where refineries are integrated with other facilities (for example, upgraders or co-generation plants) their relative emission contributions can be difficult to establish.
1	B	2	a	iii	5	Distribution of Oil Products	This comprises fugitive emissions (excluding venting and flaring) from the transport and distribution of refined products, including those at bulk terminals and retail facilities. Evaporation losses from storage, filling and unloading activities and fugitive equipment leaks are the primary sources of these emissions.
1	B	2	a	iii	6	Other	Fugitive emissions from oil systems (excluding venting and flaring) not otherwise accounted for in the above categories. This includes fugitive emissions from spills and other accidental releases, waste oil treatment facilities and oilfield waste disposal facilities.
1	B	2	b			Natural Gas	Comprises emissions from venting, flaring and all other fugitive sources associated with the exploration, production, processing, transmission, storage and distribution of natural gas (including both associated and non-associated gas).
1	B	2	b	i		Venting	Emissions from venting of natural gas and waste gas/vapour streams at gas facilities.
1	B	2	b	ii		Flaring	Emissions from flaring of natural gas and waste gas/vapour streams at gas facilities.
1	B	2	b	iii		All Other	Fugitive emissions at natural gas facilities from equipment leaks, storage losses, pipeline breaks, well blowouts, gas migration to the surface around the outside of wellhead casing, surface casing vent bows and any other gas or vapour releases not specifically accounted for as venting or flaring.
1	B	2	b	iii	1	Exploration	Fugitive emissions (excluding venting and flaring) from gas well drilling, drill stem testing and well completions.
1	B	2	b	iii	2	Production	Fugitive emissions (excluding venting and flaring) from the gas wellhead through to the inlet of gas processing plants, or, where processing is not required, to the tie-in points on gas transmission systems. This includes fugitive emissions related to well servicing, gas gathering, processing and associated waste water and acid gas disposal activities.
1	B	2	b	iii	3	Processing	Fugitive emissions (excluding venting and flaring) from gas processing facilities.
1	B	2	b	iii	4	Transmission and Storage	Fugitive emissions from systems used to transport processed natural gas to market (i.e., to industrial consumers and natural gas distribution systems). Fugitive emissions from natural gas storage systems should also be included in this category. Emissions from natural gas liquids extraction plants on gas transmission systems should be reported as part of natural gas processing (Sector 1.B.2.b.iii.3). Fugitive emissions related to the transmission of natural gas liquids should be reported under Category 1.B.2.a.iii.3.
1	B	2	b	iii	5	Distribution	Fugitive emissions (excluding venting and flaring) from the distribution of natural gas to end users.

IPCC Source Codes (GHG Activities in terms of Annexure 1 of the Reporting Regulations)				Name	Definition
1	B	2	b iii 6	Other	Fugitive emissions from natural gas systems (excluding venting and flaring) not otherwise accounted for in the above categories. This may include emissions from well blowouts and pipeline ruptures or dig-ins.
1	B	3		<i>Other Emissions from Energy Production</i>	Other fugitive emissions for example, from geo thermal energy production, peat and other energy production not included in 1.B.2.
1	C			<b>Carbon Dioxide Transport and Storage</b>	Carbon dioxide (CO <sub>2</sub> ) capture and storage (CCS) involves the capture of CO <sub>2</sub> from anthropogenic sources, its transport to a storage location and its long-term isolation from the atmosphere. Emissions associated with CO <sub>2</sub> transport, injection and storage are covered under category 1C. Emissions (and reductions) associated with CO <sub>2</sub> capture should be reported under the IPCC Sector in which capture takes place (e.g. Fuel Combustion or Industrial Activities).
1	C	1		<i>Transport of CO<sub>2</sub></i>	This comprises fugitive emissions from the systems used to transport captured CO <sub>2</sub> from the source to the injection site. These emissions may comprise losses due to fugitive equipment leaks, venting and releases due to pipeline ruptures or other accidental releases (e.g., temporary storage).
1	C	1	a	Pipelines	Fugitive emissions from the pipeline system used to transport CO <sub>2</sub> to the injection site.
1	C	1	b	Ships	Fugitive emissions from the ships used to transport CO <sub>2</sub> to the injection site.
1	C	1	c	Other (please specify)	Fugitive emissions from other systems used to transport CO <sub>2</sub> to the injection site and temporary storage
1	C	2		<i>Injection and Storage</i>	Fugitive emissions from activities and equipment at the injection site and those from the end containment once the CO <sub>2</sub> is placed in storage.
1	C	2	a	Injection	Fugitive emissions from activities and equipment at the injection site.
1	C	2	b	Storage	Fugitive emissions from the end equipment once the CO <sub>2</sub> is placed in storage.
1	C	3		<i>Other</i>	Any other emissions from CCS not reported elsewhere.
2				<b>INDUSTRIAL PROCESSES AND PRODUCT USE</b>	Emissions from industrial processes and product use, excluding those related to energy combustion (reported under 1A), extraction, processing and transport of fuels (reported under 1B) and CO <sub>2</sub> transport, injection and storage (reported under 1C).
2	A			<b>Mineral Industry</b>	
2	A	1		<i>Cement Production</i>	Process-related emissions from the production of various types of cement (ISIC: D2694).
2	A	2		<i>Lime Production</i>	Process-related emissions from the production of various types of lime (ISIC: D2694).
2	A	3		<i>Glass Production</i>	Process-related emissions from the production of various types of glass (ISIC: D2610).
2	A	4		<i>Other Process Uses of Carbonates</i>	Includes limestone, dolomite and other carbonates etc. Emissions from the use of limestone, dolomite and other carbonates should be included in the industrial source category where they are emitted. Therefore, for example, where a carbonate is used as a flux for iron and steel production, resultant emissions should be reported under 2C1 "Iron and Steel Production" rather than this subcategory.
2	A	4	a	Ceramics	Process-related emissions from the production of bricks and roof tiles, vitrified clay pipes, refractory products, expanded clay products, wall and floor tiles, table and ornamental ware (household ceramics), sanitary ware, technical ceramics, and inorganic bonded abrasives (ISIC: D2691, D2692 and D2693).

IPCC Source Codes (GHG Activities in terms of Annexure 1 of the Reporting Regulations)	Name	Definition
2 A 4 b	Other Uses of Soda Ash	This should include emissions from soda ash use that are not included elsewhere. For example, soda ash used for glass should be reported in 2A3.
2 A 4 c	Non Metallurgical Magnesia Production	This source category should include emissions from magnesia production that are not included elsewhere. For example, where magnesia production is used for primary and secondary magnesium production, emissions should be reported in relevant source category in Metals.
2 A 4 d	Other (please specify)	Process-related emissions reported under this sub-category should include all other miscellaneous uses of limestone, dolomite and other carbonates, except from uses already listed in the sub-categories above, and uses as fluxes or slagging agents in the Metals and Chemicals industries, or for the liming of soils and wetlands in Agriculture, Forestry and Other Land Uses (ISIC D269).
2 A 5	Other (please specify)	
2 B	<b>Chemical Industry</b>	
2 B 1	Ammonia Production	Ammonia (NH <sub>3</sub> ) is a major industrial chemical and the most important nitrogenous material produced. Ammonia gas is used directly as a fertilizer, in heat treating, paper pulping, nitric acid and nitrates manufacture, nitric acid ester and nitro compound manufacture, explosives of various types, and as a refrigerant. Amines, amides, and miscellaneous other organic compounds, such as urea, are made from ammonia. The main greenhouse gas emitted from NH <sub>3</sub> production is CO <sub>2</sub> . CO <sub>2</sub> used in the production of urea, a downstream process, should be subtracted from the CO <sub>2</sub> generated and accounted for in the AFOLU Sector.
2 B 2	Nitric Acid Production	Nitric acid is used as a raw material mainly in the manufacture of nitrogenous-based fertiliser. Nitric acid may also be used in the production of adipic acid and explosives (e.g., dynamite), for metal etching and in the processing of ferrous metals. The main greenhouse gas emitted from HNO <sub>3</sub> production is nitrous oxide.
2 B 3	Adipic Acid Production	Adipic acid is used in the manufacture of a large number of products including synthetic fibres, coatings, plastics, urethane foams, elastomers and synthetic lubricants. The production of Nylon 6.6 accounts for the bulk of adipic acid use. The main greenhouse gas emitted from adipic acid production is nitrous oxide.
2 B 4	Caprolactam, Glyoxal and Glyoxylic Acid Production	Most of the annual production of caprolactam (NH(CH <sub>2</sub> ) <sub>5</sub> CO) is consumed as the monomer for nylon-6 fibres and plastics, with a substantial proportion of the fibre used in carpet manufacturing. All commercial processes for the manufacture of caprolactam are based on either toluene or benzene. This subcategory also covers production of glyoxal (ethanedial) and glyoxylic acid production. The main greenhouse gas emitted from this subcategory is nitrous oxide.
2 B 5	Carbide Production	The production of carbide can result in emissions of CO <sub>2</sub> , CH <sub>4</sub> , CO and SO <sub>2</sub> . Silicon carbide is a significant artificial abrasive. It is produced from silica sand or quartz and petroleum coke. Calcium carbide is used in the production of acetylene, in the manufacture of cyanamide (a minor historical use), and as a reductant in electric arc steel furnaces. It is made from calcium carbonate (limestone) and carbon-containing reductant (petroleum coke).



IPCC Source Codes (GHG Activities in terms of Annexure 1 of the Reporting Regulations)	Name	Definition
2 B 6	<i>Titanium Dioxide Production</i>	Titanium dioxide (TiO <sub>2</sub> ) is the most important white pigment. The main use is in paint manufacture followed by paper, plastics, rubber, ceramics, fabrics, floor covering, printing ink, and other miscellaneous uses. <b>The main production process is the chloride route, giving rise to CO<sub>2</sub> emissions that are likely to be significant.</b> This category also includes synthetic rutile production using the Becher process, and titanium slag production, both of which are reduction processes using fossil fuels and resulting in CO <sub>2</sub> emissions. Synthetic rutile is the major input to TiO <sub>2</sub> production using the chloride route.
2 B 7	<i>Soda Ash Production</i>	Soda ash (sodium carbonate, Na <sub>2</sub> CO <sub>3</sub> ) is a white crystalline solid that is used as a <b>raw material in a large number of industries including glass manufacture, soap and detergents, pulp and paper production and water treatment.</b> Emissions of CO <sub>2</sub> from the production of soda ash vary dependent on the manufacturing process. Four different processes may be used to produce soda ash. Three of these processes, monohydrate, sodium sesquicarbonate (trona) and direct carbonation, are referred to as natural processes. The fourth, the Solvay process, is classified as a synthetic process.
2 B 8	<i>Petrochemical and Carbon Black Production</i>	
2 B 8 a	Methanol	Methanol production covers <b>production of methanol from fossil fuel feedstocks [natural gas, petroleum, coal] using steam reforming or partial oxidation processes.</b> Production of methanol from biogenic feedstocks (e.g., by fermentation) is not included in this source category.
2 B 8 b	Ethylene	Ethylene production covers production of ethylene from fossil fuel-derived feedstocks at petrochemical plants by the steam cracking process. Production of ethylene from processes situated within the boundaries of petroleum refineries is not included in this source category. The greenhouse gases produced from ethylene production are carbon dioxide and methane.
2 B 8 c	Ethylene Dichloride and Vinyl Chloride Monomer	Ethylene dichloride and vinyl chloride monomer production covers production of ethylene dichloride by direct oxidation or oxychlorination of ethylene, and the production of vinyl chloride monomer from ethylene dichloride. The greenhouse gases produced from production of ethylene dichloride production and vinyl chloride monomer production are carbon dioxide and methane.
2 B 8 d	Ethylene Oxide	Ethylene oxide production covers production of ethylene oxide by reaction of ethylene and oxygen by catalytic oxidation. The greenhouse gases produced from ethylene oxide production are carbon dioxide and methane.
2 B 8 e	Acrylonitrile	Acrylonitrile production covers production of acrylonitrile from ammoxidation of propylene, and associated production of acetonitrile and hydrogen cyanide from the ammoxidation process. The greenhouse gases produced from production of acrylonitrile are carbon dioxide and methane.
2 B 8 f	Carbon Black	Carbon black production covers production of carbon black from fossil fuel-derived feedstocks (petroleum or coal-derived carbon black feedstock, natural gas, acetylene). Production of carbon black from biogenic feedstocks is not included in this source category.
2 B 8 g	Hydrogen Production	Hydrogen production covers production of hydrogen from steam reforming, gasification, methanol production, ammonia production and processing of crude petroleum. Production of carbon black from

IPCC Source Codes (GHG Activities in terms of Annexure 1 of the Reporting Regulations)	Name	Definition
		biogenic feedstocks is not included in this source category.
2 B 9	<i>Fluorochemical Production</i>	
2 B 9 a	By-product Emissions	Fluorochemical Production covers the complete range of fluorochemicals, whether or not the principal products are greenhouse gases. Emissions encompass HFCs, PFCs, SF <sub>6</sub> and all other halogenated gases with global warming potential listed in IPCC assessment reports. The most significant by-product emission is that of HFC-23 from the manufacture of HCFC-22 and this is described separately.
2 B 9 b	Fugitive Emissions	These are emissions of the principal product from the process to manufacture it and so fluorochemical production in this context is limited to HFCs, PFCs, SF <sub>6</sub> and other halogenated gases with global warming potential listed in IPCC assessment reports.
2 B 10	<i>Other (Please specify)</i>	For example, gases with global warming potential listed in IPCC assessment reports that do not fall within any categories above could be reported here, if they are estimated.
2 C	<b>Metal Industry</b>	
2 C 1	<i>Iron and Steel Production</i>	Carbon dioxide is the predominant gas emitted from the production of iron and steel. The sources of the carbon dioxide emissions include that from carbon-containing reducing agents such as coke and pulverized coal, and, from minerals such as limestone and dolomite added.
2 C 2	<i>Ferroalloys Production</i>	Ferroalloys production covers emissions from primary metallurgical reduction production of the most common ferroalloys, i.e. ferro-silicon, silicon metal, ferro-manganese, silicon manganese, and ferro-chromium, excluding those emissions relating to fuel use. From the production of these alloys, carbon dioxide (CO <sub>2</sub> ), nitrous oxide (N <sub>2</sub> O), and methane (CH <sub>4</sub> ) originating from ore- and reductant raw materials, is emitted.
2 C 3	<i>Aluminium Production</i>	Aluminium Production covers primary production of aluminium, except the emissions related to the use of fuel. Carbon dioxide emissions result from the electrochemical reduction reaction of alumina with a carbon-based anode. Tetrafluoromethane (CF <sub>4</sub> ) and hexafluoroethane (C <sub>2</sub> F <sub>6</sub> ) are also produced intermittently. No greenhouse gases are produced in recycling of aluminium other than from the fuels uses for metal remelting. Sulphur hexafluoride (SF <sub>6</sub> ) emissions are not associated with primary aluminium production; however, casting of some high magnesium containing alloys does result in SF <sub>6</sub> emissions and these emissions are accounted for in Section 2C4, Magnesium Production.
2 C 4	<i>Magnesium Production</i>	Magnesium production covers GHG emissions related to both primary magnesium production as well as oxidation protection of magnesium metal during processing (recycling and casting), excluding those emissions relating to fuel use. In the primary production of magnesium, carbon dioxide (CO <sub>2</sub> ) is emitted during calcination of dolomite and magnesite raw materials. Primary production of magnesium from non-carbonate raw materials does not emit carbon dioxide. In the processing of liquid magnesium, cover gases containing carbon dioxide (CO <sub>2</sub> ), sulphur hexafluoride (SF <sub>6</sub> ), the hydrofluorocarbon HFC 134a or the fluorinated ketone FK 5-1-12 (C <sub>3</sub> F <sub>7</sub> C(O)C <sub>2</sub> F <sub>5</sub> ) may be used. Partial thermal decomposition and/or reaction between these

IPCC Source Codes (GHG Activities in terms of Annexure 1 of the Reporting Regulations)	Name	Definition
		compounds and liquid magnesium generates secondary compounds such as perfluorocarbons (PFCs), which are emitted in addition to unreacted cover gas constituents.
2 C 5	<i>Lead Production</i>	Lead production covers production by the sintering/smelting process as well as direct smelting. Carbon dioxide emissions result as a product of the use of a variety of carbon-based reducing agents in both production processes.
2 C 6	<i>Zinc Production</i>	Zinc production covers emissions from both primary production of zinc from ore as well as recovery of zinc from scrap metals, excluding emissions related to fuel use. Following calcination, zinc metal is produced through one of three methods; 1-electro-thermic distillation, 2-pyro-metallurgical smelting or 3-electrolysis. If method 1 or 2 is used, carbon dioxide (CO <sub>2</sub> ) is emitted. Method 3 does not result in carbon dioxide emissions. Recovery of zinc from metal scrap often uses the same methods as primary production and may thus produce carbon dioxide emissions, which is included in this section.
2 C 7	<i>Other (please specify)</i>	
2 D	<b>Non-Energy Products from Fuels and Solvent Use</b>	The use of oil products and coal-derived oils primarily intended for purposes other than combustion.
2 D 1	<i>Lubricant Use</i>	Lubricating oils, heat transfer oils, cutting oils and greases.
2 D 2	<i>Paraffin Wax Use</i>	Oil-derived waxes such as petroleum jelly, paraffin waxes and other waxes.
2 D 3	<i>Solvent Use</i>	NMVOC emissions from solvent use e.g. in paint application, degreasing and dry cleaning should be contained here. Emissions from the use of HFCs and PFCs as solvents should be reported under 2F5.
2 D 4	<i>Other (please specify)</i>	For example, CH <sub>4</sub> , CO and NMVOC emissions from asphalt production and use (including asphalt blowing), as well as NMVOC emissions from the use of other chemical products than solvents should be contained here, if relevant.
2 E	<b>Electronics Industry</b>	
2 E 1	<i>Integrated Circuit or Semiconductor</i>	Emissions of CF <sub>4</sub> , C <sub>2</sub> F <sub>6</sub> , C <sub>3</sub> F <sub>8</sub> , c-C <sub>4</sub> F <sub>8</sub> , C <sub>4</sub> F <sub>6</sub> , C <sub>4</sub> F <sub>8</sub> O, C <sub>5</sub> F <sub>8</sub> , CHF <sub>3</sub> , CH <sub>2</sub> F <sub>2</sub> , NF <sub>3</sub> and SF <sub>6</sub> from uses of these gases in Integrated Circuit (IC) manufacturing in rapidly evolving ways and in varying amounts, which depend on product (e.g., memory or logic devices) and equipment manufacturer.
2 E 2	<i>TFT Flat Panel Display</i>	Uses and emissions of predominantly CF <sub>4</sub> , CHF <sub>3</sub> , NF <sub>3</sub> and SF <sub>6</sub> during the fabrication of thin-film transistors (TFTs) on glass substrates for flat panel display manufacture. In addition to these gases, C <sub>2</sub> F <sub>6</sub> , C <sub>3</sub> F <sub>8</sub> and c-C <sub>4</sub> F <sub>8</sub> may also be used and emitted during the manufacture of thin and smart displays.
2 E 3	<i>Photovoltaics</i>	Photovoltaic cell manufacture may use and emit CF <sub>4</sub> and C <sub>2</sub> F <sub>6</sub> among others.
2 E 4	<i>Heat Transfer Fluid</i>	Heat transfer fluids, which include several fully fluorinated carbon compounds (either in pure form or in mixtures) with six or more carbon atoms, used and

IPCC Source Codes (GHG Activities in terms of Annexure 1 of the Reporting Regulations)	Name	Definition
		emitted during IC manufacture, testing and assembly. They are used in chillers, temperature shock testers and vapour phase reflow soldering.
2 E 5	<i>Other (please specify)</i>	
2 F	<b>Product Uses as Substitutes for Ozone Depleting Substances</b>	
2 F 1	<i>Refrigeration and Air Conditioning</i>	Refrigeration and air-conditioning systems are usually classified in six application domains or categories. These categories utilise different technologies such as heat exchangers, expansion devices, pipings and compressors. The six application domains are domestic refrigeration, commercial refrigeration, industrial processes, transport refrigeration, stationary air conditioning, mobile air-conditioning systems. For all these applications, various HFCs are selectively replacing CFCs and HCFCs. For example, in developed countries, HFC-134a has replaced CFC-12 in domestic refrigeration and mobile air conditioning systems, and blends of HFCs such as R-407C (HFC-32/HFC-125/HFC-134a) and R-410A (HFC-32/HFC-125) are replacing HCFC-22 mainly in stationary air conditioning. Other, non HFC substances are used to replace CFCs and HCFCs such as iso-butane in domestic refrigeration or ammonia in industrial refrigeration. HFC-152a is also being considered for mobile air conditioning in several regions.
2 F 1 a	Refrigeration and Stationary Air Conditioning	The application domains are domestic refrigeration, commercial refrigeration, industrial processes, stationary air conditioning.
2 F 1 b	Mobile Air Conditioning	The application domains are transport refrigeration, mobile air-conditioning systems.
2 F 2	<i>Foam Blowing Agents</i>	HFCs are being used as replacements for CFCs and HCFCs in foams, particularly in closed-cell insulation applications. Compounds that are being used include HFC-245fa, HFC-365mfc, HFC-227ea, HFC-134a, and HFC-152a. The processes and applications for which these various HFCs are being used include insulation boards and panels, pipe sections, sprayed systems and one-component gap filling foams. For open-cell foams, such as integral skin products for automotive steering wheels and facias, emissions of HFCs used as blowing agents are likely to occur during the manufacturing process. In closed-cell foam, emissions not only occur during the manufacturing phase, but usually extend into the in-use phase and often the majority of emission occurs at the end-of-life (de-commissioning losses). Accordingly, emissions can occur over a period of up to 50 years or even longer.
2 F 3	<i>Fire Protection</i>	There are two general types of fire protection (fire suppression) equipment that use greenhouse gases as partial replacements for halons: portable (streaming) equipment, and fixed (flooding) equipment. The non-ozone depleting, industrial gases HFCs, PFCs and more recently a fluoroketone are mainly used as substitutes for halons, typically halon 1301, in flooding equipment. PFCs played an early role in halon 1301 replacement but current use is limited to replenishment of previously installed systems. HFCs in portable equipment, typically replacing halon 1211, are available but have achieved very limited market acceptance due primarily to their high cost. PFC use in new portable extinguishers is currently limited to a small amount (few percent) in an HCFC blend.

IPCC Source Codes (GHG Activities in terms of Annexure 1 of the Reporting Regulations)	Name	Definition
2 F 4	<i>Aerosols</i>	Most aerosol packages now contain hydrocarbon (HC) as propellants but, in a small fraction of the total, HFCs and PFCs may be used as propellants or solvents. Emissions from aerosols usually occur shortly after production, on average six months after sale. During the use of aerosols, 100% of the chemical is emitted. The 5 main sources are metered dose inhalers (MDIs), personal care products (e.g. hair care, deodorant, shaving cream), household products (e.g. air-fresheners, oven and fabric cleaners), industrial products (e.g. special cleaning sprays such as those for operating electrical contact, lubricants, pipe-freezers) and other general products (e.g. silly string, tire inflators, claxons), although in some regions the use of such general products is restricted. The HFCs currently used as propellants are HFC 134a, HFC 227ea, and HFC 152a. The substance HFC 43 10mee and a PFC, perfluorohexane, are used as solvents in industrial aerosol products.
2 F 5	<i>Solvents</i>	HFCs and, to a much lesser extent PFCs, are being used as substitutes for ozone depleting substances (most notably CFC-113). Typical HFCs used are HFC-365mfc and HFC-43-10mee. Use of these fluorinated replacements is much less widespread than the ozone depleting substances they replace. Re-capture and re-use is also much more widely practiced. The primary areas of use are precision cleaning, electronics cleaning, metal cleaning and deposition applications. Emissions from aerosols containing solvents should be reported under category 2F4 "Aerosols" rather than under this category.
2 F 6	<i>Other Applications (please specify)</i>	The properties of ozone depleting substances have made them attractive for a variety of niche applications not covered in other sub-source categories. These include electronics testing, heat transfer, dielectric fluid and medical applications. The properties of HFCs and PFCs are equally attractive in some of these sectors and they have been adopted as substitutes. There are also some historical uses of PFCs, as well as emerging use of HFCs, in these applications. These applications have leakage rates ranging from 100% emissive in year of application to around 1% per annum.
2 G	<b>OTHER PRODUCT MANUFACTURE AND USE</b>	
2 G 1	<i>Electrical Equipment</i>	Electrical equipment is used in the transmission and distribution of electricity above 1 kV. SF <sub>6</sub> is used in gas-insulated switchgear (GIS), gas circuit breakers (GCB), gas-insulated transformers (GIT), gas-insulated lines (GIL), outdoor gas-insulated instrument transformers, reclosers, switches, ring main units and other equipment.
2 G 1 a	Manufacture of Electrical Equipment	
2 G 1 b	Use of Electrical Equipment	
2 G 1 c	Disposal of Electrical Equipment	
2 G 2	<i>SF<sub>6</sub> and PFCs from Other Product Uses</i>	
2 G 2 a	Military Applications	Military applications include AWACS, which are military reconnaissance planes of the Boeing E-3A type. In AWACS (and possibly other reconnaissance planes), the SF <sub>6</sub> is used as an insulating gas in the radar system.
2 G 2 b	Accelerators	Particle accelerators are used for research purposes (at universities and research institutions), for industrial applications (in cross-linking polymers for cable insulation and for rubber parts and hoses), and in medical (radiotherapy) applications.

IPCC Source Codes (GHG Activities in terms of Annexure 1 of the Reporting Regulations)	Name	Definition
2 G 2 c	Other ( <i>please specify</i> )	This source includes adiabatic uses, sound-proof glazing, PFCs used as heat transfer fluids in consumer and commercial applications, PFCs used in cosmetic and medical applications, and PFCs and SF <sub>6</sub> used as tracers.
2 G 3	<i>N<sub>2</sub>O from Product Uses</i>	
2 G 3 a	Medical Applications	This source covers evaporative emissions of nitrous oxide (N <sub>2</sub> O) that arise from medical applications (anaesthetic use, analgesic use and veterinary use). N <sub>2</sub> O is used during anaesthesia for two reasons: a) as an anaesthetic and analgesic and as b) a carrier gas for volatile fluorinated hydrocarbon anaesthetics such as isoflurane, sevoflurane and desflurane.
2 G 3 b	Propellant for Pressure and Aerosol Products	This source covers evaporative emissions of nitrous oxide (N <sub>2</sub> O) that arise from use as a propellant in aerosol products primarily in food industry. Typical usage is to make whipped cream, where cartridges filled with N <sub>2</sub> O are used to blow the cream into foam.
2 G 3 c	Other (Please specify)	
2 G 4	<i>Other (Please specify)</i>	
2 H	<b>Other</b>	
2 H 1	<i>Pulp and Paper Industry</i>	
2 H 2	<i>Food and Beverages Industry</i>	
2 H 3	<i>Other (please specify)</i>	
<b>3</b>	<b>AGRICULTURE, FORESTRY, AND OTHER LAND USE</b>	Emissions and removals from forest land, cropland, grassland, wetlands, settlements, and other land. Also includes emissions from livestock and manure management, emissions from managed soils, and emissions from liming and urea application. Methods to estimate annual harvested wood product (HWP) variables are also covered in this category.
3 A	<b>Livestock</b>	Methane emissions from enteric fermentation, and methane and nitrous oxide emissions from manure management.
3 A 1	<i>Enteric Fermentation</i>	Methane emissions from herbivores as a by-product of enteric fermentation (a digestive process by which carbohydrates are broken down by micro-organisms into simple molecules for absorption into the bloodstream). Ruminant animals (e.g., cattle, sheep) are major sources with moderate amounts produced from non-ruminant animals (e.g., pigs, horses).
3 A 1 a	Cattle	Methane emissions from dairy cows and other cattle.
3 A 1 a i	<i>Dairy Cows</i>	Methane emissions from cattle producing milk for commercial exchange and from calves and heifers being grown for dairy purposes.
3 A 1 a ii	<i>Other Cattle</i>	Methane emissions from all non-dairy cattle including: cattle kept or grown for meat production, draft animals, and breeding animals.
3 A 1 b	Buffalo	Methane emissions from buffalo.
3 A 1 c	Sheep	Methane emissions from sheep.
3 A 1 d	Goats	Methane emissions from goats.
3 A 1 e	Camels	Methane emissions from camels.
3 A 1 f	Horses	Methane emissions from horses.
3 A 1 g	Mules and Asses	Methane emissions from mules and asses.
3 A 1 h	Swine	Methane emissions from swine.
3 A 1 j	Other (please specify)	Methane emissions from other livestock (e.g. alpacas, llamas, deer, reindeer, etc.).

IPCC Source Codes (GHG Activities in terms of Annexure 1 of the Reporting Regulations)	Name	Definition
3 A 2	<i>Manure Management</i>	Methane and nitrous oxide emissions from the decomposition of manure under low oxygen or anaerobic conditions. These conditions often occur when large numbers of animals are managed in a confined area (e.g. dairy farms, beef feedlots, and swine and poultry farms), where manure is typically stored in large piles or disposed of in lagoons and other types of manure management systems.
3 A 2 a	Cattle	Methane and nitrous oxide emissions from the decomposition of manure from cattle.
3 A 2 a i	<i>Dairy Cows</i>	Methane and nitrous oxide emissions from the decomposition of manure from dairy cows.
3 A 2 a ii	<i>Other Cattle</i>	Methane and nitrous oxide emissions from the decomposition of manure from other cattle.
3 A 2 b	Buffalo	Methane and nitrous oxide emissions from the decomposition of manure from buffalo.
3 A 2 c	Sheep	Methane and nitrous oxide emissions from the decomposition of manure from sheep.
3 A 2 d	Goats	Methane and nitrous oxide emissions from the decomposition of manure from goats.
3 A 2 e	Camels	Methane and nitrous oxide emissions from the decomposition of manure from camels.
3 A 2 f	Horses	Methane and nitrous oxide emissions from the decomposition of manure from horses.
3 A 2 g	Mules and Asses	Methane and nitrous oxide emissions from the decomposition of manure from mules and asses.
3 A 2 h	Swine	Methane and nitrous oxide emissions from the decomposition of manure from swine.
3 A 2 i	Poultry	Methane and nitrous oxide emissions from the decomposition of manure from poultry including chicken, broilers, turkeys, and ducks.
3 A 2 j	Other (please specify)	Methane and nitrous oxide emissions from the decomposition of manure from other livestock (e.g. alpacas, llamas, deer, reindeer, fur-bearing animals, ostriches, etc.)
3 B	<b>Land</b>	Emissions and removals from five land use categories (Forest land, Cropland, Grasslands, Settlements, and Other land) except for sources listed under 3C (Aggregate sources and non-CO2 emissions sources on land) . Except for Wetlands, the greenhouse gas inventory involves estimation of changes in carbon stock from five carbon pools (i.e. aboveground biomass, belowground biomass, dead wood, litter, and soil organic matter), as appropriate.
3 B 1	<i>Forest Land</i>	Emissions and removals from lands with woody vegetation consistent with thresholds used to define forest land in the national GHG inventory, sub-divided into managed and unmanaged, and possibly also by climatic region, soil type and vegetation type as appropriate. It also includes systems with vegetation that currently fall below, but are expected to later exceed, the threshold values used by a country to define the forest land category.
3 B 1 a	Forest land Remaining Forest Land	Emissions and removals from managed forests and plantations which have always been under forest land use or other land categories converted to forest over 20 years ago (default assumption).
3 B 1 b	Land Converted to Forest Land	Emissions and removals from lands converted to forest land. Includes conversion of cropland, grassland, wetlands, settlements, and other land to forest land. Even abandoned lands which are regenerating to forest due to human activities are also included.
3 B 1 b i	<i>Cropland Converted to Forest Land</i>	Emissions and removals from cropland converted to forest land.

IPCC Source Codes (GHG Activities in terms of Annexure 1 of the Reporting Regulations)	Name	Definition
3 B 1 b ii	<i>Grassland Converted to Forest Land</i>	Emissions and removals from grassland converted to forest land.
3 B 1 b iii	<i>Wetlands Converted to Forest Land</i>	Emissions and removals from wetlands converted to forest land.
3 B 1 b iv	<i>Settlements Converted to Forest Land</i>	Emissions and removals from settlements converted to forest land.
3 B 1 b v	<i>Other Land Converted to Forest Land</i>	Emissions and removals from other land converted to forest land.
3 B 2	<i>Cropland</i>	Emissions and removals from arable and tillage land, rice fields, and agro-forestry systems where vegetation falls below the thresholds used for the forest land category.
3 B 2 a	Cropland Remaining Cropland	Emissions and removals from cropland that has not undergone any land use change during the inventory period.
3 B 2 b	Land Converted to Cropland	Emissions and removals from lands converted to cropland. Includes conversion of forest land, grassland, wetlands, settlements, and other land to cropland.
3 B 2 b i	<i>Forest Land Converted to Cropland</i>	Emissions and removals from forest land converted to cropland.
3 B 2 b ii	<i>Grassland Converted to Cropland</i>	Emissions and removals from grassland converted to cropland.
3 B 2 b iii	<i>Wetlands Converted to Cropland</i>	Emissions and removals from wetlands converted to cropland.
3 B 2 b iv	<i>Settlements Converted to Cropland</i>	Emissions and removals from settlements converted to cropland.
3 B 2 b v	<i>Other Land Converted to Cropland</i>	Emissions and removals from other land converted to cropland.
3 B 3	<i>Grassland</i>	Emissions and removals from rangelands and pasture land that is not considered cropland. It also includes systems with woody vegetation that fall below the threshold values used in the forest land category and are not expected to exceed them, without human intervention. The category also includes all grassland from wild lands to recreational areas as well as agricultural and silvi-pastoral systems, subdivided into managed and unmanaged, consistent with national definitions.
3 B 3 a	Grassland Remaining Grassland	Emissions and removals from grassland remaining grassland.
3 B 3 b	Land Converted to Grassland	Emissions and removals from land converted to grassland.
3 B 3 b i	<i>Forest Land Converted to Grassland</i>	Emissions and removals from forest land converted to grassland.
3 B 3 b ii	<i>Cropland Converted to Grassland</i>	Emissions and removals from cropland converted to grassland.
3 B 3 b iii	<i>Wetlands Converted to Grassland</i>	Emissions and removals from wetlands converted to grassland.
3 B 3 b iv	<i>Settlements Converted to Grassland</i>	Emissions and removals from settlements converted to grassland.
3 B 3 b v	<i>Other Land Converted to Grassland</i>	Emissions and removals from other land converted to grassland.
3 B 4	<i>Wetlands</i>	Emissions from land that is covered or saturated by water for all or part of the year (e.g., peatland) and that does not fall into the forest land, cropland, grassland or settlements categories. The category can be subdivided into managed and unmanaged according to national definitions. It includes reservoirs as a managed subdivision and natural rivers and lakes as unmanaged subdivisions.
3 B 4 a	Wetlands Remaining Wetlands	Emissions from peatland undergoing peat extraction and from flooded land remaining flooded land.



IPCC Source Codes (GHG Activities in terms of Annexure 1 of the Reporting Regulations)	Name	Definition
3 B 4 a i	<i>Peatlands Remaining peatlands</i>	Includes (1) on-site emissions from peat deposits during the extraction phase and (2) off-site emissions from horticultural use of peat. The off-site emissions from the energy use of peat are reported in the Energy Sector and are therefore not included in this category.
3 B 4 a ii	<i>Flooded Land Remaining Flooded Land</i>	Emissions from flooded land remaining flooded land. Flooded lands are defined as water bodies where human activities have caused changes in the amount of surface area covered by water, typically through water level regulation. Examples of flooded lands include reservoirs for the production of hydroelectricity, irrigation, navigation, etc. Regulated lakes and rivers that have not experienced substantial changes in water area in comparison with the pre-flooded ecosystem are not considered as flooded lands. Some rice paddies are cultivated through flooding of land, but because of the unique characteristics of rice cultivation, rice paddies are addressed in 3C7.
3 B 4 b	Land Converted to Wetlands	Emissions from land being converted for peat extraction from land converted to wetland.
3 B 4 b i	<i>Land Converted for Peat Extraction</i>	Emissions from land being converted for peat extraction
3 B 4 b ii	<i>Land Converted to Flooded Land</i>	Emissions from land converted to flooded land
3 B 4 b iii	<i>Land Converted to Other Wetlands</i>	Emissions from land converted to other wetlands than flooded land and land for peat extraction.
3 B 5	<i>Settlements</i>	Emissions and removals from all developed land, including transportation infrastructure and human settlements of any size, unless they are already included under other categories. This should be consistent with national definitions.
3 B 5 a	Settlements Remaining Settlements	Emissions and removals from settlements that have not undergone any land use change during the inventory period.
3 B 5 b	Land Converted to Settlements	Emissions and removals from lands converted to settlements. Includes conversion of forest land, cropland, grassland, wetlands, and other land to settlements.
3 B 5 b i	<i>Forest Land Converted to Settlements</i>	Emissions and removals from forest land converted to settlements.
3 B 5 b ii	<i>Cropland Converted to Settlements</i>	Emissions and removals from cropland converted to settlements.
3 B 5 b iii	<i>Grassland Converted to Settlements</i>	Emissions and removals from grassland converted to settlements.
3 B 5 b iv	<i>Wetlands Converted to Settlements</i>	Emissions and removals from wetlands converted to settlements.
3 B 5 b v	<i>Other Land Converted to Settlements</i>	Emissions and removals from other land converted to settlements.
3 B 6	<i>Other Land</i>	Emissions and removals from bare soil, rock, ice, and all unmanaged land areas that do not fall into any of the other five categories. It allows the total of identified land areas to match the national area, where data are available.
3 B 6 a	Other Land Remaining Other Land	Emissions and removals from other land that has not undergone any land use change during the inventory period.
3 B 6 b	Land Converted to Other Land	Emissions and removals from lands converted to other land. Includes conversion of forest land, cropland, grassland, wetlands, and settlements to other land.
3 B 6 b i	<i>Forest Land Converted to Other Land</i>	Emissions and removals from forest land converted to other land.
3 B 6 b ii	<i>Cropland Converted to Other Land</i>	Emissions and removals from cropland converted to other land.
3 B 6 b iii	<i>Grassland Converted to Other Land</i>	Emissions and removals from grassland converted to other land.
3 B 6 b iv	<i>Wetlands Converted to Other Land</i>	Emissions and removals from wetlands converted to other land.

IPCC Source Codes (GHG Activities in terms of Annexure 1 of the Reporting Regulations)	Name	Definition
3 B 6 b v	<i>Settlements Converted to Other Land</i>	Emissions and removals from settlements converted to other land.
3 C	<b>Aggregate Sources and Non-CO<sub>2</sub> Emissions Sources on Land</b>	Includes emissions from activities that are likely to be reported at very high aggregation land level or even country level.
3 C 1	<i>Emissions from Biomass Burning</i>	Emissions from biomass burning that include N <sub>2</sub> O and CH <sub>4</sub> . CO <sub>2</sub> emissions are included here only if emissions are not included in 3B categories as carbon stock changes.
3 C 1 a	Biomass Burning in Forest Lands	Emissions from biomass burning that include N <sub>2</sub> O and CH <sub>4</sub> in forest lands. CO <sub>2</sub> emissions are included here only if emissions are not included in 3B1 categories as carbon stock changes.
3 C 1 b	Biomass Burning in Croplands	Emissions from biomass burning that include N <sub>2</sub> O and CH <sub>4</sub> in croplands. CO <sub>2</sub> emissions are included here only if emissions are not included in 3B2 categories as carbon stock changes.
3 C 1 c	Biomass Burning in Grasslands	Emissions from biomass burning that include N <sub>2</sub> O and CH <sub>4</sub> in grasslands. CO <sub>2</sub> emissions are included here only if emissions are not included in 3B3 categories as carbon stock changes.
3 C 1 d	Biomass Burning in All Other Land	Emissions from biomass burning that include N <sub>2</sub> O and CH <sub>4</sub> in settlements, and all other land. CO <sub>2</sub> emissions are included here only if emissions are not included in 3B6 categories as carbon stock changes.
3 C 2	<i>Liming</i>	CO <sub>2</sub> emissions from the use of lime in agricultural soils, managed forest soils or lakes.
3 C 3	<i>Urea Application</i>	CO <sub>2</sub> emissions from urea application
3 C 4	<i>Direct N<sub>2</sub>O Emissions from Managed Soils</i>	Direct N <sub>2</sub> O emissions from managed soils from the synthetic N fertilizers application; organic N applied as fertilizer (e.g. animal manure, compost, sewage sludge, rendering waste); urine and dung N deposited on pasture, range and paddock by grazing animals; N in crop residues (above and below ground), including from N-fixing crops and from forages during pasture renewal; N mineralization/immobilization associated with loss/gain of soil organic matter resulting from change of land use or management of mineral soils; and drainage/management of organic soils (i.e., histosols).
3 C 5	<i>Indirect N<sub>2</sub>O Emissions from Managed Soils</i>	Indirect N <sub>2</sub> O emissions from: (1) the volatilization of N (as NH <sub>3</sub> and NO <sub>x</sub> ) following the application of synthetic and organic N fertilizers and /or urine and dung deposition from grazing animals, and the subsequent deposition of the N as ammonium (NH <sub>4</sub> <sup>+</sup> ) and oxides of N (NO <sub>x</sub> ) on soils and waters, and (2) the leaching and runoff of N from synthetic and organic N fertilizer additions, crop residues, mineralization /immobilization of N associated with loss/gain of soil C in mineral soils through land use change or management practices, and urine and dung deposition from grazing animals, into groundwater, riparian areas and wetlands, rivers and eventually the coastal ocean.
3 C 6	<i>Indirect N<sub>2</sub>O Emissions from Manure Management</i>	Indirect N <sub>2</sub> O emissions from manure management (activity data amount of nitrogen in the manure excreted).
3 C 7	<i>Rice Cultivations</i>	Methane (CH <sub>4</sub> ) emissions from anaerobic decomposition of organic material in flooded rice fields. Any N <sub>2</sub> O emissions from the use of nitrogen-based fertilizers in rice cultivation should be reported under N <sub>2</sub> O emissions from managed soils.
3 C 8	<i>Other (please specify)</i>	Other sources of CH <sub>4</sub> and N <sub>2</sub> O emissions on land.
3 D	<b>Other</b>	

IPCC Source Codes (GHG Activities in terms of Annexure 1 of the Reporting Regulations)	Name	Definition
3 D 1	<i>Harvested Wood Products</i>	CO <sub>2</sub> net emissions or removals resulting from Harvest Wood Products.
3 D 2	<i>Other (please specify)</i>	
4	<b>WASTE</b>	
4 A	<b>Solid Waste Disposal</b>	Methane is produced from anaerobic microbial decomposition of organic matter in solid waste disposal sites. Carbon dioxide (CO <sub>2</sub> ) is also produced but CO <sub>2</sub> from biogenic or organic waste sources is covered by the AFOLU Sector. Emissions of halogenated gases should be accounted in IPPU. Long-term storage of carbon in SWDS is reported as an information item.
4 A 1	<i>Managed Waste Disposal Sites</i>	A managed solid waste disposal site must have controlled placement of waste (i.e. waste directed to specific deposition areas, a degree of control of scavenging and fires) and will include at least one of the following: cover material; mechanical compaction; or levelling of the waste. This category can be subdivided into aerobic and anaerobic.
4 A 2	<i>Unmanaged Waste Disposal Sites</i>	These are all other solid waste disposal sites that do not fall into the above category. This category can be subdivided into deep and shallow.
4 A 3	<i>Uncategorised Waste Disposal Sites</i>	Mixture of above 4 A1 and 4 A2. Countries that do not have data on division of managed/unmanaged may use this category.
4 B	<b>Biological Treatment of Solid Waste</b>	Solid waste composting and other biological treatment. Emissions from biogas facilities (anaerobic digestion) with energy production are reported in the Energy Sector (1A4).
4 C	<b>Incineration and Open Burning of Waste</b>	Incineration of waste and open burning waste, not including waste-to-energy facilities. Emissions from waste burnt for energy are reported under the Energy Sector, 1A. Emissions from burning of agricultural wastes should be reported under AFOLU (3C1). All non-CO <sub>2</sub> greenhouse gases as well as CO <sub>2</sub> from fossil waste should be reported here for incineration and open burning.
4 C 0	<i>Waste Pyrolysis</i>	Thermochemical conversion of organic materials into gas and liquid products, at elevated temperatures and in the absence of oxygen.
4 C 1	<i>Waste Incineration</i>	Combustion of solid wastes in controlled incineration facilities.
4 C 2	<i>Open Burning of Waste</i>	Combustion of waste in the open-air or in an open dump.
4 D	<b>Wastewater Treatment and Discharge</b>	Methane is produced from anaerobic decomposition of organic matter by bacteria in sewage facilities and from food processing and other industrial facilities during wastewater treatment. N <sub>2</sub> O is also produced by bacteria (denitrification and nitrification) in wastewater treatment and discharge.
4 D 1	<i>Domestic Wastewater Treatment and Discharge</i>	Treatment and discharge of liquid wastes and sludge from housing and commercial sources (including human waste) through: wastewater sewage systems collection and treatment systems, open pits / latrines, anaerobic lagoons, anaerobic reactors and discharge into surface waters. Emissions from sludge disposed at SWDS are reported under category 4A.
4 D 2	<i>Industrial Wastewater Treatment and Discharge</i>	Treatment and discharge of liquid wastes and sludge from industrial processes such as: food processing, textiles, or pulp and paper production. This includes anaerobic lagoons, anaerobic reactors, and discharge into surface waters. Industrial wastewater released into domestic wastewater sewage should be included under 4D1.

IPCC Source Codes (GHG Activities in terms of Annexure 1 of the Reporting Regulations)	Name	Definition
4 E	<b>Other (please specify)</b>	Release of GHGs from other waste handling activities than listed in categories 4A to 4D.
<b>5</b>	<b>Other</b>	
5 A	Indirect N <sub>2</sub> O Emissions from the Atmospheric Deposition of Nitrogen in NO <sub>x</sub> and NH <sub>3</sub>	Excluding indirect emissions from NO <sub>x</sub> and NH <sub>3</sub> in agriculture which are reported in 3C2.
5 B	Other (please specify)	Only use this category exceptionally, for any categories than cannot be accommodated in the categories described above. Include a reference to where a detailed explanation of the category can be found.

### Annexure G: Global Warming Potential Values. IPCC Third Assessment Report, 2001 (IPCC 2001, Ch6, 388)

Gas		Radiative efficiency (Wm <sup>-2</sup> ppb <sup>-1</sup> ) (from (b) unless indicated)	Lifetime (years) (from Chapter 4 unless indicated)	Global Warming Potential		
				20 years	100 years	500 years
<b>Carbon dioxide</b>	CO <sub>2</sub>	See Section 6.12.2 of IPCC TAR report	See Section 6.12.2 of the IPCC TAR report	1	1	1
<b>Methane</b>	CH <sub>4</sub>	3.7x10 <sup>-4</sup> <sub>a</sub>	12.0*	62	23	7
<b>Nitrous oxide</b>	N <sub>2</sub> O	3.1x10 <sup>-3</sup> <sub>a</sub>	114*	275	296	156
Chlorofluorocarbons						
<b>CFC-11</b>	CCl <sub>3</sub> F	0.25	45	6300	4600	1600
<b>CFC-12</b>	CCl <sub>2</sub> F <sub>2</sub>	0.32	100	10200	10600	5200
<b>CFC-13</b>	CClF <sub>3</sub>	0.25	640 (c)	10000	14000	16300
<b>CFC-113</b>	CCl <sub>2</sub> FCClF <sub>2</sub>	0.30	85	6100	6000	2700
<b>CFC-114</b>	CClF <sub>2</sub> CClF <sub>2</sub>	0.31	300	7500	9800	8700
<b>CFC-115</b>	CF <sub>3</sub> CClF <sub>2</sub>	0.18 <sub>a</sub>	1700	4900	7200	9900
Hydrochlorofluorocarbons						
<b>HCFC-21</b>	CHClF	0.17	2.0 (d)	700	210	65
<b>HCFC-22</b>	CHClF <sub>2</sub>	0.20 <sub>b</sub>	11.9	4800	1700	540
<b>HCFC-123</b>	CF <sub>3</sub> CHCl <sub>2</sub>	0.20	1.4 (a)	390	120	36
<b>HCFC-124</b>	CF <sub>3</sub> CHClF	0.22	6.1 (a)	2000	620	190
<b>HCFC-141b</b>	CH <sub>3</sub> CCl <sub>2</sub> F	0.14	9.3	2100	700	220
<b>HCFC-142b</b>	CH <sub>3</sub> CClF <sub>2</sub>	0.20	19	5200	2400	740
<b>HCFC-225ca</b>	CF <sub>3</sub> CF <sub>2</sub> CHCl <sub>2</sub>	0.27	2.1 (a)	590	180	55
<b>HCFC-225cb</b>	CClF <sub>2</sub> CF <sub>2</sub> CHClF	0.32	6.2 (a)	2000	620	190
Hydrofluorocarbons						
<b>HFC-23</b>	CHF <sub>3</sub>	0.16 <sub>c</sub>	260	9400	12000	10000
<b>HFC-32</b>	CH <sub>2</sub> F <sub>2</sub>	0.09 <sub>c</sub>	5.0	1800	550	170
<b>HFC-41</b>	CH <sub>3</sub> F	0.02	2.6	330	97	30
<b>HFC-125</b>	CHF <sub>2</sub> CF <sub>3</sub>	0.23 <sub>c</sub>	29	5900	3400	1100
<b>HFC-134</b>	CHF <sub>2</sub> CHF <sub>2</sub>	0.18	9.6	3200	1100	330
<b>HFC-134a</b>	CH <sub>2</sub> FCF <sub>3</sub>	0.15 <sub>c</sub>	13.8	3300	1300	400
<b>HFC-143</b>	CHF <sub>2</sub> CH <sub>2</sub> F	0.13	3.4	1100	330	100
<b>HFC-143a</b>	CF <sub>3</sub> CH <sub>3</sub>	0.13 <sub>c</sub>	52	5500	4300	1600
<b>HFC-152</b>	CH <sub>2</sub> FCH <sub>2</sub> F	0.09	0.5	140	43	13
<b>HFC-152a</b>	CH <sub>3</sub> CHF <sub>2</sub>	0.09 <sub>c</sub>	1.4	410	120	37
<b>HFC-161</b>	CH <sub>3</sub> CH <sub>2</sub> F	0.03	0.3	40	12	4
<b>HFC-227ea</b>	CF <sub>3</sub> CHFCF <sub>3</sub>	0.30	33.0	5600	3500	1100
<b>HFC-236cb</b>	CH <sub>2</sub> FCF <sub>2</sub> CF <sub>3</sub>	0.23	13.2	3300	1300	390
<b>HFC-236ea</b>	CHF <sub>2</sub> CHF <sub>2</sub> CF <sub>3</sub>	0.30	10.0	3600	1200	390
<b>HFC-236fa</b>	CF <sub>3</sub> CH <sub>2</sub> CF <sub>3</sub>	0.28	220	7500	9400	7100
<b>HFC-245ca</b>	CH <sub>2</sub> FCF <sub>2</sub> CHF <sub>2</sub>	0.23	5.9	2100	640	200
<b>HFC-245fa</b>	CHF <sub>2</sub> CH <sub>2</sub> CF <sub>3</sub>	0.28 <sub>a</sub>	7.2	3000	950	300

Gas	Chemical structure	Radiative efficiency (Wm <sup>-2</sup> ppb <sup>-1</sup> ) (from (b) unless indicated)	Lifetime (years) (from Chapter 4 unless indicated)	Global Warming Potential		
				20 years	100 years	500 years
<b>HFC-365mfc</b>	CF <sub>3</sub> CH <sub>2</sub> CF <sub>2</sub> C H <sub>3</sub>	0.21 (k)	9.9	2600	<b>890</b>	300
<b>HFC-43-10mee</b>	CF <sub>3</sub> CHFCHF CF <sub>2</sub> CF <sub>3</sub>	0.40	15	3700	<b>1500</b>	470
Chlorocarbons						
<b>CH<sub>3</sub>CCl<sub>3</sub></b>		0.06	4.8	450	<b>140</b>	42
<b>CCl<sub>4</sub></b>		0.13 <sup>†</sup>	35	2700	<b>1800</b>	580
<b>CHCl<sub>3</sub></b>		0.11 <sub>s</sub>	0.51 (a)	100	<b>30</b>	9
<b>CH<sub>3</sub>Cl</b>		0.01	1.3 (b)	55	<b>16</b>	5
<b>CH<sub>2</sub>Cl<sub>2</sub></b>		0.03	0.46 (a)	35	<b>10</b>	3
Bromocarbons						
<b>CH<sub>3</sub>Br</b>		0.01	0.7 (b)	16	<b>5</b>	1
<b>CH<sub>2</sub>Br<sub>2</sub></b>		0.01	0.41 (i)	5	<b>1</b>	<<1
<b>CHBrF<sub>2</sub></b>		0.14	7.0 (i)	1500	<b>470</b>	150
<b>Halon-1211</b>	CBrClF <sub>2</sub>	0.30	11	3600	<b>1300</b>	390
<b>Halon-1301</b>	CBrF <sub>3</sub>	0.32	65	7900	<b>6900</b>	2700
Iodocarbons						
<b>CF<sub>3</sub>I</b>		0.23	0.005 (a)	1	<b>1</b>	<<1
Fully fluorinated species						
<b>SF<sub>6</sub></b>		0.52	3200	15100	<b>22200</b>	32400
<b>CF<sub>4</sub></b>		0.08	50000	3900	<b>5700</b>	8900
<b>C<sub>2</sub>F<sub>6</sub></b>		0.26 <sub>s</sub>	10000	8000	<b>11900</b>	18000
<b>C<sub>3</sub>F<sub>8</sub></b>		0.26	2600	5900	<b>8600</b>	12400
<b>C<sub>4</sub>F<sub>10</sub></b>		0.33	2600	5900	<b>8600</b>	12400
<b>c-C<sub>4</sub>F<sub>8</sub></b>		0.32 <sub>s</sub>	3200	6800	<b>10000</b>	14500
<b>C<sub>3</sub>F<sub>12</sub></b>		0.41	4100	6000	<b>8900</b>	13200
<b>C<sub>6</sub>F<sub>14</sub></b>		0.49	3200	6100	<b>9000</b>	13200
Ethers and Halogenated Ethers						
<b>CH<sub>3</sub>OCH<sub>3</sub></b>		0.02	0.015 (e)	1	<b>1</b>	<<1
<b>(CF<sub>3</sub>)<sub>2</sub>CFOCH<sub>3</sub></b>		0.31	3.4 (l)	1100	<b>330</b>	100
<b>(CF<sub>3</sub>)CH<sub>2</sub>OH</b>		0.18	0.5 (m)	190	<b>57</b>	18
<b>CF<sub>3</sub>CF<sub>2</sub>CH<sub>2</sub>OH</b>		0.24	0.4 (m)	140	<b>40</b>	13
<b>(CF<sub>3</sub>)<sub>2</sub>CHOH</b>		0.28	1.8 (m)	640	<b>190</b>	59
<b>HFE-125</b>	CF <sub>3</sub> OCHF <sub>2</sub>	0.44	150	12900	<b>14900</b>	9200
<b>HFE-134</b>	CHF <sub>2</sub> OCHF <sub>2</sub>	0.45	26.2	10500	<b>6100</b>	2000
<b>HFE-143a</b>	CH <sub>3</sub> OCF <sub>3</sub>	0.27	4.4	2500	<b>750</b>	230
<b>HCFE-235da2</b>	CF <sub>3</sub> CHClOC HF <sub>2</sub>	0.38	2.6 (i)	1100	<b>340</b>	110
<b>HFE-245cb2</b>	CF <sub>3</sub> CF <sub>2</sub> OCH <sub>3</sub>	0.32	4.3 (l)	1900	<b>580</b>	180
<b>HFE-245fa2</b>	CF <sub>3</sub> CH <sub>2</sub> OCH F <sub>2</sub>	0.31	4.4 (i)	1900	<b>570</b>	180

Gas	Radiative efficiency (Wm <sup>-2</sup> ppb <sup>-1</sup> ) (from (b) unless indicated)	Lifetime (years) (from Chapter 4 unless indicated)	Global Warming Potential			
			Time horizon 20 years	100 years	500 years	
<b>HFE-254cb2</b>	CHF <sub>2</sub> CF <sub>2</sub> OC H <sub>3</sub>	0.28	0.22 (h)	99	<b>30</b>	9
<b>HFE-347mcc3</b>	CF <sub>3</sub> CF <sub>2</sub> CF <sub>2</sub> O CH <sub>3</sub>	0.34	4.5 (l)	1600	<b>480</b>	150
<b>HFE-356pcf3</b>	CHF <sub>2</sub> CF <sub>2</sub> CH <sub>2</sub> OCHF <sub>2</sub>	0.39	3.2 (n)	1500	<b>430</b>	130
<b>HFE-374pc2</b>	CHF <sub>2</sub> CF <sub>2</sub> OCH <sub>2</sub> CH <sub>3</sub>	0.25	5.0 (n)	1800	<b>540</b>	170
<b>HFE-7100</b>	C <sub>4</sub> F <sub>9</sub> OCH <sub>3</sub>	0.31	5.0 (f)	1300	<b>390</b>	120
<b>HFE-7200</b>	C <sub>4</sub> F <sub>9</sub> OC <sub>2</sub> H <sub>5</sub>	0.30 <sup>Ω</sup>	0.77 (g)	190	<b>55</b>	17
<b>H-Galden 1040x</b>	CHF <sub>2</sub> OCF <sub>2</sub> O C <sub>2</sub> F <sub>4</sub> O CHF <sub>2</sub>	1.37(j) <sup>Ω</sup>	6.3 <sup>Ω</sup>	5900	<b>1800</b>	560
<b>HG-10</b>	CHF <sub>2</sub> OCF <sub>2</sub> O CHF <sub>2</sub>	0.66 <sup>Ω</sup>	12.1 <sup>Ω</sup>	7500	<b>2700</b>	850
<b>HG-01</b>	CHF OCF CF OC HF <sub>2</sub>	0.87 <sup>Ω</sup>	6.2 <sup>Ω</sup>	4700	<b>1500</b>	450

\* The values for CH<sub>4</sub> and N<sub>2</sub>O are adjustment times including feedbacks of emission on lifetimes (see Chapter 4 of the IPCC TAR WGI report).  
 □ From the formulas given in Table 6.2 of the IPCC WGI TAR report, with updated constants based on the IPCC (1990) expressions.

Note: For all gases destroyed by reaction with OH, updated lifetimes include scaling to CH<sub>3</sub>CCl<sub>3</sub> lifetimes, as well as an estimate of the stratospheric destruction. See references below for rates along with Chapter 4 and WMO (1999).

(a) Taken from the SAR (b) Taken from WMO (1999) (c) Taken from WMO (1995) (d) DeMore *et al.* (1997)  
 (e) Good *et al.* (1998) (f) Wallington *et al.* (1997) (g) Christensen *et al.* (1998) (h) Heathfield *et al.* (1998a)  
 (i) Christidis *et al.* (1997) (j) Gierczak *et al.* (1996) (k) Barry *et al.* (1997) (l) Tokuhashi *et al.* (1999a)  
 (m) Tokuhashi *et al.* (1999b) (n) Tokuhashi *et al.* (2000)

† Myhre *et al.* (1998b) †† Jain *et al.* (2000) § Highwood and Shine (2000) & Ko *et al.* (1999).

<sup>Ω</sup> See Cavalli *et al.* (1998) and Myhre *et al.* (1999)

### 57. Annexure H: Default factors to estimate poultry manure management emissions

<b>Manure Management Methane Emission Factors By Temperature For Poultry (KG CH<sub>4</sub> HEAD<sup>-1</sup> YR<sup>-1</sup>) (see Table 10.15, Volume 4, 2006 IPCC)</b>				
Poultry in Developing countries	CH <sub>4</sub> emission factor by average annual temperature (°C)			
	Cool (<15°C)	Temperate (15 to 25°C)	Warm (>25°C)	
	0.01	0.02	0.02	
<b>Mcf Values By Temperature For Manure Management Systems (see Table 10.17, Volume 4, 2006 IPCC)</b>				
System	MCFs by average annual temperature (°C)			Source and comments
	Cool	Temperate	Warm	
	≤ 10 to 14	15 to 25	26 to ≥ 28	
Poultry manure with litter	1.5%	1.5%	1.5%	Judgement of IPCC Expert Group. MCFs are similar to solid storage but with generally constant warm temperatures
Poultry manure without litter	1.5%	1.5%	1.5%	Judgement of IPCC Expert Group. MCFs are similar to dry lot at a warm climate.
<b>Definitions Of Manure Management Systems (see Table 10.18, Volume 4, 2006 IPCC)</b>				
System	Definition			
Poultry manure with litter	Similar to cattle and swine deep bedding except usually not combined with a dry lot or pasture. Typically used for all poultry breeder flocks and for the production of meat type chickens (broilers) and other fowl.			
Poultry manure without litter	May be similar to open pits in enclosed animal confinement facilities or may be designed and operated to dry the manure as it accumulates. The latter is known as a high-rise manure management system and is a form of passive windrow composting when designed and operated properly.			
<b>Default Values For Nitrogen Excretion Rate (Kg N (1000 Kg Animal Mass)<sup>-1</sup> Day<sup>-1</sup>) (see Table 10.19, Volume 4, 2006 IPCC)</b>				
<b>Poultry</b>	Region - Africa			
Hens >= 1 yr	0,82			
Pullets	0,6			
Other Chickens	0,82			
Broilers	1,1			
Turkeys	0,74			
Ducks	0,83			
<b>Default Emission Factors For Direct N<sub>2</sub>O Emissions From Manure Management (see Table 10.21, Volume 4, 2006 IPCC)</b>				
System	EF3 [kg N <sub>2</sub> O-N (kg Nitrogen excreted) <sup>-1</sup> ]			
Poultry manure with litter	0.001			
Poultry manure without litter	0.001			





 Find us:  
Department-of-  
Environment-Affairs

 Follow us:  
@EnvironmentZA

 Follow us:  
@EnvironmentZA

 Watch us:  
EnvironmentZA

**For more information please visit:**  
**[www.environment.gov.za](http://www.environment.gov.za) | Call Centre: 086 111 2468**